



**City Council Agenda**

Monday, May 4, 2026

Closed Session – 6:00 p.m.

Regular Session – 7:00 p.m.

Room 102

---

**CALL TO ORDER**

**CLOSED SESSION**

PENDING LITIGATION

ACQUISITION OF PROPERTY

PERSONNEL

**REGULAR SESSION**

**RECOGNITION**

**PUBLIC COMMENT**

(matters not on the agenda)

**MAYORAL ANNOUNCEMENTS/COMMENTS**

**ALDERMEN ANNOUNCEMENTS/COMMENTS**

**CITY CLERK ANNOUNCEMENTS/COMMENTS**

**MANAGER'S REPORT**

**CITY ATTORNEY/GENERAL COUNSEL REPORT**

**REPORT OUT OF CLOSED SESSION – RESOLUTION R-126-26:** Consideration of a Resolution Approving and Authorizing the Execution of a Settlement Agreement Between the City of Des Plaines, the Chicago District Camp Ground Association, and Chicago District Camp Ground, Inc.

**CONSENT AGENDA**

1. **RESOLUTION R-119-26:** Awarding the Bid for the 2026 Fiberized Asphalt Crack Sealing Program to Denler, Inc., Joliet, Illinois Per Unit Prices Submitted in the Not-to-Exceed Amount of \$100,000. Budgeted Funds – Motor Fuel Tax/Other Services.
2. **RESOLUTION R-120-26:** Approving LED Streetlight Upgrades to H&H Electric, Franklin Park, Illinois in the Amount of \$59,163.26. Budgeted Funds – Miscellaneous Contractual Services.
3. **RESOLUTION R-121-26:** Awarding the Bid for the 2026 Brick Paver Repairs to C.R. Schmidt, Inc., Warrenville, Illinois per Unit Prices Submitted in the Not-to-Exceed Amount of \$125,000. Budgeted Funds – Street Maintenance and Facilities and Grounds Maintenance.
4. **RESOLUTION R-122-26:** Approving a Grant Agreement from the Illinois Department of Commerce & Economic Opportunity for the 2026 Water Main Project in the amount of \$250,000.00
5. **RESOLUTION R-123-26:** Awarding the Bid for the 2026 Water Main Project to John Neri Construction, Inc. in the Amount of \$6,028,939.20. Budgeted Funds – Water/Sewer & Capital Projects.
6. **RESOLUTION R-124-26:** Approving Task Order #3 with M.E. Simpson Company, Inc., Valparaiso, Indiana in the Total Amount of \$91,000.00. Funding Source – Water Fund.
7. Minutes/Regular Meeting – April 20, 2026
8. **RESOLUTION R-127-26:** Authorizing Funding for Rights to Screen Motion Pictures at the Des Plaines Theatre
9. Minutes/Closed Session – April 20, 2026

**UNFINISHED BUSINESS**

n/a

**NEW BUSINESS**

1. MAYOR ANDREW GOCZKOWSKI – Discussion/Presentation on I-490 Tollway Project
2. FINANCE & ADMINISTRATION – Alderman Dick Sayad, Chair
  - a. Warrant Register in the Amount of \$3,963,686.85 – **RESOLUTION R-125-26**
3. COMMUNITY DEVELOPMENT – Alderman Colt Moylan, Chair
  - a. Consideration of a Resolution Approving the Purchase of the Property Located at 300 E. Northwest Highway, the former YMCA Building – **RESOLUTION R-115-26**

- b. Consideration of a Resolution Approving a Term Sheet for an Economic Development Agreement Regarding the Property at 300 E. Northwest Highway, the former YMCA Building – **RESOLUTION R-116-26**
- c. Consideration of an Ordinance Approving a Conditional Use for an Electronic Message Board (EMB) Sign and a Major Variation for Sign Area for ALM 7 LLC and DPM LLC at 999 E. Touhy Avenue – **ORDINANCE Z-8-26**
- d. Consideration of an Ordinance Approving a Conditional Use for a Commercial School for Central Scholar Academy at 1585 Ellinwood Street – **ORDINANCE Z-9-26**

**OTHER MAYOR/ALDERMEN COMMENTS FOR THE GOOD OF THE ORDER**

**ADJOURNMENT**

ORDINANCES ON THE AGENDA FOR FIRST READING APPROVAL MAY ALSO, AT THE COUNCIL'S DISCRETION, BE ADOPTED FOR FINAL PASSAGE AT THE SAME MEETING.

Persons with disabilities who require certain accommodations in order to observe or participate in a public meeting or have questions about the accessibility of the public meeting should contact the ADA Coordinator at least 48 hours (or two business days) in advance of the scheduled meeting. The ADA Coordinator can be reached in person at 1420 Miner St., Des Plaines, IL; by telephone at (847)391-5486; or by email at [hr@desplainesil.gov](mailto:hr@desplainesil.gov).

Notices of this meeting were posted in accordance with the requirements of 5 ILCS 120/1 et. Seq. (Open Meetings Act).



## CITY ATTORNEY

1420 Miner Street  
Des Plaines, IL 60016  
P: 847.391.5300  
desplainesil.gov

## MEMORANDUM

Date: April 28, 2026  
To: Mayor and Members of the City Council  
CC: Dorothy Wisniewski, City Manager  
From: Peter Friedman, City Attorney  
Subject: Campground Settlement Agreement

---

**Issue:** For the City Council to consider Resolution R-126-26 approving and authorizing the execution of a settlement agreement between the City of Des Plaines and the Chicago District Camp Ground Association and Chicago District Camp Ground, Inc.

**Analysis:** At its May 4, 2026 regular meeting, the Des Plaines City Council will consider adoption of Resolution No. R-126-26, approving and authorizing execution of a settlement agreement (“**Settlement Agreement**”) between the City and the Chicago District Camp Ground Association and Chicago District Camp Ground, Inc. (collectively, “**Camp Ground**”). The Settlement Agreement would terminate ongoing litigation between the City and the Camp Ground and resolve numerous public health and safety issues that exist at the Camp Ground property located at 1250 Camp Ground Road in Des Plaines (“**Property**”).

The resolution of the significant and long-standing property maintenance and flood regulation issues on the Property, and the termination of the extensive litigation associated with those issues, is of significant public interest, in part because of the direct positive impact that the resolution of these matters will have on Des Plaines property owners and the price many pay for flood insurance. The Council has directed us to prepare this memorandum and to make it available to the general public to ensure that the Council and the public have relevant background and a summary of the Settlement Agreement before the Council vote on approval of the Settlement Agreement.

**I. Background on Property and Flood Insurance Program**

The Campground Property consists of 26.4 acres along the Des Plaines River in the City. The Property is improved with dozens of structures, including cottages, two tabernacles, lodges, storage buildings, restroom facilities, and other buildings. Most of the structures on the Property were constructed around 1900 as part of a religiously affiliated campground.

As a “flood prone community” designated by FEMA, the City has participated in the National Flood Insurance Program (“**NFIP**”) for over 30 years. The City participates in the NFIP so that City property owners can purchase flood insurance and are eligible to receive FEMA disaster funding. To participate in the NFIP, the

City is required to adopt and enforce a floodplain management ordinance that meets or exceeds NFIP criteria (“**Floodplain Regulations**”). The Floodplain Regulations require, among other things, that all structures within the floodplain determined to be substantially damaged, as defined by the Floodplain Regulations, must be either elevated or demolished so as not to incur further flood damage and continue to cause repeated flood insurance claims.

Additionally, NFIP runs the Community Rating System (“**CRS**”), a program that recognizes communities for their floodplain management activities that exceed the NFIP minimum standards, reduce flood damage to insurable properties, and take a comprehensive approach to floodplain management. Under the CRS, participating communities are rated, and the ratings entitle owners of property within the community to discounts on flood insurance premiums.

To maintain participation in the NFIP and the CRS, the City must be recertified each year and attest that all credited floodplain management activities are being implemented. At least every five years, IDNR conducts a Community Assistance Visit to review each participating community’s compliance and code enforcement activities.

The Campground Property is located in the “regulatory floodway” as designated by FEMA and is subject to the Floodplain Regulations. Since 2017, IDNR identified the Property as the area in the City with the highest level of noncompliance with the Floodplain Regulations and has required the City to fulfill its obligations under the NFIP and CRS to enforce the Floodplain Regulations.

The impact of the City’s participation in the NFIP is significant. City property owners forced to obtain flood insurance outside the NFIP program would likely incur insurance cost increases of as much as 400 to 500 percent.

## **II. Summary of Litigation**

On April 9, 2021, the City filed a complaint against the Camp Ground in the Circuit Court of Cook County, Illinois, Case No. 2021 M2 001319, seeking relief pursuant to the Illinois Unsafe Property Statute, 65 ILCS 5/11-31-1, and the City of Des Plaines City Code, and alleging unsafe conditions and ongoing code violations, including violations of the Flood Control Regulations, at the Property, which case is currently pending (“**Unsafe Property Action**”). The Camp Ground filed eight separate counterclaims and affirmative defenses against the City (collectively, “**Counterclaims**”) (the Unsafe Property Action and Counterclaims are referred to in this memorandum as the “**Litigation**”).

The City was successful in having the Counterclaims dismissed, three with prejudice and five without prejudice. The only part of the Litigation that is presently pending before the Court is the City’s Complaint. The Court has continued the case over the last several months to provide the parties an opportunity to engage in mediation and attempt to reach a settlement. The Camp Ground has indicated that it would appeal or refile its counterclaims if the matter could not be amicably settled.

At the Council’s direction, the City Attorney and City Staff have undertaken extensive, time-consuming, and good faith negotiations with the Camp Ground resulting in the Settlement Agreement that the City Council will consider at its May 4 meeting.

## **III. Settlement Agreement**

The Settlement Agreement is attached to Resolution R-126-26. The following is a summary of the key terms and conditions of the Settlement Agreement (including the corresponding citations to the Agreement).

### **A. Property Subdivision (§1).** The Property will be subdivided into two new lots.

- Lot 1 (“**Camp Ground Parcel**”) will be located at the southeast corner of the Property

generally at the intersection of Joseph Schwab Road and East Algonquin Road. The Camp Ground Parcel will be approximately five acres. There are only five structures currently located on the Camp Ground Parcel.

- Lot 2 (“*City Parcel*”) will include all the remaining portions of the Property (about 80 percent of the total Property). The City Parcel will be approximately 22 acres. There are approximately 70 structures on the City Parcel. Virtually all of the City Parcel is located in the floodway.
- B. Property Disposition (§2.A).** The Camp Ground will convey the City Parcel to the City. The Camp Ground will retain ownership of the Camp Ground Parcel.
- C. Settlement Amount; Conditions (§§2.B-2.E).** The City will make a restricted settlement payment to the Camp Ground in the amount of \$4,000,000. The Settlement Agreement includes a number of conditions that must be met before the City is obligated to make this payment. The City will pay the Settlement Amount only as part of a closing on the conveyance to the City of the City Parcel, which closing is currently scheduled for October 31, 2026. Before the closing, the Camp Ground must ensure that the City Parcel is vacant and completely free from any occupants and that any right of any individual to possession, ownership, or control of any part of the City Parcel or any of the structures on the City Parcel has been terminated.
- D. Settlement Amount Restrictions (§4.A).** Use of the Settlement Amount is restricted. The Camp Ground may only use the funds for compliance with the Settlement Agreement and closing costs. After those costs are met, the Camp Ground may only use any remaining funds for reasonable expenses for the operation, use, maintenance, repairs, and improvements (capital and otherwise) of the Camp Ground Parcel and replacement of its improvements and other Camp Ground purposes on the Camp Ground Parcel. The Camp Ground is required to provide the City with a biannual written accounting describing receipts, expenditures, and remaining balance of the Settlement Amount.
- E. Structures on the City Parcel (§§2.F, 3.A, 4.B, 6).** With two limited exceptions, the Camp Ground has agreed that under the Settlement Agreement the City may demolish all the structures on the City Parcel without further action by the Court or the Camp Ground. The City may commence these demolitions at any time after the closing. The two exceptions are as follows:
- **Waldorf Tabernacle.** The City has agreed to relocate the Waldorf Tabernacle building at the City’s expense to an agreed location in the northern portion of the Camp Ground Parcel. The parties acknowledge that this relocation may require taking the building apart and reassembling it and may necessitate replacement of rotten, broken, or other unsalvageable elements. The City is only obligated to make the relocated building safe for exterior viewing, but not interior occupancy.
  - **Other Relocated Structures.** The Camp Ground may identify other structures on the City Parcel that it wants to relocate to the Camp Ground Parcel. The Camp Ground must identify these structures within 60 days after the date on which the Litigation is dismissed. The Camp Ground must move at its cost any of these identified structures within 90 days after the closing. The City may demolish any structures on the City Parcel that are not identified and moved according to these time restrictions. The Camp Ground must ensure that all structures that are moved from the City Parcel to the Camp Ground Parcel comply with the City Code, including the Waldorf Tabernacle, by an agreed upon schedule set forth in the Agreement.
- F. Future Use of the City Parcel (§3.B).** Once all the structures on the City Parcel are demolished or relocated, the City is required to maintain the City Parcel as open space and may not build new vertical structures or new paved parking lots on the City Parcel, except for limited improvements for safety, public use and enjoyment of the open space, or environmental restoration.
- G. Structures on Camp Ground Parcel (§4.C).** The Camp Ground must bring the structures already on the Camp Ground Parcel at the time of the Settlement Agreement into compliance with the City Code by an agreed upon schedule set forth in the Agreement.

- H. Camp Ground Parcel Code Compliance (§4.F).** The Camp Ground must maintain the Camp Ground Parcel in compliance with the City Code.
- I. Camp Ground Parcel Right of First Refusal (§4.G).** The Camp Ground will grant the City a right of first refusal if the Camp Ground ever desires to sell or otherwise convey or transfer all or any portion of the Camp Ground Parcel.
- J. Residence on Camp Ground Parcel (§4.E).** Only one structure on the Camp Ground Parcel may be used by the Camp Ground as a year-round residence.
- K. Parking (§5).** The City will allow the Camp Ground to use, on a nonexclusive basis, a parking lot on the City Parcel free of charge, including overnight parking for Camp Ground vehicles, subject to agreed identification methods and other City parking rules.
- L. History (§3.C).** The City will install up to two signs or plaques memorializing the history of the Property, including the Waldorf and Wesley Tabernacles.
- M. Permits (§3.D).** The City will diligently process Camp Ground permit applications and will not delay or deny permits for reasons outside City Code requirements.
- N. Dismissal (§10).** Promptly after approval of the Settlement Agreement, the City and the Camp Ground will take the necessary steps to have the Court enter an Agreed Order of Dismissal. This Order will provide that the Court will retain jurisdiction to enforce the terms and conditions of the Settlement Agreement.
- O. Mutual Releases (§11).** The Settlement Agreement includes mutual releases of claims related to the Litigation, except for claims based on breach of the Agreement itself and claims based solely on conduct occurring after the effective date of the Agreement.
- P. Enforcement (§13).** If either party breaches the Agreement, the non-breaching party may recover damages, costs, and attorneys fees, and the existing court case remains available for enforcement.
- Q. Warranty of Execution (§25).** Daniel Amarei has executed the Agreement as President of both the Chicago District Camp Ground Association and the Chicago District Camp Ground, Inc. Under the Agreement, the Camp Ground warrants that Mr. Amarei has the authority to act for and bind each of these two entities. Likewise, upon approval of Resolution R-126-26, the City Manager and City Clerk will be authorized to execute the Settlement Agreement on behalf of the City. Under the Settlement Agreement the City warrants that the City Manager and the City Clerk have the authority to act for and bind the City.

#### **IV. Settlement Agreement Benefits**

The Settlement Agreement achieves the City’s main objectives for the Litigation, provides additional benefits to the public, respects the historic nature of the Camp Ground Property, and allows for a sustainable, functional future for the Camp Ground. The anticipated benefits are summarized below:

- A. Potential Grants.** The Settlement Agreement allows the City to apply for grants from the Illinois Department of Natural Resources (IDNR) for the fair market value of the City Parcel and structure demolition costs. If awarded, the grant funds will partially offset the costs of the settlement.
- B. Flood Regulations.** The removal of all the structures from the floodway (via demolition of most of the structures and relocation of a select few) will resolve all the outstanding flood and property-maintenance-related City Code violations on the Property. This will bring the City into compliance with its obligations, imposed by FEMA and IDNR, to enforce the Flood Regulations and will allow Des Plaines property owners to remain in the National Flood Insurance Program at the current reduced rate. If the City had not resolved this issue, the estimated 1,800 residents could have had an overall annual policy increase of approximately \$10.5 million, or \$7,000 per household on an annual basis.
- C. Property Maintenance.** The demolition of most of the structures and the rehabilitation of the remaining structures resolves all the dangerous and hazardous conditions posed by the existing structures. It also abates current and future concerns from MWRD, including those related to septic tanks in the floodway.

- D. Open Space Benefits to the Public.** The City Parcel will provide additional benefit to the general public because it contains the entire river-front of the Property and has vehicular access from Camp Ground Road. City ownership of this portion of the Property creates the opportunity to connect the public green spaces to the north and south (Northwestern Woods and Camp Ground Road Woods).
- E. Camp Ground Parcel Benefits.** The Camp Ground will retain the Camp Ground Parcel, a compact, five-acre parcel that provides the Camp Ground the ability to remain on a portion of the historic property they value while being a much more manageable size. In the past, the Camp Ground has not had the funds to properly care for and maintain its Property. The funds the Camp Ground receives through the settlement may only be used for compliance with the Settlement Agreement, maintenance of the Camp Ground Parcel, and Camp Ground activities on the Camp Ground Parcel.
- F. Waldorf Tabernacle.** The historic Waldorf Tabernacle will be preserved and placed in a location that should be secure from future flooding and where the Camp Ground can continue to appreciate it.
- G. Limited Residential Use.** There will only be one continually occupied residential structure on the Camp Ground Parcel, which should resolve issues related to the residential occupancy on the Camp Ground Property, including occupants performing work on the structures without permits.
- H. Resolution of Litigation.** The settlement avoids what was likely to be further protracted and expensive litigation. Even if resolved in the City's favor, the litigation was unlikely to result in a similarly comprehensive, long-term solution to the property maintenance and flood regulation issues on the Property.
- I. City Code Compliance.** The Settlement Agreement clarifies that structures that remain on the Camp Ground Parcel will be required to comply with the City Code. The Agreement also states that the Camp Ground must maintain the Camp Ground Parcel in compliance with the City Code.

**Recommendation:** We recommend that the Council confirm that the Settlement Agreement is consistent with the Council's direction and thus adopt Resolution No. R-126-26, approving and authorizing execution of the Settlement Agreement between the City and the Chicago District Camp Ground Association and Chicago District Camp Ground, Inc.

***Attachments:***

**Resolution R-126-26**

**Exhibit A – Settlement Agreement and Mutual Release**

**CITY OF DES PLAINES**

**RESOLUTION R - 126 - 26**

**A RESOLUTION APPROVING AND AUTHORIZING THE EXECUTION OF A SETTLEMENT AGREEMENT BETWEEN THE CITY OF DES PLAINES AND THE CHICAGO DISTRICT CAMP GROUND ASSOCIATION AND CHICAGO DISTRICT CAMP GROUND, INC.**

**WHEREAS**, Article VII, Section 10 of the 1970 Illinois Constitution authorizes the City to contract with individuals, associations and corporations, in any manner not prohibited by law or ordinance; and

**WHEREAS**, the property commonly known as 1250 Camp Ground Road, Des Plaines, Illinois ("**Property**") is improved with dozens of structures, many of which are located in the regulatory floodway and are in disrepair; and

**WHEREAS**, Title 14 of the City of Des Plaines City Code ("**City Code**"), sets forth flood control regulations ("**Flood Control Regulations**") the City must enforce to remain compliant with the Federal Emergency Management Agency ("**FEMA**") National Flood Insurance Program ("**NFIP**"), which enables owners of property in the City, a designated flood-prone community, to obtain flood insurance at more affordable rates; and

**WHEREAS**, the City filed a complaint against both the Chicago District Camp Ground, Inc. and Chicago District Camp Ground Association (collectively, "**Camp Ground**") in the Circuit Court of Cook County, Illinois, Case No. 2021 M2 001319, seeking relief pursuant to the Illinois Unsafe Property Statute, 65 ILCS 5/11-31-1, and the City of Des Plaines City Code, concerning allegations of unsafe conditions and ongoing code violations, including violations of the Flood Control Regulations, at the Property, which case is currently pending ("**Unsafe Property Action**"); and

**WHEREAS**, the Camp Ground filed multiple counterclaims and affirmative defenses against the City (collectively, "**Counterclaims**") (collectively, the Unsafe Property Action and Counterclaims are the "**Litigation**"); and

**WHEREAS**, in order to (i) avoid the time, expense, and uncertainty of further litigation; (ii) resolve all Flood Control Regulations violations and ensure the City's continued participation in the NFIP; (iii) remove dangerous conditions from the Property; and (iv) allow the Camp Ground to continue to be present on a portion of the Property, the City and the Camp Ground desire to fully and finally settle the claims asserted in the Litigation, as well as all other actual and potential claims between and among the City and the Camp Ground arising out of or in any way related to the Litigation, pursuant to a settlement agreement ("**Settlement Agreement**"); and

**WHEREAS**, the Settlement Agreement generally provides, among other things, that in exchange for a restricted settlement payment by the City to the Camp Ground in the amount of \$4,000,000 after the Camp Ground satisfies numerous preconditions ("**Settlement Amount**"), the

Camp Ground will (i) subdivide the Property and convey to the City all but approximately five acres of the approximately 26-acre Property (“**City Parcel**”); (ii) agree that the City will demolish all of the buildings on the City Parcel other than a select few buildings that may be relocated to the portion of the Property to be retained by the Camp Ground (“**Camp Ground Parcel**”), including specifically the Waldorf Tabernacle Building; (iii) ensure that all buildings on the Camp Ground Parcel comply with the City Code; (iv) maintain the Camp Ground Parcel in compliance with the City Code; and (v) provide the City with a biannual written accounting describing receipts, expenditures, and remaining balance of the Settlement Amount; and

**WHEREAS**, the Camp Ground has warranted that it has properly approved and fully executed the Settlement Agreement; and

**WHEREAS**, the City Council has determined that it is in the best interest of the City to enter into the Settlement Agreement with the Camp Ground;

**NOW, THEREFORE, BE IT RESOLVED** by the City Council of the City of Des Plaines, Cook County, Illinois, in the exercise of its home rule powers, as follows:

**SECTION 1: RECITALS.** The above recitals are incorporated into, and made a part of, this Resolution as findings of the City Council.

**SECTION 2: APPROVAL OF SETTLEMENT AGREEMENT.** The City Council approves the Settlement Agreement in substantially the form attached to this Resolution as **Exhibit A**, and in a final form to be approved by the City Attorney.

**SECTION 3. AUTHORIZATION TO EXECUTE AGREEMENT.** The City Council authorizes and directs the City Manager and the City Clerk to execute and seal, on behalf of the City, the final Settlement Agreement.

**SECTION 4: EFFECTIVE DATE.** This Resolution shall be in full force and effect from and after its passage and approval according to law.

[SIGNATURES ON FOLLOWING PAGE]

**PASSED** this \_\_\_\_ day of \_\_\_\_\_, 2026.

**APPROVED** this \_\_\_\_ day of \_\_\_\_\_, 2026.

**VOTE:** AYES \_\_\_\_ NAYS \_\_\_\_ ABSENT \_\_\_\_

---

**MAYOR**

ATTEST:

Approved as to form:

---

**CITY CLERK**

---

**Peter M. Friedman, City Attorney**

Legal\Res\2017\DP-Resolution Approving Settlement Agreement with United States of America

#51670718\_v1

**SETTLEMENT AGREEMENT AND MUTUAL RELEASE**

This **Settlement Agreement and Mutual Release** (“*Agreement*”) is made and entered into this 14 day of April, 2026 (“*Effective Date*”) between and among the City of Des Plaines, an Illinois home rule municipal corporation (“*City*”); and Chicago District Camp Ground Association, an Illinois association created by State Charter (“*Association*”), and Chicago District Camp Ground, Inc., an Illinois not-for-profit corporation (“*Camp Ground Corporation*”) (collectively, the Association and the Camp Ground Corporation are the “*Camp Ground*”) (collectively, the City and the Camp Ground are the “*Parties*” and, individually, each a “*Party*”).

WHEREAS, the Camp Ground owns the property commonly known as 1250 Camp Ground Road, Des Plaines, Illinois, assigned property index number 09-21-106-009-0000, and legally described on **Exhibit A** to this Agreement (“*Property*”); and

WHEREAS, the Property is improved with numerous structures (“*Structures*”), private water and sewer mains (“*Underground Utilities*”), above-ground utilities (“*Aerial Utilities*”), and various paved and unpaved paths and roadways; and

WHEREAS, on April 9, 2021, the City filed a complaint against the Camp Ground Corporation in the Circuit Court of Cook County, Illinois, Case No. 2021 M2 001319, seeking relief pursuant to the Illinois Unsafe Property Statute, 65 ILCS 5/11-31-1, and the City Code of the City of Des Plaines, as amended from time-to-time (“*City Code*”), concerning allegations of unsafe conditions and ongoing code violations at the Property, which case is currently pending (“*Unsafe Property Action*”); and

WHEREAS, on December 16, 2021, the City filed a first amended complaint, adding the Association as a defendant in the Unsafe Property Action; and

WHEREAS, during the pendency of the Unsafe Property Action, the Camp Ground filed numerous counter-claims and affirmative defenses (collectively, the “*Counterclaims*”) (the Unsafe Property Action and Counterclaims are, collectively, the “*Dispute*”); and

WHEREAS, the Counterclaims have been dismissed; and

WHEREAS, the Camp Ground disputes any liability for the claims alleged in the Unsafe Property Action, and the City disputes any liability for the Counterclaims; and

WHEREAS, in order to avoid the time, expense, and uncertainty of further litigation, the Parties desire to fully and finally settle the claims asserted in the Dispute, as well as all other actual and potential claims between and among the Parties arising out of or in any way related to the Dispute, without the Parties thereby admitting any unlawful activity or liability to each other; and

**NOW, THEREFORE**, in consideration of these recitals and the mutual promises set forth in this Agreement, and for other good and valuable consideration stated in this Agreement, the adequacy of which is acknowledged, the Parties agree as follows:

## 1. Subdivision of the Property.

A. Subdivision. The Camp Ground agrees to subdivide the Property into two lots of record as depicted on **Exhibit B** to this Agreement ("**Subdivision**"), as follows: (i) a lot located at the south-east corner of the Property ("**Lot 1**"); and (ii) the remainder of the Property ("**Lot 2**").

B. Subdivision Plat Preparation and Approval. The City, at its own cost, will prepare the plat of subdivision for the Subdivision ("**Plat of Subdivision**"), which will include at the City's cost the preparation of an ALTA plat of survey and will facilitate the Camp Ground's application for the necessary approval from the City. The Plat of Subdivision shall be in the form required by the City's Subdivision Code ("**Subdivision Code**"), codified as Title 13 of the City Code, and with terms acceptable to the Parties, which acceptance will not be unreasonably withheld if the Plat of Subdivision conforms with the terms of this Agreement. The Camp Ground will be the "applicant" for the Plat of Subdivision approval and will cooperate with the approval process and with obtaining necessary signatures on the Plat of Subdivision once approved; provided, however, there will be no fees, costs or other expenses to the Camp Ground for the application and subdivision process. The City anticipates that the preparation and approval of the Plat of Subdivision will take approximately 100 days from the Effective Date. The Survey shall be certified to the City, the Camp Ground, and the Title Company and be in a form sufficient for the Title Company to issue its standard form commercial extended coverage and survey endorsements.

C. Additional Easements. The Parties will cooperate to include on the Plat of Subdivision access and other easements that are necessary to allow the Parties to access the Underground Utilities for maintenance purposes and to otherwise implement the provisions of this Agreement.

## 2. Conveyance of Lot 2.

A. Conveyance of Lot 2. The Camp Ground will convey to the City, and the City agrees to acquire from the Camp Ground, upon the terms and conditions set forth in this Agreement, fee simple title to Lot 2, together with (i) all privileges, rights, easements, hereditaments and appurtenances thereto belonging, (ii) all right, title and interest of the Camp Ground in and to any streets, alleys, passages and other rights of way included therein, and (iii) any improvements located upon Lot 2. This conveyance does not include the structure of the Waldorf Tabernacle as otherwise subject to the terms of this Agreement.

B. Settlement Amount. In consideration for the acquisition of Lot 2 and for the other terms, conditions, and obligations of this Agreement, the City will pay \$4,000,000.00 ("**Settlement Amount**") to the Camp Ground Association. The Settlement Amount will be paid by the City to the Camp Ground Association on the Closing Date (as defined in Section 2.C of this Agreement), by wire transfer or other immediately available funds. Transfer taxes and any outstanding City bills or other City Fees or charges, if applicable, shall be paid at Closing by the City.

C. Closing.

(i) The Campground must convey fee simple title to Lot 2 to the City by delivery of a Special Warranty Deed (“*Deed*”) in a form agreeable to the Parties. The Camp Ground must deliver full and complete possession of Lot 2 to the City upon Closing. The Camp Ground must deliver Lot 2 to the City in its condition as of the Dismissal Order (as defined in Section 10 of this Agreement) except for ordinary wear and tear.

(ii) Closing Time, Place. The Closing will occur on October 31, 2026, unless an earlier date is agreed to in writing by the Parties (“*Closing Date*”). The Closing will be at the office of Chicago Title Insurance Company (“*Title Company*”) located at 325 W. Wacker Drive, 11<sup>th</sup> Floor, Chicago, Illinois, 60601. The Parties need not physically attend the Closing. Any Title Company Closing Escrow fees and transfer taxes, if applicable, shall be paid by the City.

(iii) Closing Deliverables. At Closing, the Parties must have: (a) evidence reasonably satisfactory to the Title Company of the authority of the Camp Ground and City to consummate the Closing; (b) the Deed and other instruments of transfer and conveyance transferring Lot 2; (c) the recorded Plat of Subdivision; and (d) the fully executed Right of First Refusal Agreement, as set forth in Section 4 of this Agreement.

D. Conditions Precedent to Closing.

(i) Recordation of the Plat of Subdivision;

(ii) Full execution of the Right of First Refusal Agreement;

(iii) Full execution of the Parking Easement Agreement, as set forth in Section 5 of this Agreement;

(iii) Lot 2 must be vacant and completely free from any occupants on or before the Closing Date, as set forth in Section 4.D of this Agreement; and

(iv) Any right of any individual to possession, ownership, or control of any part of Lot 2 or any of the structures located on Lot 2 shall have been terminated on or before October 31, 2026, as set forth in Section 4.D of this Agreement.

E. Termination. If the Conditions Precedent to Closing, set forth in Section 2.D of this Agreement, have not been completed on or before the Closing Date, or any extension thereof agreed to in writing by both Parties, the City may terminate this Agreement by providing written notice to the Camp Ground.

F. The Parties acknowledge that the City intends to demolish all of the structures on Lot 2 except for the Waldorf Tabernacle and any structures actually moved to Lot 1 pursuant to the terms of this Agreement; the Camp Ground agrees not to object to the demolitions.

**3. City Obligations.**

**A. Relocation of the Waldorf Tabernacle.**

(i) Subject to the Uncontrollable Circumstances provisions set forth in Section 28 of this Agreement, the City shall relocate, at its sole expense in a good workmanlike manner and in accordance with all applicable laws, codes and ordinances, the structure identified as the Waldorf Tabernacle on Exhibit B from Lot 2 to the designated location on Lot 1. The specific location on Lot 1 will be designated by the Camp Ground in consultation with the City, provided that the location must (a) not be within the regulatory floodway; (b) be in the general location identified on Exhibit B; (c) be physically feasible and will not meaningfully increase the scope or cost of the relocation and reconstruction; and (d) comply with the City Code, including, without limitation, the flood control regulations set forth in Title 14 of the City Code.

(ii) The Parties understand, agree, and anticipate that the relocation of the Waldorf Tabernacle might require it to be taken apart and reassembled and might also require the replacement of rotten, broken, or other unsalvageable elements. The City will make commercially reasonable efforts to replace rotten, broken, or other unsalvageable elements with elements that are in a substantially similar location and are of a substantially similar appearance and material. The City will consult with an expert consultant regarding the relocation and will provide the Camp Ground with (i) an initial relocation schedule before work begins; (ii) one mid-project written status update; and (iii) a final relocation report or certificate from the relocation contractor summarizing work performed. The Waldorf Tabernacle will be placed upon a new foundation constructed by the City in the type and manner, including, without limitation, piers, determined by the City, in accordance with the City Code and in consultation with the expert consultant.

(iii) After relocation, the Waldorf Tabernacle will be in a condition that is safe to be viewed from the outside, but the City will not be required to place it in a condition safe for occupancy.

(iv) The City shall complete the relocation of the Waldorf Tabernacle in accordance with this Agreement within 12 months after the Closing Date.

(v) After the relocation of the Waldorf Tabernacle by the City, the Camp Ground may, at its own expense, undertake the construction or renovation work necessary to make the Waldorf Tabernacle safe for interior occupancy, provided such work is conducted in accordance with the City Code and pursuant to a building permit, if required.

**B. Lot 2 to Remain Undeveloped.**

(i) The obligations set forth in Section 3.B(ii) below will be recorded against Lot 2 as a deed restriction, permanent covenant, or similar recorded document. The Parties acknowledge that if the City receives grant funds, the funding entity might have

specific requirements for the form and substance of the restriction, and the Parties agree to use the required form as long it conforms generally with the terms of this Agreement and substantially satisfies the obligations of Section 3.B(ii).

(ii) Once all of the structures on Lot 2 are demolished or relocated, the City will maintain Lot 2 as open space, meaning the City, or any subsequent landowner or occupant, will not be permitted to construct additional paved parking lots, other than parking lots already existing on Lot 2, or new vertical construction, except for minimal improvements reasonably necessary for public safety, public use and enjoyment of the open space, environmental restoration, or as otherwise allowed by the deed restriction required by the grant funding entity.

C. Memorialization of Property History. The City, at its sole cost, will install up to two signs or plaques on Lot 2 memorializing the history of the Property and specifically memorializing the Waldorf Tabernacle and the Wesley Tabernacle. The City and Camp Ground will collaborate on the form, substance, and location of the signs or plaques, provided that the City will reasonably and acting in good faith make the final determination regarding the form, substance, and location.

D. City's Obligation Regarding Permits to Camp Ground. The City will diligently process the Camp Ground's permit applications and will not condition or delay permits, or refuse to issue permits, based on any reason other than the requirements for issuance of any requested permit under the City Code.

#### 4. Camp Ground Obligations.

##### A. Restricted Use of Settlement Amount.

(i) The Camp Ground may only use the Settlement Amount first towards the performance and compliance with this Agreement, payment of all of its costs and expenses of the Closing including its attorneys fees, and then exclusively for all reasonable expenses for the operation, use, maintenance, repairs, and improvements (capital and otherwise) of Lot 1 and replacement of its improvements and other Camp Ground purposes on Lot 1.

(ii) The Camp Ground shall provide the City with bi-annual written accounting of the Settlement Amount due to the City by January 31 and July 31 of each calendar year, describing receipts, expenditures, and remaining balance of the Settlement Amount. The first accounting shall be due to the City by July 31, 2027 for the period between the Closing Date and June 30, 2027. The City may request additional reasonable supporting documentation or information not more than once per calendar year solely for the purpose of clarifying information provided in that year's annual accountings. Upon exhaustion or depletion of the Settlement Amount, the Camp Ground shall provide a final accounting with 30 days' written notice stating that the Settlement Amount has been fully depleted or exhausted. Upon issuance of the final notice and accounting (and subject to the City's right to request additional reasonable supporting documentation or information as provided above),

the Camp Ground shall no longer be obligated to provide annual accountings as required by this Section.

B. Relocation of Structures by the Camp Ground. The Camp Ground may relocate specific structures from Lot 2 to Lot 1 as follows:

(i) The Camp Ground must identify which structures it wants to relocate (“*Identified Structures*”) and notify the City of the specific Identified Structures within 60 days after the date on which the Dismissal Order is entered. The Waldorf Tabernacle is not an Identified Structure as it will be relocated by the City.

(ii) The Identified Structures may be moved either to Lot 1 or to one or more alternative locations located outside of the Property selected by the Camp Ground. To the extent the Identified Structures are to be relocated to Lot 1, the Identified Structures must be relocated to locations that are outside of the regulatory floodway and that comply with the City Code, including, without limitation, the flood control regulations set forth in Title 14 of the City Code. The Campground may also relocate any Identified Structures to locations outside of the Property in accordance with all applicable law.

(iii) The Camp Ground shall relocate the Identified Structures, if any, at its sole cost, including the use of the Settlement Amount.

(iv) Subject to the Uncontrollable Circumstances provisions set forth in Section 28 of this Agreement, the Identified Structures, if any, must be moved within 90 days after the Closing Date (“*Move Deadline*”). The Camp Ground will have no right to move any Identified Structure after the Move Deadline or any requisite extension per the terms of this Agreement. After any Identified Structures are relocated from Lot 2, the City will, at no cost to or additional consideration from the Campground, execute a bill of sale transferring ownership of the relocated Identified Structure(s) to the Camp Ground. The City may demolish, without further action, order of court, or notice to the Camp Ground, any Identified Structure that has not been relocated from Lot 2 prior to the final Move Deadline.

(v) **Compliance of Structures Relocated to Lot 1:** The Camp Ground agrees to the following:

(1) Subject to the Uncontrollable Circumstances provisions set forth in Section 28 of this Agreement, any Identified Structure relocated from Lot 2 to Lot 1 pursuant to this Section 4.B (“*Moved Structures*”) must be brought into compliance with the City Code within one year after the date of the completed relocation (“*Compliance Deadline*”).

(2) Compliance of the Moved Structures with the City Code will be determined by the City building inspector pursuant to a full interior and exterior inspection of the Moved Structures. The City inspector will operate

on an independent basis with no bias related to the proceedings resulting in this Settlement Agreement.

(3) If, for any reason, the Camp Ground reasonably believes the inspection or resulting report by the City inspector includes determinations that are inconsistent with the City Code or rules adopted pursuant to the City Code, are based on incorrect interpretations of provision(s) of the City Code, or applies provision(s) that do not apply, the Camp Ground may appeal the determination of the City inspector in accordance with Section 12-3-9 of the City Code for provisions set forth in Title 12 (Zoning) of the City Code and in accordance with Section 10-14-2 of the City Code for provisions set forth in Titles 10 (Construction Regulations) and 14 (Flood Control Regulations) of the City Code.

(4) Upon the written final determination identifying specified items of non-compliance with the City Code, either in the form of a notice from the City inspector (if uncontested), or a written decision on appeal per Section 4.B.v.(3) of this Agreement, the Camp Ground will be provided 60 days, or as otherwise agreed to in writing between the Parties if compliance cannot be reasonably achieved within 60 days, to bring the Moved Structures into compliance with the deficiencies as indicated in the final determination.

(5) If the Moved Structures have not been brought into compliance with the City Code in accordance with this Agreement by the Compliance Deadline or any cure period provided pursuant to Subsection 4.B.v(4) of this Agreement, the City may petition the Court to enforce this provision and seek remedies, including, without limitation, demolition of any Moved Structures that are not brought into compliance by the Compliance Deadline, for which reimbursement for the costs of any such demolition, attorneys fees, and other costs shall be paid from the Settlement Amount or other funds available to the Camp Ground.

C. Rehabilitation of Existing Structures on Lot 1 by Camp Ground. Subject to the Uncontrollable Circumstances provisions set forth in Section 28 of this Agreement, the structures already located on Lot 1 and identified on Exhibit B ("**Marked Lot 1 Structures**") must be brought into compliance with the City Code on or before the Compliance Deadline. The compliance obligations for any Marked Lot 1 Structure are subject to the same inspection and conflict resolution provisions as specified in Section 4.B(v)(1)-(5) of this Agreement, and those provisions are incorporated in this paragraph by reference.

D. Existing Occupants on Lot 2.

(i) On or before October 31, 2026, the Camp Ground must take any and all necessary action to terminate any and all rights claimed by any person to possession, ownership, or control of any structure on Lot 2 or other claims to a legal right in the Property, and cause all persons occupying any structure on Lot 2 to

relocate, so that Lot 2 is vacant and without any occupants, leases, licenses, or other person asserting a claim or right to own or occupy any part of Lot 2 or the structures on Lot 2. The Camp Ground is responsible for any costs or expenses incurred in fulfilling its obligations set forth in this Section.

(ii) The Camp Ground must notify the City in writing at least 30 days before October 31, 2026, if it will not have completed its obligations set forth in Section 4.D(i) by October 31, 2026. Such notice must provide a summary of all measures taken by the Camp Ground to comply with Section 4.D(i), which structures remain occupied, and the date on which the Camp Ground anticipates it will have complied with Section 4.D(i). Upon receipt of such notice that demonstrates the Camp Ground has diligently worked to comply with Section 4.D(i), the City will agree to a reasonable cure period, not to exceed 120 days, for the purpose of providing additional time to the Camp Ground to comply with Section 4.D(i). In the absence of such notice, the City may conduct a pre-closing walk-through inspection of Lot 2 during the seven-day period before the Closing Date with sufficient access to confirm compliance with Section 4.D(i). If the Camp Ground does not comply with Section 4.D(i) by the Closing Date, or any extended deadline agreed to in accordance with this Section 4.D(ii), the City may terminate this Agreement by providing written notice to the Camp Ground in accordance with Section 2.E of this Agreement.

E. Residential Occupancy on Lot 1. Only one structure located on Lot 1 may be occupied as a year-round residence. The Camp Ground will notify the City as to which structure will be used as a year-round residence upon initial occupancy and will promptly notify the City if a different structure will be used for this purpose in the future.

F. Maintenance of Lot 1. The Camp Ground will maintain Lot 1 in compliance with the City Code.

G. Right of First Refusal Agreement. Immediately after Closing, the Camp Ground will record a right of first refusal agreement (“*Right of First Refusal*”) against Lot 1 pursuant to which the Camp Ground must provide notice to the City if, at any time, the Camp Ground desires to sell or otherwise convey, receives an offer to purchase, or otherwise acquire, Lot 1, or any portion thereof. The Right of First Refusal Agreement will grant the City the right to match the terms of the offer and enter into a contract (no later than 45 days after the notice) with the Camp Ground for the purchase and acquisition of Lot 1 or the portion thereof.

5. Camp Ground Vehicle Parking on Lot 2. The City will allow the Camp Ground to use, free of any charge or cost, the parking lot located on Lot 2 in the general location depicted on Exhibit B for its employees, residents, agents, and invitees (“*Camp Ground Vehicles*”), provided that the parking lot might also be open to and shared with the general public. The City does not allow overnight public parking in City-owned parking lots but will allow Camp Ground Vehicles to park overnight, subject to the conditions and restrictions of this Agreement. The City and the Camp Ground will mutually agree on a method for distinguishing Camp Ground related vehicles from vehicles belonging to the general public so that the City can avoid ticketing Camp Ground Vehicles that park overnight. Except for the overnight parking prohibition, Camp Ground

Vehicles will comply with all other applicable parking regulations set forth in the City Code when parked on Lot 2. A parking easement agreement containing customary terms and conditions necessary to memorialize the agreement set forth in this Section 5 shall be recorded by the City at Closing providing for this parking right.

**6. Demolition of Structures on Lot 2.** After the Closing Date, the City may demolish any of the structures on Lot 2 except for the Waldorf Tabernacle and any Identified Structures pursuant to and subject to the conditions set forth in Section 4.B of this Agreement, including the City's right to demolish any Identified Structures that do not comply with the City Code by the Compliance Deadline pursuant to the terms of this Agreement.

**7. Underground Utilities and Aerial Utilities.**

A. Underground Utilities. After the Closing Date and after the structures on Lot 2 have been either demolished or relocated, the City may, but is not obligated to, perform work on the Underground Utilities to reduce their scope on Lot 2 as they will no longer be necessary to serve any structures on Lot 2 ("*Underground Utility Work*"), including, without limitation, abandoning disconnected sections in place. The Underground Utility Work shall not reduce or negatively affect access to the service provided by the Underground Utilities to Lot 1 or to the Camp Ground.

B. Aerial Utilities. After the structures on Lot 2 have been either demolished or relocated, the Camp Ground and the City will cooperate on the removal of the Aerial Utilities from Lot 2 and the reconfiguration of those Aerial Utilities as necessary to maintain service to Lot 1 and the Camp Ground.

**8. Temporary Licenses.**

A. The Camp Ground hereby grants the City a temporary license to, upon reasonable advanced notice to the Contact Person listed below, access Lot 1 for the purpose of (a) performing surveying, appraisal, or other due diligence activities reasonably required to timely comply with this Agreement; (b) relocating the Waldorf Tabernacle as set forth in Section 3.A of this Agreement; and (c) performing the Underground Utility Work as set forth in Section 7 of this Agreement. The City will provide evidence of insurance sufficient to protect the City that identifies the Camp Ground as additional insured for any work performed pursuant to the temporary license, and require any contractor or subcontractor to provide proof of all necessary insurance that names the Camp Ground as an additional insured. The City will provide proof of insurance for itself in advance of entering on to the Property pursuant to this notice to perform any work, and will require any contractor or subcontractor to provide sufficient evidence of insurance, including, but not limited to, certificates of insurance, that identify or name the Camp Ground as an additional insured or provide coverage to the Camp Ground for any work performed for which the license will be used.

B. After Closing, the City will grant a temporary license to the Camp Ground to allow the Camp Ground access, upon reasonable notice to the City's Contact Person listed below, to Lot 2 for the purposes of relocating structures to Lot 1 as set forth in Section 4.B of this Agreement. The Camp Ground will provide evidence of insurance sufficient to

protect the Camp Ground that identifies the City as additional insured for any work performed pursuant to the temporary license, and require any contractor or subcontractor to provide proof of all necessary insurance that names the City as an additional insured. The Camp Ground will provide proof of insurance for itself in advance of entering on to Lot 2 pursuant to this notice to perform any work, and will require any contractor or subcontractor to provide sufficient evidence of insurance, including, but not limited to, certificates of insurance, that identify or name the City as an additional insured or provide coverage to the City for any work performed for which the license will be used.

9. **Reasonable Cooperation.** The Parties understand and agree that each of the provisions of this Agreement may necessarily require some element of bureaucratic or logistical cooperation by both Parties, even when the obligations of a particular provision are fully assigned to one Party in particular. The Parties agree to reasonably cooperate with each other's reasonable bureaucratic or logistical requests as reasonably necessary to fulfill all of the obligations set forth in this Agreement.

10. **Dismissal Order.** The Parties will enter an agreed dismissal order in the form provided in **Exhibit C** to this Agreement dismissing the Dispute with prejudice ("**Dismissal Order**"), with each party bearing its own costs and fees, and the court retaining jurisdiction for the purpose of enforcing the terms of this Agreement. Each Party will execute the Dismissal Order in the spaces provided. The Parties will cooperate to prepare and file the Dismissal Order and to ensure the entry of the Dismissal Order by the Court.

11. **Release.** Conditioned on compliance with the provisions of this Agreement, each Party, for and on behalf of itself and its heirs, executors, personal representatives, agents, successors and assigns, and elected and appointed officials, employees, and attorneys, acknowledges full and complete satisfaction of, and fully and forever releases, acquits, and discharges each other Party and their respective heirs, executors, officers, directors, employees, personal representatives, agents, attorneys, successors and assigns, including, without limitation, all present and former City elected officials and any other City officials, in their individual and official capacities, and all present and former individual board members of the Camp Ground Association and Corporation in their individual and corporate capacities (collectively, the "**Releasees**") from any and all claims, causes of action, demands, liabilities, damages, obligations, and debts (collectively referred to as "**Claims**"), of every kind and nature, whether known or unknown, suspected or unsuspected, or fixed or contingent, which any Party holds or at any time previously held against any other Party, or any of the Releasees, arising out of or in any way related to the claims asserted in the Dispute (with the exception of breaches of this Agreement), or under any other statute, rule or common law provision, including any claim for civil penalties arising from the facts alleged in the Dispute, through the Effective Date of this Agreement. The mutual release provided in this Section shall be effective and conditioned upon (i) the Effective Date of this Agreement, (ii) the entry of the Dismissal Order, and (iii) compliance with the terms and conditions of this Agreement. For the avoidance of doubt, save for claims regarding breach of this Agreement, neither Party releases any claims based solely on conduct or events subsequent to the Effective Date of this Agreement, including, without limitation, constitutional claims, statutory claims, or allegedly unsafe conditions or City Code violations at the Property that did not exist on or prior to the Effective Date and solely arose after the Effective Date.

12. **No Admission of Liability.** Nothing in this Agreement will be construed as an admission of liability on the part of any of the Parties, their respective Releasees, or any of them, such liability having been expressly denied. No inducements or representations have been made by any agent or attorney of any Party released under this Agreement as to the legal liability or other responsibility of any Party claimed responsible.

13. **Breach of Agreement.** The Parties understand and agree that if any of them is found by a court of law to have breached any provision of this Agreement, including the court before whom the Dispute has been assigned and which retains jurisdiction to enforce the terms of this Agreement, including, without limitation, Section 2.E of this Agreement, so that neither Party will have to file a new complaint in such circumstances, then the breaching Party shall be liable to the other Party for all damages caused by the breach, including, but not limited to, all costs and attorney's fees incurred by said parties in enforcing their rights hereunder.

14. **Severability.** The provisions of this Agreement are fully severable. If any provision of this Agreement is determined to be invalid or unenforceable for any reason, that invalidity or unenforceability will not affect the validity or enforceability of any of the other provisions of the Agreement.

15. **Entire Agreement; Modification.** This Agreement constitutes the sole and entire agreement between the Parties with respect to the subject matter of this Agreement; supersedes any and all prior or contemporaneous agreements, discussions or representations, oral or written, including, without limitation, the ADR Commercial Mediation Settlement Agreement term sheet, with respect to that subject matter; and cannot be amended except in a writing which specifically refers to this Agreement and is signed by each of the Parties.

16. **Successors and Assigns.** This Agreement is binding upon, and inures to the benefit of, each of the Parties and their respective heirs, executors, personal representatives, successors, and assigns.

17. **No Effect on Third Parties.** The terms and conditions, covenants, agreements, powers, privileges, and notices of authorization contained in this Agreement are binding upon and inure only to the benefit of the Parties and their respective successors, affiliates, assigns, heirs, agents, and attorneys including, without limitation, any of the Releasees. Only the Parties are authorized to rely upon the contents of this Agreement or are deemed a beneficiary of this Agreement.

18. **Governing Law and Jurisdiction.** The Second Municipal Division of the Circuit Court of Cook County will retain jurisdiction over the Dispute for the purpose of enforcing the provisions of this Agreement. This Agreement and any amendments to this Agreement will be governed by, and construed in accordance with, the laws of the State of Illinois, without regard to conflict of law principles.

19. **Non-Waiver.** The failure of any Party to this Agreement to exercise or enforce any provision of this Agreement on one or more occasions will not be deemed a waiver of that provision, nor will a waiver of any provision on one occasion affect a Party's right to enforce that provision fully on other occasions. Any waiver must be in writing and signed by the Party waiving its right in order to be valid and enforceable.

**20. Representation by Counsel and Drafting.** Each of the Parties acknowledges that it has either been represented by or had access to competent legal counsel of its own choosing both in connection with the Dispute and in connection with the negotiations, drafting, and execution of this Agreement. Accordingly, the language used in this Agreement will be deemed to be language chosen by all Parties to express their mutual intent, and no rule of strict construction against any Party will apply to any term or condition of this Agreement.

**21. Lot 2, Structures, Utilities, Appurtenances Conveyed As Is.** Except for the covenants, obligations, representations and warranties of the Camp Ground expressly set forth in this Agreement, the City specifically acknowledges and agrees that the Camp Ground is conveying and the City is receiving Lot 2, and the structures and all other improvements and appurtenances on Lot 2, on an “as is with all faults” basis and that the City is not relying on any other representations or warranties of any kind whatsoever, express or implied, from the Camp Ground, or its agents, attorneys or any other person acting or purporting to act on behalf of Camp Ground, as to any matters concerning Lot 2, including without limitation: (i) the quality, nature, adequacy and physical condition and aspects of Lot 2, including, but not limited to, the structural elements, seismic aspects of Lot 2, structures, foundations, roofs, appurtenances, access, landscaping, parking facilities and the electrical, mechanical, HVAC, plumbing, sewage, and utility systems, facilities and appliances, the square footage within the improvements on Lot 2; (ii) the quality, nature, adequacy, and physical condition of soils, geology and any groundwater on Lot 2; (iii) the existence, quality, nature, adequacy and physical condition of utilities serving Lot 2; (iv) the development potential of Lot 2, and Lot 2’s use, habitability, merchantability, or fitness, suitability, value or adequacy of Lot 2 for any particular purpose; (v) the zoning or other legal status of Lot 2 or any other public or private restrictions on use of Lot 2; (vi) the compliance of Lot 2 or its operation with any applicable codes, laws, regulations, statutes, ordinances, covenants, conditions and restrictions of any governmental or quasi-governmental entity or of any other person or entity or the compliance of Lot 2 with Environmental Laws; (vii) the presence of Hazardous Substances on, under or about Lot 2 or the adjoining or neighboring property; (viii) the quality of any labor and materials used in any improvements on Lot 2; (ix) the value, economics of the operation or income potential of Lot 2; or (x) any other fact or condition which may affect Lot 2, including, without limitation, the physical condition, value, economics of operation or income potential of Lot 2.

**22. Notices and Contacts.** Any notice required to be given under this Agreement must be in writing and must be delivered (i) personally; (ii) by a reputable overnight courier; (iii) by certified mail, return receipt requested, and deposited in the U.S. Mail, postage prepaid; or (iv) by E-mail. E-mail notices will be deemed valid and received by the addressee only upon explicit or implicit acknowledgment of receipt by the addressee. Unless otherwise expressly provided in this Agreement, notices will be deemed received upon the earlier of (a) actual receipt; (b) one business day after deposit with an overnight courier as evidenced by a receipt of deposit; or (c) three business days following deposit in the U.S. mail, as evidenced by a return receipt. By notice complying with the requirements of this Section, each party will have the right to change the address or the addressee, or both, for all future notices to the other Party, but no notice of a change of addressee or address will be effective until actually received.

City Draft 3/20/26

Additionally, the individuals noted as “Designated Contact” below will be the designated contact person for each Party that should be contacted regarding the subject matter of this Agreement.

Notices to the City will be addressed to, and delivered at, the following address:

City of Des Plaines  
1420 Miner Street  
Des Plaines, Illinois 60018  
Attention: City Manager  
E-mail: [dwisniewski@desplainesil.gov](mailto:dwisniewski@desplainesil.gov)

With a copy to:

Elrod Friedman LLP  
City Attorney  
350 N. Clark Street, 2<sup>nd</sup> Floor  
Chicago, Illinois 60654  
Attention: Peter M. Friedman  
E-mail: [peter.friedman@elrodfriedman.com](mailto:peter.friedman@elrodfriedman.com)

The City designated contact person is:

Designated Contact Person: Tim Watkins, Public Works Director  
E-mail: [twatkins@desplainesil.gov](mailto:twatkins@desplainesil.gov)  
Phone: (847)391-5468

Notices to the Camp Ground will be addressed to, and delivered at, the following address:

Chicago District Camp Ground  
1250 Camp Ground Road  
Des Plaines, Illinois 60016 \_\_\_\_\_  
Attention: Daniel Amarei  
E-mail: [damarei1@gmail.com](mailto:damarei1@gmail.com)

With a copy to:

MacDonald, Lee & Senechalle, Ltd.  
Attorney for Chicago District Camp Ground Association  
2300 Barrington Road, Suite 220  
Hoffman Estates, Illinois 60169  
Attention: R. Andrew Smith  
E-mail: [andrewsmith@pmllegal.com](mailto:andrewsmith@pmllegal.com)

The Camp Ground designated contact person is:

Designated Contact Person: Daniel Amarei  
E-mail: damarei1@gmail.com  
Phone: 773-968-3551

**23. Counterparts.** This Agreement may be executed in any number of counterparts, each of which will be deemed to be an original, and all of which, taken together, will constitute a single instrument.

**24. Captions.** The section headings in the Agreement are for convenience and reference only and will not in any way affect the meaning or interpretation of the Agreement.

**25. Warranty of Authority.** Each Party executing this Agreement warrants to the other that it has the authority to act for and bind the Party or Parties for which it executes this Agreement.

**26. Free and Voluntary Acts.** Each Party enters into this Agreement as a free and voluntary act, with full knowledge of its legal consequences. No Party has relied on any information or representations that are not set forth in this Agreement.

**27. Satisfactory Documentation.** The Parties will execute any other documents and take any other action as may be reasonably necessary to further the purposes of this Agreement.

**28. Uncontrollable Circumstances.**

A. For the purposes of this Agreement, “*Uncontrollable Circumstance*” means any of the following events and circumstances that are unavoidable or that the Party could not prevent or overcome through reasonable efforts and due diligence, and that will actually, demonstratively, adversely, and materially affect the ability of the Party to carry out its obligations under Sections 3.A(i), 4.B(iv), 4.B(v)(1), and 4.C of this Agreement:

(i) insurrection, riot, civil disturbance, sabotage, act of public enemy, explosion, nuclear incident, war, or naval blockade;

(ii) epidemic or pandemic, hurricane, tornado, landslide, earthquake, lightning, fire, windstorm, other extraordinary weather conditions preventing performance of work, or other similar Act of God; or

(iii) strikes, lockouts, or labor disputes, other than those caused by the unlawful acts of the Party, its partners, or affiliated entities.

“Uncontrollable Circumstance” does not include: (i) delays caused by weather conditions, unless the weather conditions are unusually severe or abnormal considering the time of year and the particular location involved; or (ii) economic hardship, impracticability of performance, commercial, economic, or market conditions, or a failure of performance by a contractor (except as caused by events that are Uncontrollable Circumstances as to the contractor).

City Draft 3/20/26

B. If a Party claims an Uncontrollable Circumstance, it shall, as soon as practicable after it knows or should have known of the Uncontrollable Circumstance, provide the other Party with written notice describing the details of the Uncontrollable Circumstance, the anticipated length of delay due to the Uncontrollable Circumstance, and any other effect of the Uncontrollable Circumstance on the Party's completion of the applicable obligation. If the Party timely provides such notice of the Uncontrollable Circumstance, the Party shall not be liable for a breach of this Agreement for failure or delay in complying with the applicable obligation because of the Uncontrollable Circumstance, and the time for completion of the applicable obligation shall be extended, provided that such extension of time is of no longer duration than is required by the effects of the Uncontrollable Circumstance, and that the Party continually uses reasonable efforts to alleviate and mitigate the cause and effects of the Uncontrollable Circumstance and remedy its inability to perform.

In witness whereof, the Parties have duly executed this Agreement, consisting of 16 typewritten pages excluding Exhibits A, B, and C to this Agreement, as of the Effective Date.

CITY OF DES PLAINES

CHICAGO DISTRICT CAMP GROUND ASSOCIATION

By: \_\_\_\_\_  
Its: \_\_\_\_\_  
Date: \_\_\_\_\_

Signed by:  
By: Daniel Amari  
Its: President  
Date: 4/14/2026

CHICAGO DISTRICT CAMP GROUND, INC.

Signed by:  
By: Daniel Amari  
Its: President  
Date: 4/14/2026

**EXHIBIT A**

**LEGAL DESCRIPTION OF THE PROPERTY**

ALL THAT PART OF THE NORTH ½ OF SECTION 21, TOWNSHIP 41 NORTH, RANGE 12, EAST OF THE THIRD PRINCIPAL MERIDIAN, DESCRIBED AS FOLLOWS:

COMMENCING AT THE SOUTHEAST CORNER OF THE NORTHWEST ¼ OF SAID SECTION AND RUNNING THENCE WEST ON THE SOUTH LINE OF SAID QUARTER TO THE CENTER OF THE DES PLAINES RIVER; THENCE ALONG SAID RIVER TO THE WEST LINE OF THE EAST ½ OF THE NORTHWEST ¼; THENCE NORTH ON THE WEST LINE, A DISTANCE OF 4.20 CHAINS; THENCE NORTH 89 DEGREES EAST, A DISTANCE OF 1.82 CHAINS; THENCE NORTH, A DISTANCE OF 3 CHAINS; THENCE NORTH 70 DEGREES EAST, A DISTANCE OF 5.44 CHAINS; THENCE NORTH 89 DEGREES EAST, A DISTANCE OF 4.18 CHAINS; THENCE NORTH 54 DEGREES EAST, A DISTANCE OF 3.12 CHAINS TO THE SOUTHERLY LINE OF THE RIGHT OF WAY OF THE CHICAGO AND NORTHWESTERN RAILROAD; THENCE SOUTHEASTERLY ALONG SAID SOUTHERLY LINE TO A POINT IN SAID SOUTHERLY LINE, WHICH IS 2.18 CHAINS EAST OF THE EAST LINE OF SAID NORTHWEST ¼ THENCE WEST, A DISTANCE OF 2.18 CHAINS TO THE EAST LINE OF SAID NORTHWEST ¼; THENCE SOUTH TO THE POINT OF BEGINNING, IN COOK COUNTY, ILLINOIS.

**EXHIBIT B**

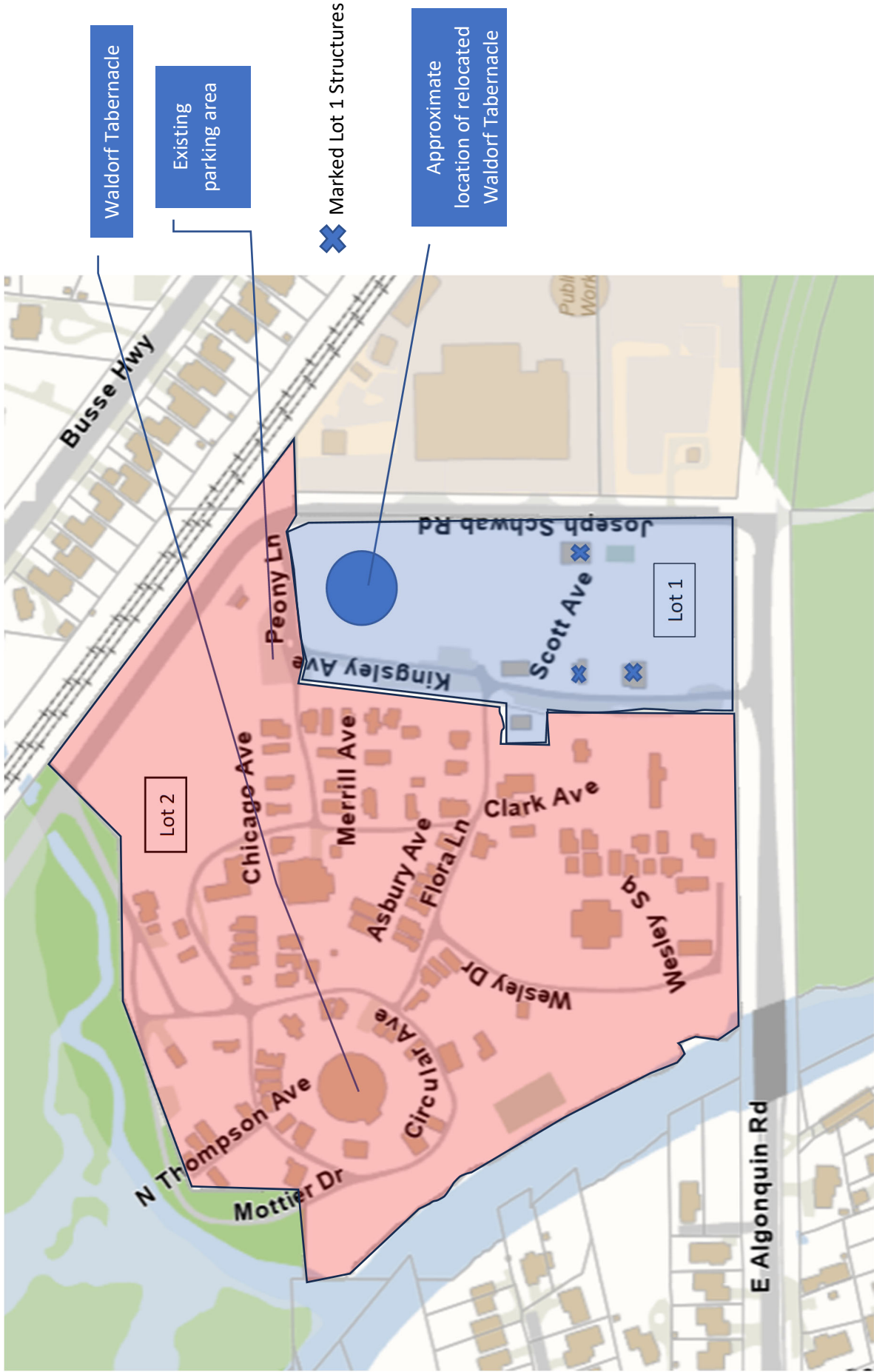

**EXHIBIT C**  
**DISMISSAL ORDER**

**IN THE CIRCUIT COURT OF COOK COUNTY, ILLINOIS**  
**SECOND MUNICIPAL DISTRICT**

|                                      |   |                         |
|--------------------------------------|---|-------------------------|
| City of Des Plaines,                 | ) |                         |
|                                      | ) |                         |
| Plaintiff,                           | ) | Case No. 2021 M2 001319 |
|                                      | ) |                         |
| v.                                   | ) |                         |
|                                      | ) |                         |
| Chicago District Camp Ground, Inc.,  | ) |                         |
| Chicago District Camp Ground         | ) |                         |
| Association, Unknown Owners and Non- | ) |                         |
| Record Claimants,                    | ) |                         |
| Defendants.                          | ) |                         |

**AGREED DISMISSAL ORDER**

This cause coming to be heard, the parties being in agreement, and the Court being advised in the premises, it is hereby ordered that:

1. This matter is dismissed without prejudice at this time pursuant to the parties' \_\_\_\_\_, 2026 "*Settlement Agreement and Mutual Release*" ("***Settlement Agreement***"), with each party to bear its own costs and attorneys' fees; upon "Closing", as provided in the Settlement Agreement, a separate order will be entered dismissing this matter with prejudice.
2. Any previously-scheduled status dates and filing deadlines are hereby stricken.
3. The court retains jurisdiction of this matter for the purpose of enforcement of the Settlement Agreement.

Agreed:

\_\_\_\_\_  
 City of Des Plaines  
 By: Its Attorney  
 Peter Friedman

\_\_\_\_\_  
 Chicago District Camp Ground, Inc.  
 Chicago District Camp Ground Association  
 By: Their Attorney  
 R. Andrew Smith

ENTERED:

Prepared by:  
 Peter M. Friedman  
 Elrod Friedman LLP  
 350 N. Clark Street, Second Floor  
 Chicago, Illinois 60654  
 Phone: (312) 528-5192  
[peter.friedman@elrodfriedman.com](mailto:peter.friedman@elrodfriedman.com)

\_\_\_\_\_  
Judge

\_\_\_\_\_  
Judge's No.



**PUBLIC WORKS AND  
ENGINEERING DEPARTMENT**

1111 Joseph J. Schwab Road  
Des Plaines, IL 60016  
P: 847.391.5464  
desplainesil.gov

**MEMORANDUM**

Date: April 23, 2026

To: Dorothy Wisniewski, City Manager

From: Jason Ostrowski, Superintendent 

Cc: Timothy Watkins, Director of Public Works and Engineering  
Thomsas Bueser, Assistant Director of Public Works

Subject: Bid Award – 2026 Fiberized Asphalt Crack Sealing Program

**Issue:** The approved 2026 budget includes funds for the fiberized asphalt crack sealing program. Two bids for this project were received on April 2, 2026.

**Analysis:** The Public Works and Engineering Department annually conducts an evaluation of local road conditions and determines the roads most suitable for sealing maintenance. The bid specifications require vendors to provide unit prices for sealing asphalt cracks per lineal foot of sealant material applied and traffic control measures. The bids received are shown in the tabulation below:

| Company          | Traffic Control | Unit Price per Lineal Foot |
|------------------|-----------------|----------------------------|
| Denler, Inc      | \$500.00        | \$0.278                    |
| SKC Construction | \$6751.00       | \$0.288                    |

Denler, Inc. submitted the lowest comparable bid for this contract, is a responsible bidder, and has worked for the City in previous years doing similar work with positive results.

**Recommendation:** We recommend awarding the 2026 Asphalt Crack Sealing-Fiberized Program contract to Denler Inc, 20502 Cherry Hill Road, Joliet, IL, 60433, per unit prices submitted in the not to exceed amount of \$100,000. Funding for this project will be the Motor Fuel Tax funds, Other Services account (230-00-000-0000.6160).

**Attachments:**  
Resolution R-119-26  
Exhibit A – Contract

CITY OF DES PLAINES

RESOLUTION R - 119 - 26

**A RESOLUTION APPROVING AN AGREEMENT WITH DENLER, INC. FOR THE 2026 ASPHALT CRACK SEALING-FIBERIZED PROGRAM.**

**WHEREAS**, Article VII, Section 10 of the 1970 Illinois Constitution authorizes the City to contract with individuals, associations, and corporations in any manner not prohibited by law or ordinance; and

**WHEREAS**, the City has appropriated funds in the Motor Fuel Tax Fund for use by the Public Works and Engineering Department during the 2026 fiscal year for the 2026 Asphalt Crack Sealing-Fiberized Program (collectively, the "**Project**"); and

**WHEREAS**, pursuant to Chapter 10 of Title 1 of the of the City of Des Plaines City Code and the City's purchasing policy, the City issued an invitation for bids for the Project; and

**WHEREAS**, the City received two bids, which were opened on April 2, 2026; and

**WHEREAS**, Denler, Inc. ("**Vendor**") submitted the lowest responsible bid for the Project; and

**WHEREAS**, the City desires to enter into an agreement with Vendor for the Project in the not-to-exceed amount of \$100,000 ("**Agreement**"); and

**WHEREAS**, the City Council has determined that it is in the best interest of the City to enter into the Agreement with Vendor for the Project in the not-to-exceed amount of \$100,000;

**NOW, THEREFORE, BE IT RESOLVED** by the City Council of the City of Des Plaines, Cook County, Illinois, in the exercise of its home rule powers, as follows:

**SECTION 1: RECITALS.** The foregoing recitals are incorporated into, and made a part of, this Resolution as findings of the City Council.

**SECTION 2: APPROVAL OF AGREEMENT.** The City Council hereby approves the Agreement with Vendor in substantially the form attached to this Resolution as **Exhibit A**, and in a final form to be approved by the General Counsel.

**SECTION 3: AUTHORIZATION TO EXECUTE AGREEMENT.** The City Council hereby authorizes and directs the Mayor and the City Clerk to execute and seal, on behalf of the City, the final Agreement.

**SECTION 4: EFFECTIVE DATE.** This Resolution shall be in full force and effect from and after its passage and approval according to law.

**PASSED** this \_\_\_\_ day of \_\_\_\_\_, 2026.

**APPROVED** this \_\_\_\_ day of \_\_\_\_\_, 2026.

**VOTE:** AYES \_\_\_\_ NAYS \_\_\_\_ ABSENT \_\_\_\_

---

**MAYOR**

ATTEST:

Approved as to form:

---

**CITY CLERK**

---

**Peter M. Friedman, General Counsel**

DP-Resolution Approving Agreement for 2026 Asphalt Crack Sealing Contract with Denler



Contractor's Name

Denler, Inc.

Contractor's Address

20502 S. Cherry Hill Rd.

City

Joliet

State

IL

Zip Code

60433

STATE OF ILLINOIS

Local Public Agency

CITY OF DES PLAINES

County

Cook

Section Number

26-00000-05-GM

Street Name/Road Name

VARIOUS LOCATIONS

Type of Funds

MFT

CONTRACT BOND (when required)

**For a County and Road District Project**

Submitted/Approved

Highway Commissioner Signature

Date

|  |  |
|--|--|
|  |  |
|--|--|

Submitted/Approved

County Engineer/Superintendent of Highways

Date

|  |  |
|--|--|
|  |  |
|--|--|

**For a Municipal Project**

Submitted/Approved/Passed

Signature

Date

|  |  |
|--|--|
|  |  |
|--|--|

Official Title

MAYOR

**Department of Transportation**

Concurrence in approval of award

Regional Engineer Signature

Date

|  |  |
|--|--|
|  |  |
|--|--|

|                     |                        |        |                |
|---------------------|------------------------|--------|----------------|
| Local Public Agency | Local Street/Road Name | County | Section Number |
| CITY OF DES PLAINES | VARIOUS LOCATIONS      | Cook   | 26-00000-05-GM |

1. THIS AGREEMENT, made and concluded the 4th day of May 2026 between the City of Des Plaines, known as the party of the first part, and Denler, Inc., its successor, and assigns, known as the party of the second part.

2. For and in consideration of the payments and agreements mentioned in the Proposal hereto attached, to be made and performed by the party of the first part, and according to the terms expressed in the Bond referring this contract, the party of the second part agrees with said party of the first part, at its own proper cost and expense, to do all the work, furnish all materials and all labor necessary to complete the work in accordance with the plans and specifications hereinafter described, and in full compliance with all of the terms of this contract.

3. It is also understood and agreed that the LPA Formal Contract Proposal, Special Provisions, Affidavit of Illinois Business Office, Apprenticeship or Training Program Certification, and Contract Bond hereto attached, and the Plans for Section 25-00000-05-GM in CITY OF DES PLAINES, approved by the Illinois Department of Transportation on \_\_\_\_\_, are essential documents of this contract and are a part hereof.

4. IN WITNESS WHEREOF, the said parties have executed this contract on the date above mentioned.

Attest: The City of Des Plaines

|       |      |
|-------|------|
| Clerk | Date |
|       |      |

|                         |      |
|-------------------------|------|
| Party of the First Part | Date |
| By:                     |      |

(SEAL)

*(If a Corporation)*

|                     |
|---------------------|
| Corporate Name      |
| <u>Denler, Inc.</u> |

|                                     |      |
|-------------------------------------|------|
| President, Party of the Second Part | Date |
| By:                                 |      |

(SEAL)

*(If a Limited Liability Corporation)*

|          |
|----------|
| LLC Name |
|          |

|  |
|--|
| Manager or Authorized Member, Party of the Second Part |
| By:  |

*(If a Partnership)*

|         |      |
|---------|------|
| Partner | Date |
|         |      |

Attest:

|           |      |
|-----------|------|
| Secretary | Date |
|           |      |

|         |      |
|---------|------|
| Partner | Date |
|         |      |

(SEAL)

Partners doing Business under the firm name of  
Party of the Second Part

|  |
|--|
|  |
|--|

*(If an individual)*

|                          |      |
|--------------------------|------|
| Party of the Second Part | Date |
|                          |      |

CITY OF DES PLAINES

CONTRACT FOR

2026 Asphalt Crack Sealing-Fiberized MFT-26-00000-05-GM

Full Name of Bidder Denler, Inc. ("Bidder")
Principal Office Address 20502 S. Cherry Hill Rd., Joliet, IL 60433
Local Office Address same
Contact Person David J. Denler Telephone Number 708-479-5005

TO: City of Des Plaines ("Owner")
1420 Miner Street
Des Plaines, Illinois 60016
Attention: none

Bidder warrants and represents that Bidder has carefully examined the Work Site described below and its environs and has reviewed and understood all documents included, referred to, or mentioned in this bound set of documents, including Addenda Nos. [if none, write "NONE"], which are securely stapled to the end of this Contract.

consistent therewith, with only new, undamaged, and first quality equipment, materials, and supplies.

B. Performance Standards. If this Contract is accepted, Bidder proposes and agrees that all Work shall be fully provided, performed, and completed in accordance with the specifications attached hereto and by this reference made a part of this Contract. No provision of any referenced standard, specification, manual or code shall change the duties and responsibilities of Owner or Bidder from those set forth in this Contract. Whenever any equipment, materials, or supplies are specified or described in this Contract by using the name or other identifying feature of a proprietary product or the name or other identifying feature of a particular manufacturer or vendor, the specific item mentioned shall be understood as establishing the type, function, and quality desired. Other manufacturers' or vendors' products may be accepted, provided that the products proposed are equivalent in substance and function to those named as determined by Owner in its sole and absolute discretion.

1. Work Proposal

A. Contract and Work. If this Contract is accepted, Bidder proposes and agrees that Bidder shall, at its sole cost and expense, provide, perform, and complete, in the manner specified and described, and upon the terms and conditions set forth, in this Contract and Owner's written notification of acceptance in the form included in this bound set of documents, all of the following, all of which is herein referred to as the "Work":

C. Responsibility for Damage or Loss. If this Contract is accepted, Bidder proposes and agrees that Bidder shall be responsible and liable for, and shall promptly and without charge to Owner repair or replace, damage done to, and any loss or injury suffered by, Owner, the Work, the Work Site, or other property or persons as a result of the Work.

- 1. Labor, Equipment, Materials and Supplies. Provide, perform, and complete, in the manner specified and described in this Contract/Proposal, all necessary work, labor, services, transportation, equipment, materials, supplies, information, data, and other means and items necessary for the 2026 Asphalt Crack Sealing-Fiberized-Program-MFT-26-00000-05-GM within the City of Des Plaines designated areas;
2. Permits. Procure and furnish all permits, licenses, and other governmental approvals and authorizations necessary in connection therewith;
3. Bonds and Insurance. Procure and furnish all bonds and all insurance certificates and policies of insurance specified in this Contract;
4. Taxes. Pay all applicable federal, state, and local taxes;
5. Miscellaneous. Do all other things required of Bidder by this Contract; and
6. Quality. Provide, perform, and complete all of the foregoing in a proper and workmanlike manner, consistent with highest standards of professional and construction practices, in full compliance with, and as required by or pursuant, to this Contract, and with the greatest economy, efficiency, and expedition

D. Inspection/Testing/Rejection. Owner shall have the right to inspect all or any part of the Work and to reject all or any part of the Work that is, in Owner's judgment, defective or damaged or that in any way fails to conform strictly to the requirements of this Contract and Owner, without limiting its other rights or remedies, may require correction or replacement at Bidder's cost, perform or have performed all Work necessary to complete or correct all or any part of the Work that is defective, damaged, or nonconforming and charge Bidder with any excess cost incurred thereby, or cancel all or any part of any order or this Contract. Work so rejected may be returned or held at Bidder's expense and risk.

2. Contract Price Proposal

If this Contract is accepted, Bidder proposes, and agrees, that Bidder shall take in full payment for all Work and other matters set forth under Section 1 above, including overhead and profit; taxes, contributions, and premiums; and compensation to

all subcontractors and suppliers, the compensation set forth below.

A. Schedule of Prices. For providing, performing, and completing all Work, the

TOTAL CONTRACT PRICE (in numbers):

\$ 56,100.00

B. Basis for Determining Prices. It is expressly understood and agreed that:

1. All prices stated in the Schedule of Prices are firm and shall not be subject to escalation or change;

2. Owner is not subject to state or local sales, use, and excise taxes, that no such taxes are included in the Schedule of Prices, and that all claim or right to claim any additional compensation by reason of the payment of any such tax is hereby waived and released; and

3. All other applicable federal, state, and local taxes of every kind and nature applicable to the Work are included in the Schedule of Prices; and

4. The approximate quantities set forth in the Schedule of Prices for each Unit Price Item are Owner's estimate only, that Owner reserves the right to increase or decrease such quantities, that payment for each Unit Price Item shall be made only on the actual number of acceptable units of such Unit Price Item installed complete in place in full compliance with this Contract/Proposal, and that all claim or right to dispute or complain of any such estimated quantity, or to assert that there was any misunderstanding in regard to the nature or amount of any Unit Price Item to be provided or performed, is hereby waived and released; and

5. Any items of Work not specifically listed or referred to in the Schedule of Prices, or not specifically included for payment under any Unit Price Item, shall be deemed incidental to the Contract Price, shall not be measured for payment, and shall not be paid for separately except as incidental to the Contract Price, including without limitation extraordinary equipment repair, the cost of transportation, packing, cartage, and containers, the cost of preparing schedules and submittals, the cost or rental of small tools or buildings, the cost of utilities and sanitary conveniences, and any portion of the time of Bidder, its superintendents, or its office and engineering staff.

C. Time of Payment. It is expressly understood and agreed that all payments shall be made in accordance with the following schedule:

Bidder will invoice Owner for all Work completed, and Owner will pay Bidder all undisputed amounts no later than 45 days after receipt by Owner of each invoice.

All payments may be subject to deduction or setoff by reason of any failure of Bidder to perform under this Contract/Proposal. Each payment shall include Bidder's certification of the value of, and partial or final waivers of lien covering, all Work for which payment is then requested and Bidder's certification that all prior payments have been properly

applied to the payment or reimbursement of the costs with respect to which they were paid.

### 3. Contract Time

If this Contract is accepted, Bidder proposes and agrees that Bidder shall commence the Work within 10 days after Owner's acceptance of the Contract provided Bidder shall have furnished to Owner all bonds and all insurance certificates and policies of insurance specified in this Contract (the "Commencement Date"). If this Contract is accepted, Bidder proposes and agrees that Bidder shall perform the Work diligently and continuously and shall complete the Work not later than September 1, 2026.

Owner may terminate this Contract/Proposal at its convenience by providing Bidder 30 days advance written notice thereof. At all times during the Term and any Renewal Term, Bidder proposes and agrees that Bidder shall perform the Work diligently and continuously and shall complete the Work in accordance with this Contract/Proposal, as directed by Owner, and more fully described in Attachment A.

**If, at any time during the term of the Contract, the Owner determines that the Work is not being completed by Bidder in full compliance with specifications and as required by or pursuant to this Contract, then Owner may, after providing Bidder with notice of such deficiency in performance and providing Bidder with one (1) business days to cure such deficiency, invoke its remedies under this Contract or may, in Owner's sole and absolute discretion, permit Bidder to complete the Work but charge to Bidder, and deduct from any payments to Bidder under this Contract, whether or not previously approved, administrative expenses and costs for each day completion of the Work is delayed beyond the Completion Date, computed on the basis of the following per diem administrative charge, as well as any additional damages caused by such delay:**

Per Diem Administrative Charge:

\$ 250.00 per day/occurrence

**A second occurrence of a specific deficiency in performance shall automatically trigger Bidder's obligation to pay the Per Diem Administrative Charge. Any Per Diem Administrative Charges assessed against Bidder will be deducted from any funds owed by Owner to Bidder.**

### 4. Financial Assurance

A. Bonds. If this Contract is accepted, Bidder proposes and agrees that Bidder shall provide a Performance Bond and a Labor and Material Payment Bond, on forms provided by, or otherwise acceptable to, Owner, from a surety company acceptable to Owner, each in the penal sum of the Contract Price, within 10 days after Owner's acceptance of this Contract.

B. Insurance. If this Contract is accepted, Bidder proposes and agrees that Bidder shall provide certificates and policies of insurance evidencing the minimum insurance coverage and limits set forth below within 10 days after Owner's acceptance of this Contract. Such insurance shall be in form, and from companies, acceptable to Owner and shall name Owner, including its Council members and elected and

appointed officials, its officers, employees, agents, attorneys, consultants, and representatives, as an Additional Insured. The insurance coverage and limits set forth below shall be deemed to be minimum coverage and limits and shall not be construed in any way as a limitation on Bidder's duty to carry adequate insurance or on Bidder's liability for losses or damages under this Contract. The minimum insurance coverage and limits that shall be maintained at all times while providing, performing, or completing the Work are as follows:

1. Workers' Compensation and Employer's Liability

Limits shall not be less than:

Worker's Compensation: Statutory

Employer's Liability: \$500,000 each accident-injury; \$500,000 each employee-disease; \$500,000 disease-policy.

Such insurance shall evidence that coverage applies to the State of Illinois and provide a waiver of subrogation in favor of Owner.

2. Commercial Motor Vehicle Liability

Limits for vehicles owned, non-owned or rented shall not be less than:

\$1,000,000 Bodily Injury and Property Damage Combined Single Limit

3. Commercial General Liability

Limits shall not be less than:

\$1,000,000 Bodily Injury and Property Damage Combined Single Limit.

Coverage is to be written on an "occurrence" basis.  
Coverage to include:

- Premises Operations
- Products/Completed Operations
- Independent Contractors
- Personal Injury (with Employment Exclusion deleted)
- Broad Form Property Damage Endorsement
- "X," "C," and "U"
- Contractual Liability

Contractual Liability coverage shall specifically include the indemnification set forth below.

4. Umbrella Liability

Limits shall not be less than:

\$2,000,000 Bodily Injury and Property Damage Combined Single Limit.

This Coverage shall apply in excess of the limits stated in 1, 2, and 3 above.

C. Indemnification. If this Contract is accepted, Bidder proposes and agrees that Bidder shall indemnify, save harmless, and defend Owner against all damages, liability,

claims, losses, and expenses (including attorneys' fees) that may arise, or be alleged to have arisen, out of or in connection with Bidder's performance of, or failure to perform, the Work or any part thereof, or any failure to meet the representations and warranties set forth in Section 6 of this Contract.

D. Penalties. If this Contract is accepted, Bidder proposes and agrees that Bidder shall be solely liable for any fines or civil penalties that are imposed by any governmental or quasi-governmental agency or body that may arise, or be alleged to have arisen, out of or in connection with Bidder's performance of, or failure to perform, the Work or any part thereof.

5. Firm Contract

All prices and other terms stated in this Contract are firm and shall not be subject to withdrawal, escalation, or change provided Owner accepts this Contract within 45 days after the date the bidder's contract proposal is opened.

6. Bidder's Representations and Warranties

To induce Owner to accept this Contract, Bidder hereby represents and warrants as follows:

A. The Work. The Work, and all of its components, (1) shall be of merchantable quality; (2) shall be free from any latent or patent defects and flaws in workmanship, materials, and design; (3) shall strictly conform to the requirements of this Contract, including without limitation the performance standards set forth in Section 1B of this Contract; and (4) shall be fit, sufficient, and suitable for the purposes expressed in, or reasonably inferred from, this Contract and the warranties expressed herein shall be in addition to any other warranties expressed or implied by law, which are hereby reserved unto Owner. Bidder, promptly and without charge, shall correct any failure to fulfill the above warranty at any time within two years after final payment or such longer period as may be prescribed in the performance standards set forth in Section 1B of this Contract or by law. The above warranty shall be extended automatically to cover all repaired and replacement parts and labor provided or performed under such warranty and Bidder's obligation to correct Work shall be extended for a period of two years from the date of such repair or replacement. The time period established in this Section 6A relates only to the specific obligation of Bidder to correct Work and shall not be construed to establish a period of limitation with respect to other obligations that Bidder has under this Contract.

B. Compliance with Laws. The Work, and all of its components, shall be provided, performed, and completed in compliance with, and Bidder agrees to be bound by, all applicable federal, state, and local laws, orders, rules, and regulations, as they may be modified or amended from time to time, including without limitation the Illinois Prevailing Wage Act, 820 ILCS 130/0.01 et seq. and any other prevailing wage laws; any statutes requiring preference to laborers of specified classes; the Illinois Steel Products Procurement Act, 30 ILCS 565/1 et seq.; any statutes prohibiting discrimination because of, or requiring affirmative action based on, race, creed, color, national origin, age, sex, or other prohibited classification; and any statutes regarding safety or the performance of the Work.

C. Prevailing Wage Act. This Contract calls for the construction of a "public work," within the meaning of the Illinois Prevailing Wage Act, 820 ILCS 130/0.01 et seq. (the "Act"). If the Illinois Department of Labor revises the prevailing rate of hourly wages to be paid, the revised rate will apply to this Contract. Bidder and any subcontractors rendering services under this Contract must comply with all requirements of the Act, including but not limited to, all wage, notice, and record-keeping duties and certified payrolls.

D. Not Barred. Bidder is not barred by law from contracting with Owner or with any other unit of state or local government as a result of (i) a violation of either Section 33E-3 or Section 33E-4 of Article 33 of the Criminal Code of 1961, 720 ILCS 5/33E-1 et seq.; or (ii) a violation of the USA Patriot Act of 2001, 107 Public Law 56 (October 26, 2001) (the "Patriot Act") or other statutes, orders, rules, and regulations of the United States government and its various executive departments, agencies and offices related to the subject matter of the Patriot Act, including, but not limited to, Executive Order 13224 effective September 24, 2001. Bidder is not acting, directly or indirectly, for or on behalf of any person, group, entity or nation named by the United States Treasury Department as a Specially Designated National and Blocked Person, or for or on behalf of any person, group, entity or nation designated in Presidential Executive Order 13224 as a person who commits, threatens to commit, or supports terrorism; and Bidder is not engaged in this transaction directly or indirectly on behalf of, or facilitating this transaction directly or indirectly on behalf of, any such person, group, entity or nation.

E. Qualified. Bidder has the requisite experience minimum of 5 years, ability, capital, facilities, plant, organization, and staff to enable Bidder to perform the Work successfully and promptly and to commence and complete the Work within the Contract Price and Contract Time set forth above. Bidder warrants and represents that it has met and will meet all required standards set forth in Owner's Responsible Bidder Ordinance M-7-20, including, without limitation, The bidder actively participates, and has actively participated for at least 12 months before the date of the bid opening, in apprenticeship and training programs approved and registered with the United States department of labor bureau of apprenticeship and training for each of the trades of work contemplated under the awarded contract for all bidders and subcontractors. For the purposes of this subsection, a bidder or subcontractor is considered an active participant in an apprenticeship and training program if all eligible employees have either: (i) completed such a program, or (ii) were enrolled in such a program prior to the solicitation date and are currently participating in such program." performing Work under this Contract.

## 7. Acknowledgements

In submitting this Contract, Bidder acknowledges and agrees that:

A. Reliance. Owner is relying on all warranties, representations, and statements made by Bidder in this Contract.

B. Reservation of Rights. Owner reserves the right to reject any and all proposals, reserves the right to reject the low

price proposal, and reserves such other rights as are set forth in the Instructions to Bidders.

C. Acceptance. If this Contract is accepted, Bidder shall be bound by each and every term, condition, or provision contained in this Contract and in Owner's written notification of acceptance in the form included in this bound set of documents.

D. Remedies. Each of the rights and remedies reserved to Owner in this Contract shall be cumulative and additional to any other or further remedies provided in law or equity or in this Contract.

E. Time. Time is of the essence for this Contract and, except where stated otherwise, references in this Contract to days shall be construed to refer to calendar days.

F. No Waiver. No examination, inspection, investigation, test, measurement, review, determination, decision, certificate, or approval by Owner, whether before or after Owner's acceptance of this Contract; nor any information or data supplied by Owner, whether before or after Owner's acceptance of this Contract; nor any order by Owner for the payment of money; nor any payment for, or use, possession, or acceptance of, the whole or any part of the Work by Owner; nor any extension of time granted by Owner; nor any delay by Owner in exercising any right under this Contract; nor any other act or omission of Owner shall constitute or be deemed to be an acceptance of any defective, damaged, or nonconforming Work, nor operate to waive or otherwise diminish the effect of any representation or warranty made by Bidder; or of any requirement or provision of this Contract; or of any remedy, power, or right of Owner.

G. Severability. The provisions of this Contract/ Proposal shall be interpreted when possible to sustain their legality and enforceability as a whole. In the event any provision of this Contract shall be held invalid, illegal, or unenforceable by a court of competent jurisdiction, in whole or in part, neither the validity of the remaining part of such provision, nor the validity of any other provisions of this Contract shall be in any way affected thereby.

H. Amendments. No modification, addition, deletion, revision, alteration, or other change to this Contract shall be effective unless and until such change is reduced to writing and executed and delivered by Owner and Bidder, except that Owner has the right, by written order executed by Owner, to make changes in the Work ("Change Order"). If any Change Order causes an increase or decrease in the amount of the Work, then an equitable adjustment in the Contract Price or Contract Time may be made. No decrease in the amount of the Work caused by any Change Order shall entitle Bidder to make any claim for damages, anticipated profits, or other compensation.

I. Assignment. Neither this Contract, nor any interest herein, shall be assigned or subcontracted, in whole or in part, by Bidder except upon the prior written consent of Owner.

J. Governing Law. This Contract, and the rights of the parties under this Contract shall be interpreted according to the internal laws, but not the conflict of law rules, of the State of Illinois. Every provision of law required by law to be inserted into this Contract/Proposal shall be deemed to be inserted herein.

By submitting this Contract proposal in response to this Invitation to Bid, Bidder hereby represents, warrants, and certifies that:

- Bidder has carefully examined and read the ITB and all related documents in their entirety.
- The person signing the Contract proposal on behalf of Bidder is fully authorized to execute the Contract and bind Bidder to all of the terms and provisions of the Contract.
- Bidders has provided a list of client references including at least 5 Municipal References
- Bidder has fully completed the entire Contract form, including the Total Contract Price.
- Bidder has submitted a certified check or bid bond, as required by the Instructions to Bidders
- Bidder has checked the City's website for any addenda issued in connection with this ITB, hereby acknowledges receipt of Addenda Nos. [BIDDERS MUST INSERT ALL ADDENDA NUMBERS], has attached these addenda to Bidder's contract proposal, and acknowledges and agrees that, if Bidder's contract proposal is accepted, these addenda will be incorporated into the Contract and will be binding upon Bidder.
- Bidder has submitted its Contract proposal in a sealed envelope that bears the full legal name of Bidder and the name of the Contract.

Dated: 3/27, 2026

Bidder's Status:  IL Corporation ( ) Partnership ( ) Individual Proprietor  
 (State) (State)

Bidder's Name: Denler, Inc.

Doing Business As (if different): \_\_\_\_\_

Signature of Bidder or Authorized Agent: *David J Denler* Date: 3/27/26

(corporate seal) Printed Name: David J Denler  
 (if corporation) Title/Position: President

Bidder's Business Address: 20502 S. Cherry Hill Rd. Joliet, IL 60433

Bidder's Business Telephone: 708-479-5005 Facsimile: 708-479-5015

If a corporation or partnership, list all officers or partners:

| NAME           | TITLE     | ADDRESS                                   |
|----------------|-----------|---|
| David J Denler | President | 20502 S. Cherry Hill Rd. Joliet, IL 60433 |
| David J Denler | Secretary | 20502 S. Cherry Hill Rd. Joliet, IL 60433 |
|                |           |   |

State of Illinois  
DEPARTMENT OF TRANSPORTATION  
Bureau of Local Roads and Streets

SPECIAL PROVISION  
FOR  
CRACK FILLING BITUMINOUS PAVEMENT WITH FIBER-ASPHALT

Effective: October 1, 1991  
Revised: January 1, 2007

All references to Section or Articles in this specification shall be construed to mean a specific Section or Article of the Standard Specifications for Road and Bridge Construction, adopted by the Department of Transportation

Filling Cracks (Flexible Pavement). This work consists of cleaning and filling transverse and longitudinal joints and cracks in existing bituminous flexible pavement with fiber modified asphalt cement as shown in the plan details, as directed by the Engineer, and as described herein.

Materials. Materials shall meet the requirement of the following Articles of Section 1000 – Materials:

| Item                                   | Article         |
|--|-----------------|
| (a) Bituminous Materials (Note 1)..... | 1032.01-1032.05 |

Note 1 - Asphalt cement shall be PG 58-28, PG 58-22, or PG 64-22.

Fibers should be short cut polypropylene fibers meeting the properties listed below:

|  |            |              |
|--|------------|--------------|
| Length,  | mm:        | 8 - 12       |
| Denier   | :          | 13 - 16      |
| Crimps   | :          | None         |
| Tensile Strength, minimum,                           | MPa (psi): | 275 (40,000) |
| Specific Gravity (typical)                           | :          | 0.91         |
| Moisture Regain @ 21 °C (70 °F) and 65% RH (typical) | %:         | 0.1          |

The fiber may be accepted on certification from the manufacturer that it meets the specified requirements.

Equipment. An oil jacketed double wall kettle equipped with an agitator (reversing rotary auger action) and separate thermometers for the oil bath and mixing chamber will be required. The unit shall also be equipped with a reversible hydraulic 50 mm (2 inch) hot asphalt pump and a recirculating pump to circulate the oil bath. An air compressor capable of producing a minimum 620 kPa (90 psi) at the end of the discharge hose will be required.

Preparation of Mixture. The fiber modified asphalt cement or fiber-asphalt shall consist of a minimum of 8.0% by weight fiber in the fiber-asphalt mixture. Operating temperatures in the kettle shall be between 124 and 141 °C (255 and 285 °F). The temperature shall never exceed 143 °C (290 °F) as the fibers will melt into the asphalt cement.

Construction Methods. The fiber-asphalt filler shall be applied only when the joints and cracks are dry and free of dirt, vegetation, debris and loose filler. The joints and cracks shall be blown out with the 620 kPa (90 psi) compressed air. The blowing out operations shall be kept close to the filling operations to prevent debris being carried back into the cracks before filling. Routing will not be required. A hot compressed air lance meeting the approval of the engineer may be used to clean the cracks.

The fiber-asphalt filler shall be applied using a pressurized wand delivery system with such devices as necessary to fill the cracks and form a nominal 3 mm (0.125 inch) thick by 75 mm (3 inch) wide overseal band centered so that the center of the 75 mm (3 inch) wide band is within 25 mm (1 inch) of the crack. The fiber-asphalt filler shall be applied taking care to not use excessive material in either thickness or location. The engineer will determine the extent that fine cracks are filled. Care should be taken to not place filler on top of pavement markings, manholes and drainage castings.

The ambient temperature during filling shall be above 4 °C (40 °F) and below 29 °C (85 °F). The filler must cure before being opened to traffic. The contractor may use fine sand, mineral filler or portland cement to dust the filler if necessary to more quickly open the road to traffic. Dusting will be considered incidental.

A technical representative from the fiber manufacturer shall be available for initial filling work. Any suggestions or recommendations shall be submitted to the Engineer for approval.

Method of Measurement. Filling of cracks will be measured for payment in kilograms (pounds) of fiber-asphalt used.

Basis of Payment. This work will be paid for at the contract unit price per kilogram (pound) of FIBER-ASPHALT. The unit price shall include the cleaning of the joints and cracks and the furnishing and placing of the filler.

## SPECIFICATIONS

- Crack Sealing Asphalt Pavement: This work shall be done in accordance with the latest edition of Section 451 of the Standard Specification for Road and Bridge Construction except as amended or modified herein.
  1. The Contractor shall be responsible for sweeping and cleaning streets to make sure the street surface is in an acceptable condition after crack sealing. The Contractor shall clean the driveways and lawns of all loose materials and debris at the end of each day's operation. All loose material and debris ground/evacuated from the cracks shall be removed from the pavement surface by means of mechanical sweepers or hand brooms within 72 hours. Contractor is responsible for satisfactory removal and disposal of all waste generated from the work. Pricing for sweeping/cleaning of streets after crack sealing will be included in the unit pricing.

**STREET SWEEPING:**

The Contractor shall be responsible for sweeping and cleaning streets to make sure the street surface is in an acceptable condition before and after crack filling. The Contractor shall clean the residents' driveway pavement, apron and lawn of all loose materials and debris at the end of each day's operation and as required at other times. All loose material and debris evacuated from the cracks shall be removed from the pavement surface by means of mechanical sweepers or hand brooms within 72 hours. This work is included in the payment for CRACKFILLING-FIBERIZED.

**DISPOSAL OF DEBRIS, EXCESS MATERIALS AND EXCAVATED OR REMOVED MATERIALS:**

The Contractor shall be responsible for satisfactory removal and disposal of all waste material, asphalt, concrete, stone, dirt, or debris generated in the course of the work. Removal and disposal of surplus, unstable, and unsuitable materials and organic waste shall follow Section 202 of the Standard Specifications. All removal or excavation items being disposed of at a landfill or clean construction and demolition debris (CCDD) fill site shall meet the requirements of Public Act 96-1416 and Section 107 of the Standard Specifications. All costs associated with meeting these requirements shall be included in the unit price cost for the associated removal or excavation items in the contract. These costs shall include but are not limited to all required testing, lab analysis, certification by a licensed professional engineer, and State or Local tipping fees.

The Contractor shall load the removed pieces of curb and gutter, sidewalk, driveway and street pavements, etc., directly onto trucks, haul it away, and dispose of it. The temporary storing of excavated materials on the parkways, and rehandling them later for disposal will not be allowed due to additional damage caused to tree root systems, parkways, existing equipment, and conditions. It shall be the Contractor's responsibility to find an approved dumpsite for debris and any excavated materials. The City will not provide for one. The stockpiling of excavated or backfill material within the roadway overnight shall not be permitted.

**MATERIAL INSPECTION AND TESTING:**

No material of any kind shall be used until it has been approved by the City. All material used shall meet the requirements of IDOT and as outlined in these specifications.

Samples of material will be collected in the field at random for laboratory analysis. The sampling and testing will be in accordance with the Provisions of Article 106.03 and 106.04 of the Standard Specifications.

The Contractor shall provide the City with letters of certification from each supplier that all materials used in the project comply with the Standard Specifications and Special Provisions indicated. Final payment will not be made until all letters of certification have been received.

**JOINT & CRACKFILL - (FIBERIZED SEALANT):**

This item of work shall consist of furnishing all labor, equipment, and materials for cleaning and waterproofing miscellaneous cracks and transverse and longitudinal cracks using asphalt reinforced with polypropylene fiber.

Materials:

The joint/crack sealant shall consist of a mixture of 8.0% minimum by weight polypropylene fibers with liquid asphalt cement. **The use of ready-mixed fiberized asphalt blocks shall not be permitted.** The asphalt cement shall be PG 64-22 conforming to AASHTO MP1 with a penetration range of 60 to 100.

Fibers shall be short cut polypropylene fibers, and a certificate from the supplier showing that the fibers meet the physical properties listed below shall be required.

|                                    |                               |
|------------------------------------|-------------------------------|
| Length                             | 8-12 mm                       |
| Denier                             | 13-16                         |
| Crimps:                            | None                          |
| Tensile Strength:                  | 275 MPa (40,000 psi), minimum |
| Specific Gravity:                  | 0.91 (typical)                |
| Moisture Regain @ 70°F and 65% RH: | 0.1% (typical)                |

Preparation of Mixture:

The sealant materials shall be combined in an oil jacketed double wall kettle (minimum 1350L (350 Gal.) capacity) equipped with an agitator (reversing rotary auger action), separate thermometers for the oil bath and mixing chamber. The unit shall also be equipped with a reversible hydraulic 50mm (2") hot asphalt pump and a recirculating pump to circulate the oil bath. Operating temperature in the kettle should be 124-141°C (255-285°F), and should never exceed 143°C (290°F). At the time of placement of the mixture, the surfaces to be sealed shall be dry, and the ambient temperature shall be above 4°C (40°F), and less than 29°C (85°F). If work is in progress and the ambient temperature reaches 29°C (85°F), the work must stop.

Construction Methods:

Any cracks, voids or joints less than 2" (50 mm) in width shall be filled and sealed as described hereafter. Any cracks and joints greater than 2" (50 mm) shall not be sealed without the approval of the Engineer. Curblin joints may or may not be sealed in contract work.

The crackfill membrane shall be applied only when the joints and cracks and adjacent pavement surfaces are dry and free of dirt, vegetation, debris and loose sealant. Physical routing of cracks to provide a square cut reservoir will generally not be required. All cracks and joints to be sealed shall be cleaned by air blasting, hand tools, wire wheel, and/or by other methods approved by the Engineer to remove all foreign material for proper bonding of the sealant. The sealing material shall be applied to form a water-proofing, stress absorbing membrane centered within 1' (25 mm) of the crack or joint.

The mixture shall be installed under high pressure 100° PSI (689 kPa) directly into and over the crack or joint. The crack shall be completely filled to its full depth and a membrane 1/8 ± 1/16 inch (3.18mm ± 1.59 mm) thick by 3" (76 mm) wide (nominal measurements) shall be formed on the surface of the pavement.

The Contractor is strongly cautioned against the excessive use of crackfill material in either thickness or location. If the City determines that sealant is being improperly applied or

wasted, then a quantity of 2 pounds of Fiberized joint sealer, per foot of errant sealant applied, shall be deducted from payments due the Contractor. In addition, the Contractor shall be responsible and will not be paid for any material placed in excess of 103% of the historic application rates of 0.18 pounds per square yard for streets designated as a Light application, 0.25 pounds per square yard for Medium application and 0.35 pounds per square yard for Heavy application.

The sealant material shall be placed with special care such that the material does not come into contact with any manhole, appurtenance frame, lid or any thermoplastic pavement markings. The Contractor shall immediately remove any misplaced sealant and clean the frame or replace any pavement markings damaged at the Contractor's sole expense. Repairs shall be to the complete satisfaction of the Engineer. Should the Contractor choose not to repair the damage, then the Engineer may order the work to be done by others, the cost of such work to be deducted from payments due the Contractor.

Traffic shall not be allowed on the sealant until properly cured. The sealant shall be dusted with fine aggregate (F A-6) if the ambient temperature is greater than 24°C (75°F), and it is necessary to open the road immediately.

The Contractor shall obtain a weight certification each day and shall submit the documentation to the Engineer by the end of each day. The Contractor shall perform a yield check each day, comparing the results to the estimated amount of sealant provided in these specifications. The Contractor shall submit the results of the yield check to the Roadway Foreman or his/her designee at the end of each day. Work shall not begin each day until all weight certifications and the yield check for the previous day's work have been submitted to the Engineer.

Payment for this item of work shall constitute full compensation for furnishing, hauling, preparing, and placing materials, for preparation of cracks and joints, clean up for disposal of surplus materials, and for labor, equipment, and tools necessary to complete this work as specified.

Joint Sealant will be paid for at the contract unit price per POUND applied for "CRACKFILLING - FIBERIZED."

**FINE AGGREGATE (FA-6):**

This item of work shall consist of providing and applying to the freshly laid sealant a dusting coat of Fine Aggregate (FA-6) or limestone screening where directed by the Engineer. The Contractor is cautioned on the excessive use of sand.

The Contractor shall be responsible for sweeping and cleaning streets to make sure the street surface is in an acceptable condition after crack filling. All loose fine aggregates shall be removed from the pavement surface by means of mechanical sweepers or hand brooms within 72 hours. The Mechanical sweeping, hand brooming or other methods as required to clean-up fine aggregates will be included in the payment for this item.

Sanding of the sealant will be paid for at the contract unit price per TON applied for "FINE AGGREGATE (FA-6)."

**TRAFFIC CONTROL AND PROTECTION:**

The Contractor shall obtain, erect, maintain and remove all signs, barricades, flagmen and other traffic control devices as may be necessary for the purpose of regulating, warning or guiding traffic. Placement and maintenance of all traffic control devices shall be in accordance with the applicable parts Maintenance Projects and the Illinois Manual on Uniform Traffic Control Devices for Streets and Highways.

All of the Contractor's workers must wear high visibility apparel (with highly reflective material for night operation) at all times during work operations within the right-of-way as required by the MUTCD 6D.03.

When requested by the City, on streets where crackfiller will be applied, the Contractor shall distribute by hand a typed notice furnished by the City to residences and businesses abutting the project. The notice shall be delivered three(3) to five (5) days before beginning the crackfill application on that street. The Contractor shall also distribute by hand a typed notice approved by the City to be placed on the windshields of all cars parked on the project the evening before treatment.

When temporary prohibition of on-street parking will be necessary to accomplish this work, the Contractor shall place "No Parking" portables or "No Parking" signs (cardboard) whichever is applicable for the particular street. In addition, the Contractor shall also post said streets at least twenty-four (24) hours prior to beginning work with "No Parking" signs legibly marked with the date and time of restricted parking. Parking restriction notices will not be furnished by the City. Distribution of the notices shall be included in cost for the work and approved by the City.

When "No Parking" signs have been posted, the Contractor shall provide written notice to the Streets Foreman and Police Department after regular hours stating the Construction Company name, the contract work being completed, the street or streets posted, the time and date posted, and shall request that Police Department personnel check the posting.

The streets under restoration may not be closed to through traffic during construction. The Contractor will provide access for through traffic. Construction operations will be confined to one traffic lane with one or more lanes open to traffic. When work on arterial or collector streets is performed, the Contractor shall schedule the work with the Engineer to minimize disruption to the flow of traffic.

The Contractor shall provide a list of three (3) persons who can be called on a 24-hour basis to handle barricading or other problems relating to the construction activity.

**This project may involve work on or adjacent to arterial roadways carrying high traffic volumes. Weekday construction activity must be limited to only the hours between 9:00 am and 3:00 pm on this facility in order to avoid the peak rush hours.** During the work operation, a minimum of one lane of traffic must be maintained in each direction at all times. All lane closures must be approved by the Street Foreman in advance. Appropriate lane closures with arrow boards and signs are required regardless of duration of the lane reduction.

The emergency response persons shall be capable of responding within one (1) hour after notification by the City. If there has been no response within one hour after notification, the City will respond at a cost of \$400.00 per hour (two men plus truck) with a minimum charge for two hours, plus materials. This charge will be deducted from payments to the Contractor.

The Contractor shall also furnish, place and maintain traffic cones, one (1) for every 15 m (50') for each lane being worked on; barricades with arrows, four (4) for each intersection being worked on; signs, if applicable, approximately 910 mm X 910 mm (36" x 36") stating in bold letters, "KEEP OFF - CRACKFILLING," to be placed strategically to keep traffic off the newly placed crackfiller, flag trees, one (1) for each end of the street being worked on; and adequate signs, barricades and cones to direct and control traffic to the proper travel lanes, one (1) set at each end of the street being worked on. The Contractor shall maintain two (2) directions of traffic during the performance of work covered by the contract.

Traffic control shall include furnishing, setting up, performing, maintaining, and removing traffic control and for all equipment, tools and labor necessary to complete the work in accordance with this contract and will be paid for at the contract unit price.

2025 CRACK/JOINT SEALING LOCATIONS

| STREET          | LIMITS                    | LENGTH X WIDTH | COMPLETED |
|-----------------|---------------------------|----------------|-----------|
| Orchard         | Oakton to Forest          | 1333 x 24      |           |
| Jarvis          | Wolf to Oxford            | 2543 x 24      |           |
| Oxford          | Jarvis to Cul-De-Sac      | 821 x 28       |           |
| Jarvis          | Wolf to Eastview          | 953 x 28       |           |
| Beau            | Golf to Sandy             | 1325 x 24      |           |
| Bradley         | Dulles to Little Path     | 1577 x 24      |           |
| Bradley Court   | Bradley to Cul-De-Sac     | 148 x 24       |           |
| Columbia        | Wolf West to Dead-End     | 335 x 24       |           |
| Debra           | Beau to Lillian           | 1139 x 24      |           |
| Kolpin          | Algonquin to Elizabeth    | 1191 x 26      |           |
| Santa Rosa      | Wolf to West Dead-End     | 757 x 30       |           |
| Spruance        | King to Walnut            | 725 x 24       |           |
| Westmere        | Lillian to Beau           | 1211 x 24      |           |
| Howard          | Wolf to Mt Propsect Rd    | 3112 x 40      |           |
| Hewitt          | Algonquin to Florian      | 1021 x 24      |           |
| Tures           | Plainfield to Nebel       | 810 x 24       |           |
| Nebel           | Plainfield to Tures       | 499 x 24       |           |
| Leahy Circle    | Kathleen to Millers       | 995 x 26       |           |
| First Ave       | Prairie to North          | 1748 x 24      |           |
| Fourth Ave      | Thacker to North          | 2845 x 24      |           |
| Morse           | Scott to Joseph           | 22x400         |           |
| Rusty           | Parkwood to Estes         | 30x600         |           |
| Scott           | Sunset to Pratt           | 28x1935        |           |
| Northshore      | Eisenhower to Curtis      | 22x916         |           |
| Prospect In     | Lee to Dexter             | 22x1020        |           |
| Jarvis          | Cedar to Magnolia         | 26x620         |           |
| Jarlath         | West End to Douglas       | 26x500         |           |
| Grove           | Woodland to North End     | 30x1020        |           |
| Fargo           | Cedar to River            | 30x965         |           |
| Everett         | Dexter to Lee             | 22x1020        |           |
| Dexter          | Propsect to Everett       | 22x640         |           |
| Southwest Place | West Grant to West Villa  | 28x290         |           |
| Peter           | Laura to Estes            | 24x640         |           |
| Oxford          | Oakton to Forest          | 26x1270        |           |
| Orchard         | Wicke to Forest           | 28x430         |           |
| Northwest Place | West Grant to Thacker     | 38x480         |           |
| Northeast Place | East Grant to Thacker     | 38x480         |           |
| Lincoln         | Oxford to Wolf            | 24x904         |           |
| Forest          | West Dead End to River Rd | 24x3450        |           |
| Estes           | Peter to West End         | 22x250         |           |
| Northwest Pl    | W.Grant to West Villa     | 28x290         |           |
| Grant dr West   | Southeast to Northwest    | 28x548         |           |
| Good            | Ballard to Church         | 24x1170        |           |
| Acres           | Miner to Dead End         | 22x900         |           |
| Cornell         | State to Princeton        | 30x2120        |           |

|               |                              |          |
|---------------|------------------------------|----------|
| Cambridge     | Wisconsin to Miner           | 26x3125  |
| Ardmore       | Stratford to Stratford       | 30x1820  |
| Villa dr West | Southeast to Northwest PL    | 28x1500  |
| First ave     | Dempster to Prairie          | 36x660   |
| Campbell      | River to Center              | 26x3150  |
| Webster       | Oakton to Forest             | 26x1290  |
| Spruce        | Highland to Dead End         | 20x103   |
| Sixth         | Oakwood to Walnut            | 26x1900  |
| Curtis        | Pratt to Dead End            | 28x950   |
| Courtesy      | Marshall to Dover            | 24x880   |
| Ashland       | Cora to River                | 26x1120  |
| Roxbury       | Mt Prospect to Danbury       | 32x140   |
| Roxbury       | Danbury to Pennsylvania      | 26x1420  |
| Polynesian    | Fourth to Seventh            | 24x886   |
| Patton        | Devon to Craig               | 24x1290  |
| Orchard       | Wicke to Riverview           | 22x1510  |
| Hoffman       | Wolf to West Villa           | 30x940   |
| Harding       | Graceland to Lee             | 24x930   |
| Fifth ave     | Rand to Polynesian           | 24x1700  |
| Shagbark      | River to South Dead End      | 24x590   |
| Scott         | Jarvis to Touhy              | 22x1280  |
| Fox           | Joseph to Craig              | 22x690   |
| Fifth ave     | Forest to Oakton             | 30x1288  |
| Cedar         | Touhy to Jarvis              | 22x1280  |
| Birch         | Howard to Welwyn             | 22x774   |
| Sprucewood    | Birchwood to Jarlath         | 24x1778  |
| Walnut ct     | Southwest Place to Dead End  | 26x460   |
| Stratford     | State to Princeton           | 26x2034  |
| Grant         | Southeast PL to Northeast PL | 24x1764  |
| Wolf rd       | Rand Rd to Central           | 60x 1550 |
| Westmere      | Farthing to Easy             | 22x915   |
| Welwyn        | Cedar to Maple               | 26x960   |
| Morse         | Scott to Eisenhower          | 26x590   |
| Leslie        | Jill to Algonquin            | 24x505   |
| Grove         | Rand to Woodland             | 22x1180  |
| Fifth         | Prairie to Thacker           | 20x656   |
| Fargo         | Chestnut to Lee              | 30x290   |
| Beau          | Dempster to Lance            | 24x470   |
| Westview      | Touhy to Jarvis              | 26x1270  |
| Spruce        | Mannheim to Propsect         | 28x1070  |
| David         | Jospeh and Rusty             | 24x960   |
| Chestnut      | Howard to Dead End           | 26x1746  |
| Patricia ln   | Central to Berkshire         | 24x614   |
| Elizabeth     | Devonshire to Susan          | 28x963   |
| Brentwood     | Dulles to East end           | 24x1209  |
| Walnut ct     | Southeast Place to Third     | 22x300   |
| Villa dr east | Southeast PL to Northwest PL | 26x1500  |

|               |                               |         |
|---------------|-------------------------------|---------|
| Third ave     | Wayne to Algonquin            | 24x450  |
| Thacker       | Lee to Graceland              | 36x414  |
| Stockton      | Koehler to Sheperd            | 24x750  |
| Plainfield    | Howard to Everett             | 24x1308 |
| Lyman         | Lechner to Church             | 22x434  |
| Lyman         | Prairie to Dempster           | 24x590  |
| Jill          | Leslie to Andrea              | 24x820  |
| Lasalle       | Millers to Bradley            | 24x725  |
| Eisenhower    | Morse to Laura                | 26x590  |
| Westgate      | Millers to Washington         | 24x1416 |
| Sycamore      | Riverview to Everett          | 26x630  |
| Simone        | Tracy to Jon                  | 26x700  |
| Lawn ln       | Dulles to Norman              | 22x800  |
| Lance         | Beau to marshall              | 22x1506 |
| Estes         | Greco to Maple                | 24x1390 |
| Beau          | Dulles to Debra               | 28x320  |
| Anderson Terr | King to Walnut                | 22x810  |
| Westmere      | Lillian to Bell               | 24x2580 |
| Thacker       | First to Gracleand            | 36x770  |
| Thacker       | Cora to River Road            | 40x1090 |
| Marshall      | Kathleen to Dempster          | 30x774  |
| Hoffman Pkwy  | West Villa to Third Ave       | 24x978  |
| Dennis pl     | Forest to Heather             | 24x280  |
| Bradley       | Dulles to East End            | 26x1460 |
| Princeton     | Wolf Road to Eighth Ave       | 26x285  |
| Millers       | Mt Prospect Rd to LaSalle     | 28x1250 |
| Mill st       | River to East End             | 22x540  |
| Lunt          | Maple to Greco                | 24x1160 |
| Deane St      | VanBuren to Algonquin         | 24x288  |
| Woodland      | River to East End             | 26x1050 |
| Sandy         | Lillian to Beau               | 22x1220 |
| Mark ave      | Wolf to Madelyn               | 24x1120 |
| Greco         | Pratt to Farwell              | 22x420  |
| Beau dr       | Sandy to Debra                | 24x630  |
| Sunset        | Stillwell to Scott            | 30x690  |
| South         | Sunset to North End           | 24x116  |
| Second        | Golf Rd to S. Golf-Cul-De-Sac | 22x180  |
| Princeton     | Radcliffe to Cambridge        | 24x1320 |
| Pearle        | David to Fox                  | 24x815  |
| Northeast Pl  | E. Grant to E. Villa          | 26x300  |
| Locust        | Everett to South End          | 26x770  |
| Joseph        | David to Fox                  | 24x820  |
| Heather       | Kingston and Kingston         | 26x1160 |
| Craig         | Patton to Pratt               | 26x1400 |



**PUBLIC WORKS AND  
ENGINEERING DEPARTMENT**

1111 Joseph J. Schwab Road  
Des Plaines, IL 60016  
P: 847.391.5464  
desplainesil.gov

**MEMORANDUM**

Date: April 23, 2026

To: Dorothy Wisniewski, City Manager

From: Jason Ostrowski, Superintendent 

Cc: Timothy Watkins, Director of Public Works and Engineering  
Thomas Bueser, Assistant Director of Public Works

Subject: 2026 Streetlight LED Upgrades

---

**Issue:** The approved 2026 budget includes funds for Streetlight upgrades to LED fixtures.

**Analysis:** The Public Works and Engineering Department annually conducts street light maintenance and has identified Oakton Street from Spruce Avenue to just east of River Road and River Road from 1518 S. River Road to 1670 S. River Road as locations which would benefit from LED streetlight upgrades. This energy efficiency upgrade would reduce the wattage that is currently used for these forty-six streetlights from 21,390 watts to 9,476 watts. H&H Electric Company, the City's current streetlight maintenance and repair contractor, has submitted a proposal to furnish and install forty-six new LED fixtures in the amount of \$59,163.26. Staff has applied for and received an incentive from the ComEd Energy Efficiency Program for this project in the amount of \$17,871.00.

**Recommendation:** In the best interest of the City, we recommend waiving the competitive bidding process and approving the proposal for the 2026 Streetlight LED Upgrades with H&H Electric, 2830 Commerce St, Franklin Park, IL, 60131, per the submitted proposal in the not to exceed amount of \$59,163.26. Funding for this project will be the Street Maintenance, Miscellaneous Contractual Services account (100-50-530-0000.6195).

**Attachments:**

Attachment 1 - H&H Electric Co. Proposal  
Attachment 2 - Com Ed Funds Reservation Letter  
Resolution R-120-26



2830 COMMERCE STREET,  
FRANKLIN PARK, ILLINOIS 60131-2927  
OFFICE PHONE: (708) 453-2222 / FACSIMILE: (708) 453-2851.

**H&H JOB #:** N/A

**IDOT ITEM #:** N/A

**DBE %:** 0.00%

**ADDENDUM:** N/A

**LOCATION / DESCRIPTION:** CITY OF DES PLAINES - OAKTON ST. FROM SPRUCE AVE. TO DES PLAINES RIVER RD. - UPGRADE EXISTING FIXTURES TO L.E.D..

**CONTRACT #:** N/A

**COUNTY:** COOK

**PROJECT #:** N/A

**JOB #:** N/A

**SECTION #:** N/A

**ROUTE:** OAKTON ST.

**DATE:** Thursday, February 19, 2026

**BID AS:** GENERAL ELECTRICAL CONTRACTOR

**BID DUE DATE:** N/A

**BID DUE TIME:** N/A

**BID LOCATION:** EMAIL TO JASON OSTROWSKI AT THE CITY OF DES PLAINES - [Jostrowski@desplainesil.gov](mailto:Jostrowski@desplainesil.gov)

**DUE TO OWNER (DATE):** N/A

**DUE TO OWNER (TIME):** N/A

**COMPLETION:** TO BE DETERMINED

| ITEM NUMBER   | PAY ITEM DESCRIPTION  | UNIT OF MEASURE | QUANTITY | UNIT PRICE | TOTAL PRICE      |
|---------------|---|-----------------|----------|------------|------------------|
| 1             | REMOVE EXISTING FIXTURES AND DELIVER TO PUBLIC WORKS. FURNISH AND INSTALL (46) LEOTEK LED FIXTURES WITH SHORTING CAPS - (PART # GCL2-80J-MV-50K-2R-GY-295). | L SUM           | 1.000    | 59,163.26  | 59,163.26        |
| <b>TOTALS</b> |   |                 |          |            | <b>59,163.26</b> |

| ITEM NUMBER   | PAY ITEM DESCRIPTION  | UNIT OF MEASURE | QUANTITY | UNIT PRICE | TOTAL PRICE |
|---------------|---|-----------------|----------|------------|-------------|
| <b>NOTES:</b> |   |                 |          |            |             |
| 1             | ALL WORK TO BE COMPLETED PURSUANT TO THE CURRENT CONTRACT PRICING.  |                 |          |            |             |
| 2             | THIS PROPOSAL IS BASED ON NORMAL WORKING HOURS.   |                 |          |            |             |
|               | <b>NOT INCLUDED IN THIS PROPOSAL:</b>   |                 |          |            |             |
| 1             | ALL FINAL LANDSCAPE RESTORATION. ANY EXCEPTIONS ARE NOTED ABOVE.  |                 |          |            |             |
| 2             | SPECIAL INSURANCE, FEES, OR PERMITS OF ANY TYPE.  |                 |          |            |             |
| 3             | BONDS, ALTHOUGH WE ARE BONDABLE.  |                 |          |            |             |
| 4             | NO WORK WILL BE DONE OTHER THAN THE ITEMS ON OUR BID WITHOUT WRITTEN APPROVAL.  |                 |          |            |             |
| 5             | PROJECT LAYOUT INCLUDING GRADES AND ELEVATIONS.   |                 |          |            |             |
| 6             | ANY AND ALL COSTS CONTRIBUTABLE TO TESTING, DOCUMENTATION, REMOVAL AND/OR DISPOSAL OF ANY SPOILS.                                   |                 |          |            |             |
| 7             | ANY MAJOR SUBSURFACE OBSTACLES ENCOUNTERED WHICH CAUSES A DECREASE IN OUR PRODUCTION SHALL BE COMPENSATED AT TIME & MATERIAL RATES. |                 |          |            |             |
| 8             | HARD SURFACE REMOVAL & REPLACEMENT.   |                 |          |            |             |
| 9             | ROCK EXCAVATION.  |                 |          |            |             |
| 10            | PROPOSAL VALID FOR <b>60</b> DAYS.  |                 |          |            |             |

4/6/2026

City of Des Plaines  
Various  
Des Plaines, IL 60018  
Re: Project LDSB-1208

Dear Jason Ostrowski,

We are pleased to inform you that the ComEd Energy Efficiency Program has received your application for Project # LDSB-1208 – City of Des Plaines.

We have reserved \$11,914.00 + \$5,957.00 (2026 Bonuses) of incentives for this project based on the following description. Total incentives \$17,871.00 if applicable:

| Measures       | Quantity |
|----------------|----------|
| Streetlighting | 46       |

Reserved funds will expire on **6/29/2026**, unless you request a one-time extension before the expiration date. Failure to submit a complete final application or request an extension may result in your project being canceled. Reserved funds may not be transferred to other projects, facilities, or customers.

Please note that a reservation does not guarantee an incentive.

- The amount reserved includes an incentive plus any estimated 2026 additional incentives that you may have applied for, but this does not guarantee the payment of any incentive.
- The final incentive amount paid, including any eligible 2026 additional incentives, will be based on our review of your final application and supporting documentation of equipment installed.
- Incentive amounts are subject to 2026 program year incentive rates, specifications, and requirements.

Your installed equipment must meet the required specifications and comply with all terms and conditions.<sup>1</sup> Equipment specifications and program terms and conditions are found in the application and incentive worksheets available at [ComEd.com/BizIncentives](https://www.comed.com/BizIncentives).

To expedite final application processing, please submit all supporting documentation specified in the application and incentive worksheet(s).

---

<sup>1</sup> All replaced equipment must be recycled/disposed of according to state, federal and local regulations. Information about State of Illinois requirements can be found at the Illinois Environmental Protection Agency website: [https://www2.illinois.gov/epa/general\\_information/Pages/land-pollution-and-waste-disposal.aspx](https://www2.illinois.gov/epa/general_information/Pages/land-pollution-and-waste-disposal.aspx)

## Looking for Some Instant Savings?

ComEd also offers instant discounts at the time of purchase on qualified lighting, HVAC and battery charger products that are sold through participating distributors. Visit [ComEd.com/InstantDiscounts](https://www.comed.com/InstantDiscounts) to learn more!

## Why Does ComEd Provide These Incentive Funds?

These incentives are intended to assist ComEd customers in saving energy by completing energy efficiency projects they would not have pursued without the extra financial assistance. Funding for the ComEd Energy Efficiency Program and all related offerings comes from ComEd customers in accordance with state law. The goal of the ComEd Energy Efficiency Program is to maximize the benefits of rate payer funds in a cost-effective manner.

As required by law, an independent third-party evaluator, Guidehouse, reviews all program offerings. This is done through program level analysis, random sampling of specific projects and direct customer interviews to determine incentive impact. The independent evaluator verifies that the sampled offering or project:

- Met all program requirements;
- Saved energy as claimed in the applications; and
- Was influenced by the incentive

The findings of the independent evaluator do not impact the current customer or the current project in any way, but they may influence how the program will be designed and implemented in the future. Your responses to the independent evaluator will be helpful in determining whether any future program changes are needed.

We appreciate your participation in our program and the efforts your organization is undertaking to save energy. If you have questions, please call us at (855) 433-2700 or email us at [BusinessEE@ComEd.com](mailto:BusinessEE@ComEd.com).

Sincerely,

**ComEd Energy Efficiency Program Team**

CITY OF DES PLAINES

RESOLUTION R - 120 - 26

**A RESOLUTION APPROVING THE PROCUREMENT OF  
2026 LED STREETLIGHT UPGRADES FROM H&H  
ELECTRIC COMPANY.**

**WHEREAS**, Article VII, Section 10 of the 1970 Illinois Constitution authorizes the City to contract with individuals, associations, and corporations in any manner not prohibited by law or ordinance; and

**WHEREAS**, the City has appropriated funds in the Miscellaneous Contractual Services Fund to procure LED streetlight upgrades, including but not limited to, removal of old fixtures and installation of new LED fixtures ("*Work*"); and

**WHEREAS**, the City requested a proposal from H&H Electric Company ("*Contractor*") which is the City's current streetlight maintenance and repair contractor; and

**WHEREAS**, Contractor submitted a proposal in the total not-to-exceed amount of \$59,163.26 for the performance of the Work; and

**WHEREAS**, the City desires to procure the performance of the Work from Contractor in the not-to-exceed amount of \$59,163.26; and

**WHEREAS**, the City Council has determined that it is in the best interest of the City to waive the competitive bidding requirements in the City Code and procure the Work from Contractor;

**NOW, THEREFORE, BE IT RESOLVED** by the City Council of the City of Des Plaines, Cook County, Illinois, in the exercise of its home rule powers, as follows:

**SECTION 1: RECITALS.** The foregoing recitals are incorporated into, and made a part of, this Resolution as findings of the City Council.

**SECTION 2: WAIVER OF COMPETITIVE BIDDING.** The requirement that competitive bids be solicited for the procurement of the Work is hereby waived.

**SECTION 3: APPROVAL OF PURCHASE.** The City Council hereby approves the procurement by the City of the Work from Contractor in the total not-to-exceed amount of \$59,163.26.

**SECTION 4: AUTHORIZATION OF PURCHASE.** The City Council authorizes and directs the City Manager and the City Clerk to execute and seal such documents approved by the General Counsel, and the City Manager to make payments, on behalf of the City, as are necessary to procure the Work from Contractor in a total not-to-exceed amount of \$59,163.26.

**SECTION 5: EFFECTIVE DATE.** This Resolution shall be in full force and effect from and after its passage and approval according to law.

**PASSED** this \_\_\_ day of \_\_\_\_\_, 2026.

**APPROVED** this \_\_\_ day of \_\_\_\_\_, 2026.

**VOTE:** AYES \_\_\_\_\_ NAYS \_\_\_\_\_ ABSENT \_\_\_\_\_

\_\_\_\_\_  
**MAYOR**

ATTEST:

Approved as to form:

\_\_\_\_\_  
**CITY CLERK**

\_\_\_\_\_  
**Peter M. Friedman, General Counsel**

DP-Resolution Waive Bid for LED Streetlight Upgrades from H&H Electric Company



**PUBLIC WORKS AND  
ENGINEERING DEPARTMENT**

1111 Joseph J. Schwab Road  
Des Plaines, IL 60016  
P: 847.391.5464  
desplainesil.gov

**MEMORANDUM**

Date: April 23, 2026

To: Dorothy Wisniewski, City Manager

From: Jason Ostrowski, Superintendent 

Cc: Timothy Watkins, Director of Public Works and Engineering  
Thomas Bueser, Assistant Director of Public Works

Subject: Bid Award – 2026 Brick Paver Repairs

**Issue:** The 2026 budget includes funds for downtown brick paver repairs. Three bids for these repairs were received and opened on April 9, 2026.

**Analysis:** The Public Works and Engineering Department annually conducts an evaluation of brick paver conditions and determines the locations most suitable for repair maintenance. The Public Works Department also makes utility repairs throughout the year that may require the removal of bricks that need to be replaced. The bid scope requires vendors to provide base pricing. The bid summary is listed below:

| <b>Company</b>          | <b>Total Amount</b> |
|-------------------------|---------------------|
| GC Designs, Inc.        | \$44,750.00         |
| C.R. Schmidt, Inc.      | \$56,750.00         |
| Copenhaver Construction | \$76,500.00         |

Of the three bids received, GC Designs Inc. provided the lowest unit pricing, however, they did not meet the responsible bidders ordinance. C.R. Schmidt, Inc. submitted the next lowest unit pricing and have successfully completed work for the City through past CIP programs in 2023, 2024 and 2025. C.R Schmidt, Inc. has also completed projects for Skokie and Bedford Park with positive results along with being on IDOT’s approved contractors list.

**Recommendation:** We recommend rejecting GC Designs Inc.'s bid and awarding the 2026 Brick Paver Repairs contract to C.R. Schmidt, Inc., 3S215 Talbot Avenue, Warrenville, IL, 60555, in the not to exceed amount of \$125,000.00. Source of funding for this contract will be the Street Maintenance Fund account (100-50-530-0000.6195) and Facilities and Grounds Maintenance Fund account (100-50-535-6315.007).

**Attachments:**  
Resolution R-121-26  
Exhibit A – Contract

**CITY OF DES PLAINES**

**RESOLUTION R - 121 - 26**

**A RESOLUTION APPROVING AN AGREEMENT WITH  
C.R. SCHMIDT, INC., FOR THE 2026 BRICK PAVER  
REPAIRS.**

**WHEREAS**, Article VII, Section 10 of the 1970 Illinois Constitution authorizes the City to contract with individuals, associations, and corporations in any manner not prohibited by law or ordinance; and

**WHEREAS**, the City has appropriated funds in the Street Maintenance Fund and Facilities and Grounds Maintenance Fund for use by the Public Works and Engineering Department during the 2026 fiscal year for brick paver repairs in various locations throughout the City ("*Work*"); and

**WHEREAS**, pursuant to Chapter 10 of Title 1 of the of the City of Des Plaines City Code and the City's purchasing policy, the City solicited bids for the procurement of the Work; and

**WHEREAS**, the City received three bids, which were opened on April 9, 2026; and

**WHEREAS**, C.R. Schmidt, Inc. ("*Vendor*") submitted the lowest responsible bid for the Work in an amount not to exceed amount of \$125,000.00; and

**WHEREAS**, the City desires to enter into an agreement with Vendor for the Work at the price proposed ("*Agreement*"); and

**WHEREAS**, the City Council has determined that it is in the best interest of the City to enter into the Agreement with Vendor for the Work;

**NOW, THEREFORE, BE IT RESOLVED** by the City Council of the City of Des Plaines, Cook County, Illinois, in the exercise of its home rule powers, as follows:

**SECTION 1: RECITALS.** The foregoing recitals are incorporated into, and made a part of, this Resolution as findings of the City Council.

**SECTION 2: APPROVAL OF AGREEMENT.** The City Council hereby approves the Agreement in substantially the form attached to this Resolution as **Exhibit A**, and in a final form to be approved by the General Counsel.

**SECTION 3: EXECUTION OF AGREEMENT.** The City Council hereby authorizes and directs the City Manager to execute, and the City Clerk to seal, on behalf of the City, the final Agreement.

**SECTION 4: EFFECTIVE DATE.** This Resolution shall be in full force and effect from and after its passage and approval according to law.

**PASSED** this \_\_\_\_ day of \_\_\_\_\_, 2026.

**APPROVED** this \_\_\_\_ day of \_\_\_\_\_, 2026.

**VOTE:** AYES \_\_\_\_ NAYS \_\_\_\_ ABSENT \_\_\_\_

\_\_\_\_\_  
**MAYOR**

ATTEST:

Approved as to form:

\_\_\_\_\_  
**CITY CLERK**

\_\_\_\_\_  
**Peter M. Friedman, General Counsel**

DP - Resolution Approving Agreement with GC Designs Inc., for 2026 Brick Paver Repairs

CITY OF DES PLAINES

CONTRACT FOR

2026 Brick Paver Repairs

Full Name of Bidder C.R. Schmidt, Inc. ("Bidder")
Principal Office Address 3S215 Talbot Ave., Warrenville, IL 60555
Local Office Address
Contact Person Olivia Lockett Telephone Number 630-293-5885

1. Work Proposal

A. Contract and Work. If this Contract is accepted, Bidder proposes and agrees that Bidder shall, at its sole cost and expense, provide, perform, and complete, in the manner specified and described, and upon the terms and conditions set forth, in this Contract and Owner's written notification of acceptance in the form included in this bound set of documents, all of the following, all of which is herein referred to as the "Work":

- 1. Labor, Equipment, Materials and Supplies. Provide, perform, and complete, in the manner specified and described in this Contract/Proposal, all necessary work, labor, services, transportation, equipment, materials, supplies, information, data, and other means and items necessary for the 2026 Brick Paver Repairs located at various locations throughout the City (the "Work Site");
2. Permits. Procure and furnish all permits, licenses, and other governmental approvals and authorizations necessary in connection therewith;
3. Bonds and Insurance. Procure and furnish all bonds and all insurance certificates and policies of insurance specified in this Contract;
4. Taxes. Pay all applicable federal, state, and local taxes;
5. Miscellaneous. Do all other things required of Bidder by this Contract; and
6. Quality. Provide, perform, and complete all of the foregoing in a proper and workmanlike manner, consistent with highest standards of professional and construction practices, in full compliance with, and as required by or pursuant, to this Contract, and with the greatest economy, efficiency, and expedition consistent therewith, with only new, undamaged, and first quality equipment, materials, and supplies.

B. Performance Standards. If this Contract is accepted, Bidder proposes and agrees that all Work shall be fully provided, performed, and completed in accordance with the specifications attached hereto in Attachment A and by this reference made a part of this Contract. No provision of any referenced standard, specification, manual or code shall change the duties and responsibilities of Owner or Bidder from those set forth in this Contract. Whenever any equipment, materials, or supplies are

{00119453.2}

specified or described in this Contract by using the name or other identifying feature of a proprietary product or the name or other identifying feature of a particular manufacturer or vendor, the specific item mentioned shall be understood as establishing the type, function, and quality desired. Other manufacturers' or vendors' products may be accepted, provided that the products proposed are equivalent in substance and function to those named as determined by Owner in its sole and absolute discretion.

C. Responsibility for Damage or Loss. If this Contract is accepted, Bidder proposes and agrees that Bidder shall be responsible and liable for, and shall promptly and without charge to Owner repair or replace, damage done to, and any loss or injury suffered by, Owner, the Work, the Work Site, or other property or persons as a result of the Work.

D. Inspection/Testing/Rejection. Owner shall have the right to inspect all or any part of the Work and to reject all or any part of the Work that is, in Owner's judgment, defective or damaged or that in any way fails to conform strictly to the requirements of this Contract and Owner, without limiting its other rights or remedies, may require correction or replacement at Bidder's cost, perform or have performed all Work necessary to complete or correct all or any part of the Work that is defective, damaged, or nonconforming and charge Bidder with any excess cost incurred thereby, or cancel all or any part of any order or this Contract. Work so rejected may be returned or held at Bidder's expense and risk.

2. Contract Price Proposal

If this Contract is accepted, Bidder proposes, and agrees, that Bidder shall take in full payment for all Work and other matters set forth under Section 1 above, including overhead and profit; taxes, contributions, and premiums; and compensation to all subcontractors and suppliers, the compensation set forth below.

A. Schedule of Prices. For providing, performing, and completing all Work, the total Base Bid Contract Price of:

\$ 56,750.00

B. Basis for Determining Prices. It is expressly understood and agreed that:

- 1. All prices stated in the Schedule of Prices are firm and shall not be subject to escalation or change;
2. Owner is not subject to state or local sales, use, and excise taxes, that no such taxes are included in the Schedule of Prices, and that all claim or right to claim

any additional compensation by reason of the payment of any such tax is hereby waived and released; and

3. All other applicable federal, state, and local taxes of every kind and nature applicable to the Work are included in the Schedule of Prices.
4. The approximate quantities set forth in the Schedule of Prices for each Unit Price Item are Owner's estimate only, that Owner reserves the right to increase or decrease such quantities, that payment for each Unit Price Item shall be made only on the actual number of acceptable units of such Unit Price Item installed complete in place in full compliance with this Contract/Proposal, and that all claim or right to dispute or complain of any such estimated quantity, or to assert that there was any misunderstanding in regard to the nature or amount of any Unit Price Item to be provided or performed, is hereby waived and released; and
5. Any items of Work not specifically listed or referred to in the Schedule of Prices, or not specifically included for payment under any Unit Price Item, shall be deemed incidental to the Contract Price, shall not be measured for payment, and shall not be paid for separately except as incidental to the Contract Price, including without limitation extraordinary equipment repair, the cost of transportation, packing, cartage, and containers, the cost of preparing schedules and submittals, the cost or rental of small tools or buildings, the cost of utilities and sanitary conveniences, and any portion of the time of Bidder, its superintendents, or its office and engineering staff.]

C. Time of Payment. It is expressly understood and agreed that all payments shall be made in accordance with the following schedule:

Bidder will invoice Owner for all Work completed, and Owner will pay Bidder all undisputed amounts no later than 45 days after receipt by Owner of each invoice.

All payments may be subject to deduction or setoff by reason of any failure of Bidder to perform under this Contract/Proposal. Each payment shall include Bidder's certification of the value of, and partial or final waivers of lien covering, all Work for which payment is then requested and Bidder's certification that all prior payments have been properly applied to the payment or reimbursement of the costs with respect to which they were paid.

All payments may be subject to deduction or setoff by reason of any failure of Bidder to perform under this Contract/Proposal. Each payment shall include Bidder's certification of the value of, and partial or final waivers of lien covering, all Work for which payment is then requested and Bidder's certification that all prior payments have been properly applied to the payment or reimbursement of the costs with respect to which they were paid.

### 3. Contract Time

If this Contract is accepted, Bidder proposes and agrees that Bidder shall commence the Work within 10 days after

Owner's acceptance of the Contract provided Bidder shall have furnished to Owner insurance certificates and policies of insurance specified in this Contract (the "Commencement Date"). If this Contract is accepted, Bidder proposes and agrees that Bidder shall perform the Work diligently and continuously and shall complete the Work no later than August 31, 2026 (the "Completion Date").

### 4. Financial Assurance

A. Insurance. If this Contract is accepted, Bidder proposes and agrees that Bidder shall provide certificates of insurance evidencing the minimum insurance coverage and limits set forth below within 10 days after Owner's acceptance of this Contract. Such insurance shall be in form, and from companies, acceptable to Owner and shall name Owner, including its Council members and elected and appointed officials, its officers, employees, agents, attorneys, consultants, and representatives, as an Additional Insured. The insurance coverage and limits set forth below shall be deemed to be minimum coverage and limits and shall not be construed in any way as a limitation on Bidder's duty to carry adequate insurance or on Bidder's liability for losses or damages under this Contract. The minimum insurance coverage and limits that shall be maintained at all times while providing, performing, or completing the Work are as follows:

#### 1. Workers' Compensation and Employer's Liability

Limits shall not be less than:

Worker's Compensation: Statutory

Employer's Liability: \$500,000 each accident-injury; \$500,000 each employee-disease; \$500,000 disease-policy.

Such insurance shall evidence that coverage applies to the State of Illinois and provide a waiver of subrogation in favor of Owner.

#### 2. Commercial Motor Vehicle Liability

Limits for vehicles owned, non-owned or rented shall not be less than:

\$1,000,000 Bodily Injury and Property Damage Combined Single Limit

#### 3. Commercial General Liability

Limits shall not be less than:

\$1,000,000 Bodily Injury and Property Damage Combined Single Limit.

Coverage is to be written on an "occurrence" basis. Coverage to include:

- Premises Operations
- Products/Completed Operations
- Independent Contractors

{00119453.2}

- Personal Injury (with Employment Exclusion deleted)
- Broad Form Property Damage Endorsement
- "X," "C," and "U"
- Contractual Liability

Contractual Liability coverage shall specifically include the indemnification set forth below.

4. **Umbrella Liability**

Limits shall not be less than:

\$2,000,000 Bodily Injury and Property Damage Combined Single Limit.

This Coverage shall apply in excess of the limits stated in 1, 2, and 3 above.

C. **Indemnification.** If this Contract is accepted, Bidder proposes and agrees that Bidder shall indemnify, save harmless, and defend Owner against all damages, liability, claims, losses, and expenses (including attorneys' fees) that may arise, or be alleged to have arisen, out of or in connection with Bidder's performance of, or failure to perform, the Work or any part thereof, or any failure to meet the representations and warranties set forth in Section 6 of this Contract.

D. **Penalties.** If this Contract is accepted, Bidder proposes and agrees that Bidder shall be solely liable for any fines or civil penalties that are imposed by any governmental or quasi-governmental agency or body that may arise, or be alleged to have arisen, out of or in connection with Bidder's performance of, or failure to perform, the Work or any part thereof.

5. **Firm Contract**

All prices and other terms stated in this Contract are firm and shall not be subject to withdrawal, escalation, or change provided Owner accepts this Contract within 45 days after the date the bidder's contract proposal is opened.

6. **Bidder's Representations and Warranties**

To induce Owner to accept this Contract, Bidder hereby represents and warrants as follows:

A. **The Work.** The Work, and all of its components, (1) shall be of merchantable quality; (2) shall be free from any latent or patent defects and flaws in workmanship, materials, and design; (3) shall strictly conform to the requirements of this Contract, including without limitation the performance standards set forth in Section 1B of this Contract; and (4) shall be fit, sufficient, and suitable for the purposes expressed in, or reasonably inferred from, this Contract and the warranties expressed herein shall be in addition to any other warranties expressed or implied by law, which are hereby reserved unto Owner. Bidder, promptly and without charge, shall correct any failure to fulfill the above warranty at any time within two years after final payment or such longer period as may be prescribed in the performance standards set forth in Section 1B of this Contract or by law. The above warranty shall be extended automatically to cover all repaired and replacement parts and labor provided or performed under such warranty and Bidder's

obligation to correct Work shall be extended for a period of two years from the date of such repair or replacement. The time period established in this Section 6A relates only to the specific obligation of Bidder to correct Work and shall not be construed to establish a period of limitation with respect to other obligations that Bidder has under this Contract.

B. **Compliance with Laws.** The Work, and all of its components, shall be provided, performed, and completed in compliance with, and Bidder agrees to be bound by, all applicable federal, state, and local laws, orders, rules, and regulations, as they may be modified or amended from time to time, including without limitation the Illinois Prevailing Wage Act, 820 ILCS 130/0.01 et seq. and any other prevailing wage laws; any statutes requiring preference to laborers of specified classes; the Illinois Steel Products Procurement Act, 30 ILCS 565/1 et seq.; any statutes prohibiting discrimination because of, or requiring affirmative action based on, race, creed, color, national origin, age, sex, or other prohibited classification; the Employment of Illinois Workers on Public Works Act, 30 ILCS 570/0.01 et seq.; and any statutes regarding safety or the performance of the Work.

C. **Prevailing Wage Act.** This Contract calls for the construction of a "public work," within the meaning of the Illinois Prevailing Wage Act, 820 ILCS 130/0.01 et seq. (the "Act"). If the Illinois Department of Labor revises the prevailing rate of hourly wages to be paid, the revised rate will apply to this Contract. Bidder and any subcontractors rendering services under this Contract must comply with all requirements of the Act, including but not limited to, all wage, notice, and record-keeping duties and certified payrolls.

D. **Not Barred.** Bidder is not barred by law from contracting with Owner or with any other unit of state or local government as a result of (i) a violation of either Section 33E-3 or Section 33E-4 of Article 33 of the Criminal Code of 1961, 720 ILCS 5/33E-1 et seq.; or (ii) a violation of the USA Patriot Act of 2001, 107 Public Law 56 (October 26, 2001) (the "Patriot Act") or other statutes, orders, rules, and regulations of the United States government and its various executive departments, agencies and offices related to the subject matter of the Patriot Act, including, but not limited to, Executive Order 13224 effective September 24, 2001. Bidder is not acting, directly or indirectly, for or on behalf of any person, group, entity or nation named by the United States Treasury Department as a Specially Designated National and Blocked Person, or for or on behalf of any person, group, entity or nation designated in Presidential Executive Order 13224 as a person who commits, threatens to commit, or supports terrorism; and Bidder is not engaged in this transaction directly or indirectly on behalf of, or facilitating this transaction directly or indirectly on behalf of, any such person, group, entity or nation.

E. **Qualified.** Bidder has the requisite experience **minimum of 10 years**, ability, capital, facilities, plant, organization, and staff to enable Bidder to perform the Work successfully and promptly and to commence and complete the Work within the Contract Price and Contract Time set forth above. Bidder warrants and represents that it has met and will meet all required standards set forth in **Owner's Responsible Bidder Ordinance M-7-20, including, without limitation, The bidder actively participates, and has actively participated for at least 12 months before the date of the bid opening, in apprenticeship and training programs approved and**

registered with the United States department of labor bureau of apprenticeship and training for each of the trades of work contemplated under the awarded contract for all bidders and subcontractors. For the purposes of this subsection, a bidder or subcontractor is considered an active participant in an apprenticeship and training program if all eligible employees have either: (i) completed such a program, or (ii) were enrolled in such a program prior to the solicitation date and are currently participating in such program."

**7. Acknowledgements**

In submitting this Contract, Bidder acknowledges and agrees that:

A. Reliance. Owner is relying on all warranties, representations, and statements made by Bidder in this Contract.

B. Reservation of Rights. Owner reserves the right to reject any and all proposals, reserves the right to reject the low price proposal, and reserves such other rights as are set forth in the Instructions to Bidders.

C. Acceptance. If this Contract is accepted, Bidder shall be bound by each and every term, condition, or provision contained in this Contract and in Owner's written notification of acceptance in the form included in this bound set of documents.

D. Remedies. Each of the rights and remedies reserved to Owner in this Contract shall be cumulative and additional to any other or further remedies provided in law or equity or in this Contract.

E. Time. Time is of the essence for this Contract and, except where stated otherwise, references in this Contract to days shall be construed to refer to calendar days.

F. No Waiver. No examination, inspection, investigation, test, measurement, review, determination, decision, certificate, or approval by Owner, whether before or after Owner's acceptance of this Contract; nor any information or data supplied by Owner, whether before or after Owner's acceptance of this Contract; nor any order by Owner for the payment of

money; nor any payment for, or use, possession, or acceptance of, the whole or any part of the Work by Owner; nor any extension of time granted by Owner; nor any delay by Owner in exercising any right under this Contract; nor any other act or omission of Owner shall constitute or be deemed to be an acceptance of any defective, damaged, or nonconforming Work, nor operate to waive or otherwise diminish the effect of any representation or warranty made by Bidder; or of any requirement or provision of this Contract; or of any remedy, power, or right of Owner.

G. Severability. The provisions of this Contract/ Proposal shall be interpreted when possible to sustain their legality and enforceability as a whole. In the event any provision of this Contract shall be held invalid, illegal, or unenforceable by a court of competent jurisdiction, in whole or in part, neither the validity of the remaining part of such provision, nor the validity of any other provisions of this Contract shall be in any way affected thereby.

H. Amendments. No modification, addition, deletion, revision, alteration, or other change to this Contract shall be effective unless and until such change is reduced to writing and executed and delivered by Owner and Bidder, except that Owner has the right, by written order executed by Owner, to make changes in the Work ("Change Order"). If any Change Order causes an increase or decrease in the amount of the Work, then an equitable adjustment in the Contract Price or Contract Time may be made. No decrease in the amount of the Work caused by any Change Order shall entitle Bidder to make any claim for damages, anticipated profits, or other compensation.

I. Assignment. Neither this Contract, nor any interest herein, shall be assigned or subcontracted, in whole or in part, by Bidder except upon the prior written consent of Owner.

J. Governing Law. This Contract, and the rights of the parties under this Contract shall be interpreted according to the internal laws, but not the conflict of law rules, of the State of Illinois. Every provision of law required by law to be inserted into this Contract/Proposal shall be deemed to be inserted herein.

By submitting this Contract proposal in response to this Invitation to Bid, Bidder hereby represents, warrants, and certifies that:

- Bidder has carefully examined and read the ITB and all related documents in their entirety.
- The person signing the Contract proposal on behalf of Bidder is fully authorized to execute the Contract and bind Bidder to all of the terms and provisions of the Contract.
- Bidders has provided a list of client references with a minimum of **(5) five municipal** references.
- Bidder has fully completed the entire Contract form, including the Total Contract Price on page 2 of the contract and completed the entire bid pricing in Attachment A.
- Bidder has submitted a certified check or bid bond, in amount equal to at least 5 percent of the Total Contract Price.
- Bidder has checked the City's website for any addenda issued in connection with this ITB, hereby acknowledges receipt of Addenda Nos. \_\_\_\_\_ **[BIDDERS MUST INSERT ALL ADDENDA NUMBERS]**, has attached these addenda to Bidder's contract proposal, and acknowledges and agrees that, if Bidder's contract proposal is accepted, these addenda will be incorporated into the Contract and will be binding upon Bidder.
- Bidder meets all conditions of Ordinance M-7-20: RESPONSIBLE BIDDER FOR CERTAIN CONSTRUCTION CONTRACTS which is included in Attachment C. Include documents with bid submission.
- Bidder has submitted its Contract proposal in a sealed envelope that bears the full legal name of Bidder and the name of the Contract.

*John Lockett*  
Signer ID: EUV4BOUTO9...

Dated: April 8th, 2026

Bidder's Status:  Illinois Corporation ( ) Partnership ( ) Individual Proprietor  
(State) (State)

Bidder's Name: C.R. Schmidt, Inc.

Doing Business As (if different): \_\_\_\_\_

Signature of Bidder or Authorized Agent:  Date: 4.8.26

(corporate seal) Printed Name: Olivia Lockett  
(if corporation)

Title/Position: President

Bidder's Business Address: 3S215 Talbot Ave.  
Warrenville, IL 60555

Bidder's Business Telephone: 630-293-5885 Facsimile: 630-293-9300

If a corporation or partnership, list all officers or partners:

| NAME           | TITLE     | ADDRESS                                  |
|----------------|-----------|--|
| Olivia Lockett | President | 3S215 Talbot Ave., Warrenville, IL 60555 |
|                |           |  |
|                |           |  |

**ACCEPTANCE**

The Contract attached hereto and by this reference incorporated herein and made a part hereof is hereby accepted by the order of the City of Des Plaines ("Owner") as of \_\_\_\_\_, 20\_\_\_\_.

This Acceptance, together with the Contract attached hereto, constitutes the entire and only agreement between the parties relating to the accomplishment of the Work and the compensation therefor and supersedes and merges any other prior or contemporaneous discussions, agreements, or understandings, whether written or oral, and shall prevail over any contradictory or inconsistent terms or conditions contained in any purchase order, acceptance, acknowledgement, invoice, or other standard form used by the parties in the performance of the Contract. Any such contradictory or inconsistent terms or conditions shall be deemed objected to by Owner without further notice of objection and shall be of no effect nor in any circumstances binding upon Owner unless accepted by Owner in a written document plainly labeled "Amendment to Contract." Acceptance or rejection by Owner of any such contradictory or inconsistent terms or conditions shall not constitute acceptance of any other contradictory or inconsistent terms or conditions.

**CITY OF DES PLAINES**

Signature: \_\_\_\_\_  
Printed name: Dorothy Wisniewski  
Title: City Manager

## Attachment A

### Specifications for Brick Paver Repairs

- Contractor shall provide evidence that his firm or other entity propose for the unit paving work has specific experience meeting the following criteria:
  - Experience installing unit pavers using sand setting beds.
  - Installed (within past three years) a minimum of 100,000 square feet per year for the past three years of unit paving using sand setting beds.
  - The same experienced supervisory personnel will be made available for this project.
- Unit Pricing to include all mobilization, equipment, traffic control devices, materials, supplies, and removal of any spoils and other items necessary for the completion of brick paver repairs per estimated quantities on the schedule of prices in Attachment B.
- Contractor to provide prior notification to businesses affected by work 7 days prior to commencing work.
- The Contractor shall arrange to keep public ways open for traffic at their own expense. The Contractor must maintain convenient access to driveways, businesses and all buildings along the repairs. The Contractor shall remove all surplus materials and debris from the work area on a daily basis so that there is a minimum amount of disruption to public property as possible.
- Areas for brick paver removal and reset shall be completed as follows:
  - No work shall be performed when the underlayment has free moisture, ice, or snow, or when the underlayment is frozen.
  - Concrete underlayment shall be clean and free from debris and materials or substances that will hinder the bond of the setting bed.
  - Thickness of setting bed shall be one inch but can vary to allow the surface of the pavers to be at the required finished grade.
  - There shall be no variation in the depth of each paver and pavers shall be tightly butted.
  - After a sufficient area of pavers has been installed the pavers shall be compacted by running a mechanical vibratory compactor over the paved surface until the pavers are uniformly leveled, true to grade, and totally immobilized.
  - Joints between pavers shall be filled by sweeping sharp sand into the joints, when joints are filled paver surfaces shall be swept clean of any residual sand.
  - After completion of the unit pavers paver installation areas shall be thoroughly swept clean and surface shall be left unsoiled.
  - Where required by the City surface shall be cleaned with water or an approved cleaner.
- Areas that require brick paver replacement will be supplied by the City. New brick pavers to be set under the same guidelines above for pavers that were removed and reset.
- Where required pavers shall be accurately cut with a masonry or concrete saw and to reduce dust during paver installation, unit pavers shall only be cut using water. No dry cutting is permitted.

“L” shaped pavers shall be avoided where possible. Cut edges shall be plumb and straight. Scoring and breaking shall not be acceptable.

- Stockpiling of materials within the Right of Way is not permitted without the approval of the City. The contractor shall immediately remove all non -approved stockpiles from the work area. If this non-approved stockpile remains on the work area, following a 24-hour grace period, the contractor shall be penalized \$500 per calendar day each and every day that the unauthorized stockpiles remain on the work area. This penalty shall be deducted from the amounts due or which may become due to the Contractor.
- Basis of Payment: This work shall be measured and paid for at the contract unit price per square foot.

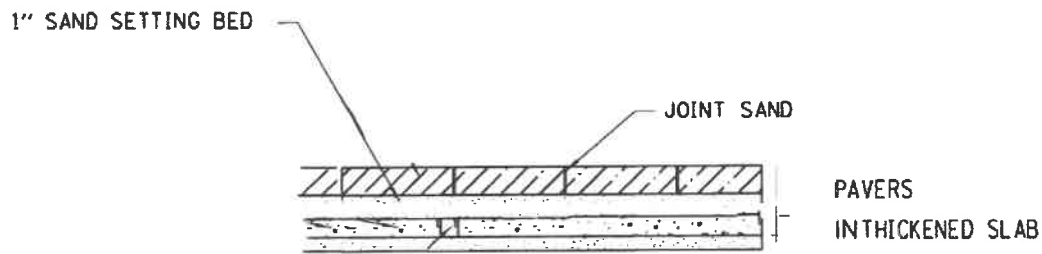

**Attachment B**

**Schedule of Prices**

| <b>Item No.</b> | <b>Item Description</b>  | <b>Unit Price<br/>per square foot</b> | <b>Total Price</b> |
|-----------------|--|---------------------------------------|--------------------|
| 1.              | All equipment, materials, and work necessary to reset 2,000 square feet of the existing unit pavers                | \$22.00                               | \$44,000.00        |
| 2.              | All equipment, materials, and work necessary to remove and install 500 square feet of new pavers supplied by City. | \$25.50                               | \$12,750.00        |

**TOTAL CONTRACT COST** \$56,750.00



**PUBLIC WORKS AND  
ENGINEERING DEPARTMENT**

1420 Miner Street  
Des Plaines, IL 60016  
P: 847.391.5390  
desplainesil.gov

**MEMORANDUM**

Date: April 23, 2026  
To: Dorothy Wisniewski, City Manager  
From: Becka Shipp, P.E., Assistant Director of Engineering *BS*  
CC: Tim Watkins, Director of Public Works & Engineering  
Subject: DCEO Grant Agreement 25-203699 – 2026 Water Main Improvements

**Issue:** The City of Des Plaines has received a \$250,000.00 grant from the Illinois Department of Commerce and Economic Opportunity (DCEO) to be used for accessibility improvements on our 2026 Water Main Improvements Project.

**Analysis:** Grant funds will be utilized for a portion of the costs associated with roadway improvements along Birch Street (Touhy to the north dead end) and Prairie Avenue (5th Street to 2nd Street). Currently, the roadways have severe drainage issues and are in poor condition. Grant funds will cover the replacement of the roadway surface and associated curbs, gutters, sidewalks, and driveways. The project will increase the health of the City's infrastructure, reduce future maintenance costs, and provide better safety and accessibility.

This work is included in the 2026 Water Main Improvement Project and will be awarded under R-123-26 to John Neri Construction, Inc at the May 4, 2026, council meeting. The source of funding for the 2026 Water Main Improvements Project is this grant (\$250,000.00) and Capital Projects Fund

**Recommendation:** We recommend approval of the intergovernmental grant agreement 25-203699 with the Illinois Department of Commerce and Economic Opportunity (DCEO).

**Attachments:**

Resolution R-122-26  
Exhibit A – Uniform Grant Budget  
Exhibit B – Intergovernmental Grant Agreement

**CITY OF DES PLAINES**

**RESOLUTION R - 122 - 26**

**A RESOLUTION AUTHORIZING THE EXECUTION OF A GRANT BUDGET AND AGREEMENT WITH THE STATE OF ILLINOIS DEPARTMENT OF COMMERCE AND ECONOMIC OPPORTUNITY.**

**WHEREAS**, Article VII, Section 10, of the 1970 Illinois Constitution authorizes the City to contract with individuals, associations and corporations, in any manner not prohibited by law or ordinance; and

**WHEREAS**, Article VII, Section 10 of the 1970 Illinois Constitution and the Illinois Intergovernmental Cooperation Act, 5 ILCS 220/1, et seq., authorize and encourage intergovernmental cooperation; and

**WHEREAS**, the City has been awarded a grant from the State of Illinois Department of Commerce and Economic Opportunity ("**DCEO**") in the amount of \$250,000.00 ("**Grant**") for improvements for accessibility in compliance with the American Disabilities Act in relation to our 2026 Water Main Improvements Project (collectively, the "**Work**"), which Work is eligible for the Grant; and

**WHEREAS**, in order to receive the Grant, the City must execute a Notice of Grant Award and Uniform Grant Budget ("**Grant Budget**") and an intergovernmental grant agreement with the DCEO ("**Agreement**"); and

**WHEREAS**, it is in the best interest of the City to approve and authorize the execution of the Grant Budget and Agreement;

**NOW, THEREFORE, BE IT RESOLVED** by the City Council of the City of Des Plaines, Cook County, Illinois, in the exercise of its home rule powers, as follows;

**SECTION 1: RECITALS.** The foregoing recitals are incorporated into, and made a part of, this Resolution as the findings of the City Council.

**SECTION 2: APPROVAL OF GRANT BUDGET.** The City Council hereby approves the Grant Budget substantially in the form attached as **Exhibit A**, and in a final form approved by the General Counsel.

**SECTION 3: AUTHORIZATION TO EXECUTE GRANT BUDGET.** The City Council hereby authorizes the Mayor and the Director of Finance, if necessary and applicable, to execute and seal, on behalf of the City, the final Grant Budget.

**SECTION 4: APPROVAL OF AGREEMENT.** The City Council hereby approves the Agreement substantially in the form attached as **Exhibit B**, and in a final form approved by the General Counsel.

**SECTION 5: AUTHORIZATION TO EXECUTE AGREEMENT.** The City Council hereby authorizes the Mayor and the Assistant Director of Public Works and Engineering, if necessary and applicable, to execute and seal, on behalf of the City, the final Agreement.

**SECTION 6: EFFECTIVE DATE.** This Resolution will be in full force and effect from and after its passage and approval according to law.

**PASSED** this \_\_\_\_ day of \_\_\_\_\_, 2026.

**APPROVED** this \_\_\_\_ day of \_\_\_\_\_, 2026.

**VOTE:** AYES \_\_\_\_ NAYS \_\_\_\_ ABSENT \_\_\_\_

\_\_\_\_\_  
**MAYOR**

Approved as to form:

ATTEST:

\_\_\_\_\_  
**CITY CLERK**

\_\_\_\_\_  
**Peter M. Friedman, General Counsel**

**EXHIBIT A**  
**GRANT BUDGET**

**EXHIBIT B**  
**AGREEMENT**

State of Illinois

UNIFORM GRANT BUDGET TEMPLATE

Agency: Illinois Department of Commerce and Economic Opportunity State FY: 2026

Grantee: City of Des Plaines UEI #: DAS9KV9SMXV3

NOFO Number: CSFA Number: Grant Number: 25-203699

CSFA Description:

**Section A: State of Illinois Funds**

**Revenues**

State of Illinois Grant Amount Requested \$250,000.00

**Budget Expenditure Categories**

- 1. Personnel (200.430)
- 2. Fringe Benefits (200.431)
- 3. Travel (200.474)
- 4. Equipment (200.439)
- 5. Supplies (200.94)
- 6. Contractual/Subawards (200.318 and .92)
- 7. Consultant (200.459)
- 8. Construction
  - 1219 PAVING/CONCRETE/MASONRY \$250,000.00
- 9. Occupancy (200.465)
- 10. Research and Development (200.87)
- 11. Telecommunications
- 12. Training and Education (200.472)
- 13. Direct Administrative Costs (200.413)
- 14. Miscellaneous Costs
- 15. Grant Exclusive Line Item(s)
- 16. Total Direct Costs (add lines 1-15) \$250,000.00
- 17. Total Indirect Costs (200.414)
  - Rate: %
  - Base: \$250,000.00
- 18. Total Costs State Grant Funds (Lines 16 and 17) \$250,000.00

Grantee:

NOFO Number:

Grant Number:

**SECTION A - Continued - Indirect Cost Rate Information**

If your organization is requesting reimbursement for indirect costs on line 17 of the Budget Summary, please select one of the following options. If not reimbursement is being requested please consult your program office regarding possible match requirements.

Your organization may not have a Federally Negotiated Cost Rate Agreement. Therefore, in order for your organization to be reimbursed for the Indirect Costs from the State of Illinois your organization must either:

- a. Negotiate an Indirect Cost Rate with the State of Illinois' Indirect Cost Unit with guidance from you State Cognizant Agency on an annual basis;
- b. Elect to use the de minimis rate of 15% modified total direct costs (MTDC) which may be used indefinitely on State of Illinois awards; or
- c. Use a Restricted Rate designated by programmatic or statutory policy (see Notice of Funding Opportunity or Restricted Rate Programs).

**Select ONLY One:**

- 1)  Our Organization receives direct Federal funding and currently has a Negotiated Indirect Cost Rate Agreement (NICRA) with our federal Cognizant Agency. A copy of this agreement will be provided to the State of Illinois' Indirect Cost Unit for review and documentation before reimbursement is allowed. This NICRA will be accepted by all State of Illinois agencies up to any statutory, rule-based or programmatic restrictions or limitations.
- 2a)  Our Organizations currently has a Negotiated Indirect Cost Rate Agreement (NICRA) with the State of Illinois that will be accepted by all State of Illinois agencies up to any statutory, rule-based or programmatic restrictions or limitations. Our Organization is required to submit a new Indirect Cost Rate Proposal to the Indirect Cost Unit within 6 months after the close of each fiscal year pursuant to 2 CFR 200, Appendix IV(c)(2)(c).
- 2b)  Our Organization currently does not have a Negotiated Indirect Cost Rate Agreement (NICRA) with the State of Illinois. Our organization will submit our initial Indirect Cost Rate Proposal (ICRP) immediately after our Organization is advised that the State award will be made no later than 3 months after the effective date of the State award pursuant to 2 CFR 200 Appendix (C)(2)(b). The initial ICRP will be sent to the State of Illinois Indirect Cost unit.
- 3)  Our Organization has never received a Negotiated Indirect Cost Rate Agreement from either the federal government or the State of Illinois and elects to charge the de minimis rate of 15% modified total direct cost (MTDC) which may be used indefinitely on State of Illinois awards pursuant to 2 CFR 200.414 (C)(4)(f) and 200.68.
- 4)  For Restricted Rate Programs, our Organization is using a restricted indirect cost rate that:
  - is included as a "Special Indirect Cost Rate" in the NICRA, pursuant to 2 CFR 200 Appendix IV(5); or
  - complies with other statutory policies.
- 5)  No reimbursement of Indirect Cost is being requested. Rate:  %

**Basic Negotiated Indirect Cost Rate Information (Use only if option 1 or 2(a), above is selected.)**

Period Covered By NICRA:  From:  To:  Approving Federal or State Agency:

Indirect Cost Rate:

% The Distribution Base Is:

Grantee: City of Des Plaines

NOFO Number: 0

Grant Number: 25-203699

**By signing this report, I certify to the best of my knowledge and belief that the report is true, complete and accurate and that any false, fictitious or fraudulent information or the omission of any material fact could result in the immediate termination of my grant award(s).**

|                           |                            |                           |                            |
|---------------------------|----------------------------|---------------------------|----------------------------|
| Institution/Organization: | <u>City of Des Plaines</u> | Institution/Organization: | <u>City of Des Plaines</u> |
| Signature:                | <u></u>                    | Signature:                | <u></u>                    |
| Printed Name:             | <u>Andrew Goczowski</u>    | Printed Name:             | <u>Agnes Podbial</u>       |
| Title:                    | <u>Mayor</u>               | Title:                    | <u>Finance Director</u>    |
| Phone:                    | <u>847-391-5301</u>        | Phone:                    | <u>847-391-5328</u>        |
| Date:                     | <u></u>                    | Date:                     | <u></u>                    |

Note: The State Awarding Agency may change required signers based on the grantee's organizational structure. The required signers must have the authority to enter into contractual agreements on the behalf of the organization.



**GRANT AGREEMENT  
BETWEEN  
THE STATE OF ILLINOIS, DEPARTMENT OF COMMERCE AND ECONOMIC OPPORTUNITY  
AND  
City of Des Plaines**

The parties to this Grant Agreement (Agreement) are the State of Illinois (State), acting through the undersigned agency (Grantor) and City of Des Plaines (Grantee) (collectively, the "Parties" and individually, a "Party"). The Agreement, consisting of the signature page, the parts listed below, and any additional exhibits or attachments referenced in this Agreement, constitute the entire agreement between the Parties. No promises, terms, or conditions not recited, incorporated or referenced herein, including prior agreements or oral discussions, are binding upon either Grantee or Grantor.

**PART ONE – The Uniform Terms**

|               |  |
|---------------|--|
| Article I     | Definitions  |
| Article II    | Award Information  |
| Article III   | Grantee Certifications and Representations                       |
| Article IV    | Payment Requirements   |
| Article V     | Scope of Award Activities/Purpose of Award                       |
| Article VI    | Budget   |
| Article VII   | Allowable Costs  |
| Article VIII  | Lobbying   |
| Article IX    | Maintenance and Accessibility of Records; Monitoring             |
| Article X     | Financial Reporting Requirements                                 |
| Article XI    | Performance Reporting Requirements                               |
| Article XII   | Audit Requirements   |
| Article XIII  | Termination; Suspension; Non-compliance                          |
| Article XIV   | Subcontracts/Subawards   |
| Article XV    | Notice of Change   |
| Article XVI   | Structural Reorganization and Reconstitution of Board Membership |
| Article XVII  | Conflict of Interest   |
| Article XVIII | Equipment or Property  |
| Article XIX   | Promotional Materials; Prior Notification                        |
| Article XX    | Insurance  |
| Article XXI   | Lawsuits and Indemnification                                     |
| Article XXII  | Miscellaneous  |
| Exhibit A     | Project Description  |
| Exhibit B     | Deliverables or Milestones                                       |
| Exhibit C     | Contact Information  |
| Exhibit D     | Performance Measures and Standards                               |
| Exhibit E     | Specific Conditions  |

**PART TWO – Grantor-Specific Terms**

**PART THREE – Project-Specific Terms**

The Parties or their duly authorized representatives hereby execute this Agreement.

ILLINOIS DEPARTMENT OF COMMERCE AND  
ECONOMIC OPPORTUNITY

CITY OF DES PLAINES

By: \_\_\_\_\_  
Signature of Kristin A. Richards, Director

By: \_\_\_\_\_  
Signature of Authorized Representative

Date: \_\_\_\_\_

Date: \_\_\_\_\_

By: \_\_\_\_\_  
Signature of Designee

Printed Name: Andrew Goczkowski

Printed Title: Mayor

Date: \_\_\_\_\_

Email: agoczkowski@desplainesil.gov

Printed Name: \_\_\_\_\_

Printed Title: \_\_\_\_\_  
Designee

By: \_\_\_\_\_  
Signature of Second Grantor Approver, if applicable

By: \_\_\_\_\_  
Signature of Second Grantee Approver, if applicable

Date: \_\_\_\_\_

Date: \_\_\_\_\_

Printed Name: \_\_\_\_\_

Printed Name: \_\_\_\_\_

Printed Title: \_\_\_\_\_  
Second Grantor Approver

Printed Title: \_\_\_\_\_  
Second Grantee Approver  
(optional at Grantee's discretion)

By: \_\_\_\_\_  
Signature of Third Grantor Approver, if applicable

Date: \_\_\_\_\_

Printed Name: \_\_\_\_\_

Printed Title: \_\_\_\_\_  
Third Grantor Approver

**PART ONE – THE UNIFORM TERMS**

**ARTICLE I  
DEFINITIONS**

1.1. Definitions. Capitalized words and phrases used in this Agreement have the meanings stated in 2 CFR 200.1 unless otherwise stated below.

“Allowable Costs” has the same meaning as in 44 Ill. Admin. Code 7000.30.

“Award” has the same meaning as in 44 Ill. Admin. Code 7000.30.

“Budget” has the same meaning as in 44 Ill. Admin. Code 7000.30.

“Catalog of State Financial Assistance” or “CSFA” has the same meaning as in 44 Ill. Admin. Code 7000.30.

“Close-out Report” means a report from the Grantee allowing Grantor to determine whether all applicable administrative actions and required work have been completed, and therefore closeout actions can commence.

“Conflict of Interest” has the same meaning as in 44 Ill. Admin. Code 7000.30.

“Cooperative Research and Development Agreement” has the same meaning as in 15 USC 3710a.

“Direct Costs” has the same meaning as in 44 Ill. Admin. Code 7000.30.

“Financial Assistance” has the same meaning as in 44 Ill. Admin. Code 7000.30.

“GATU” has the same meaning as in 44 Ill. Admin. Code 7000.30.

“Grant Agreement” has the same meaning as in 44 Ill. Admin. Code 7000.30.

“Grantee Compliance Enforcement System” has the same meaning as in 44 Ill. Admin. Code 7000.30.

“Grant Funds” means the Financial Assistance made available to Grantee through this Agreement.

“Grantee Portal” has the same meaning as in 44 Ill. Admin. Code 7000.30.

“Indirect Costs” has the same meaning as in 44 Ill. Admin. Code 7000.30.

“Indirect Cost Rate” means a device for determining in a reasonable manner the proportion of Indirect Costs each Program should bear. It is a ratio (expressed as a percentage) of the Indirect Costs to a Direct Cost base. If reimbursement of Indirect Costs is allowable under an Award, Grantor will not reimburse those Indirect Costs unless Grantee has established an Indirect Cost Rate covering the applicable activities and period of time, unless Indirect Costs are reimbursed at a fixed rate.

“Indirect Cost Rate Proposal” has the same meaning as in 44 Ill. Admin. Code 7000.30.

“Obligations” has the same meaning as in 44 Ill. Admin. Code 7000.30.

“Period of Performance” has the same meaning as in 44 Ill. Admin. Code 7000.30.

“Prior Approval” has the same meaning as in 44 Ill. Admin. Code 7000.30.

“Profit” means an entity’s total revenue less its operating expenses, interest paid, depreciation, and taxes. “Profit” is synonymous with the term “net revenue.”

“Program” means the services to be provided pursuant to this Agreement. "Program" is used interchangeably with "Project."

“Program Costs” means all Allowable Costs incurred by Grantee and the value of the contributions made by third parties in accomplishing the objectives of the Award during the Term of this Agreement.

“Related Parties” has the meaning set forth in Financial Accounting Standards Board (FASB) Accounting Standards Codification (ASC) 850-10-20.

“SAM” has the same meaning as in 44 Ill. Admin. Code 7000.30.

“State-issued Award” means the assistance that a grantee receives directly from a State agency. The funding source of the State-issued Award can be federal pass-through, State or a combination thereof. "State-issued Award" does not include the following:

- contracts issued pursuant to the Illinois Procurement Code that a State agency uses to buy goods or services from a contractor or a contract to operate State government-owned, contractor-operated facilities;
- agreements that meet the definition of "contract" under 2 CFR 200.1 and 2 CFR 200.331, which a State agency uses to procure goods or services but are exempt from the Illinois Procurement Code due to an exemption listed under 30 ILCS 500/1-10, or pursuant to a disaster proclamation, executive order, or any other exemption permitted by law;
- amounts received for services rendered to an individual;
- Cooperative Research and Development Agreements;
- an agreement that provides only direct cash assistance to an individual;
- a subsidy;
- a loan;
- a loan guarantee; or
- insurance.

“Illinois Stop Payment List” has the same meaning as in 44 Ill. Admin. Code 7000.30.

“Unallowable Cost” has the same meaning as in 44 Ill. Admin. Code 7000.30.

“Unique Entity Identifier” or “UEI” has the same meaning as in 44 Ill. Admin. Code 7000.30.

## ARTICLE II AWARD INFORMATION

2.1. Term. This Agreement is effective on **04/01/2026** and expires on **03/31/2028** (the Term), unless terminated pursuant to this Agreement.

2.2. Amount of Agreement. Grant Funds must not exceed **\$250,000.00**, of which **\$0.00** are federal funds. Grantee accepts Grantor’s payment as specified in this ARTICLE.

2.3. Payment. Payment will be made as follows (see additional payment requirements in ARTICLE IV; additional payment provisions specific to this Award may be included in **PART TWO** or **PART THREE**):

The Award amount listed in Paragraph 2.2 is not a guarantee of payment, and Grantee’s receipt of Grant Funds is contingent upon all terms and conditions of this Agreement.

Reimbursement

Payments to the Grantee are subject to the Grantee’s submission and certification of eligible costs and any documentation as required by the Grantor. Payment shall be initiated upon the Grantor’s approval of eligible costs and cash amount requested for reimbursement of those costs.

2.4. Award Identification Numbers. If applicable, the Federal Award Identification Number (FAIN) is **N/A**, the federal awarding agency is **N/A**, and the Federal Award date is **N/A**. If applicable, the Assistance Listing Program Title is **N/A** and Assistance Listing Number is **N/A**. The Catalog of State Financial Assistance (CSFA) Number is 420-00-1758 and the CSFA Name is Site Improvements. If applicable, the State Award Identification Number (SAIN) is 1758-63138.

**ARTICLE III  
GRANTEE CERTIFICATIONS AND REPRESENTATIONS**

3.1. Registration Certification. Grantee certifies that: (i) it is registered with SAM and **DAS9KV9SMXV3** is Grantee’s correct UEI; (ii) it is in good standing with the Illinois Secretary of State, if applicable; and (iii) Grantee has successfully completed the annual registration and prequalification through the Grantee Portal.

Grantee must remain current with these registrations and requirements. If Grantee’s status with regard to any of these requirements changes, or the certifications made in and information provided in the uniform grant application changes, Grantee must notify Grantor in accordance with ARTICLE XV.

3.2. Tax Identification Certification. Grantee certifies that: **366005849** is Grantee’s correct federal employer identification number (FEIN) or Social Security Number. Grantee further certifies, if applicable: (a) that Grantee is not subject to backup withholding because (i) Grantee is exempt from backup withholding, or (ii) Grantee has not been notified by the Internal Revenue Service (IRS) that Grantee is subject to backup withholding as a result of a failure to report all interest or dividends, or (iii) the IRS has notified Grantee that Grantee is no longer subject to backup withholding; and (b) Grantee is a U.S. citizen or other U.S. person. Grantee is doing business as a (check one):

- |                                     |                                       |                          |  |
|-------------------------------------|---------------------------------------|--------------------------|--|
| <input type="checkbox"/>            | Individual                            | <input type="checkbox"/> | Pharmacy-Non Corporate   |
| <input type="checkbox"/>            | Sole Proprietorship                   | <input type="checkbox"/> | Pharmacy/Funeral Home/Cemetery Corp.                             |
| <input type="checkbox"/>            | Partnership                           | <input type="checkbox"/> | Tax Exempt   |
| <input type="checkbox"/>            | Corporation (includes Not For Profit) | <input type="checkbox"/> | Limited Liability Company (select applicable tax classification) |
| <input type="checkbox"/>            | Medical Corporation                   |                          |  |
| <input checked="" type="checkbox"/> | Governmental Unit                     | <input type="checkbox"/> | P = partnership  |
| <input type="checkbox"/>            | Estate or Trust                       | <input type="checkbox"/> | C = corporation  |

If Grantee has not received a payment from the State of Illinois in the last two years, Grantee must submit a W-9 tax form with this Agreement.

3.3. Compliance with Uniform Grant Rules. Grantee certifies that it must adhere to the applicable Uniform Administrative Requirements, Cost Principles, and Audit Requirements for Federal Awards, which are published in Title 2, Part 200 of the Code of Federal Regulations (2 CFR Part 200) and are incorporated herein by reference. 44 Ill. Admin. Code 7000.40(c)(1)(A). The requirements of 2 CFR Part 200 apply to the Grant Funds awarded through this Agreement, regardless of whether the original source of the funds is State or federal, unless an exception is noted in federal or State statutes or regulations. 30 ILCS 708/5(b).

3.4. **Representations and Use of Funds.** Grantee certifies under oath that (1) all representations made in this Agreement are true and correct and (2) all Grant Funds awarded pursuant to this Agreement must be used only for the purpose(s) described herein. Grantee acknowledges that the Award is made solely upon this certification and that any false statements, misrepresentations, or material omissions will be the basis for immediate termination of this Agreement and repayment of all Grant Funds.

3.5. **Specific Certifications.** Grantee is responsible for compliance with the enumerated certifications in this Paragraph to the extent that the certifications apply to Grantee.

(a) **Bribery.** Grantee certifies that it has not been convicted of bribery or attempting to bribe an officer or employee of the State of Illinois, nor made an admission of guilt of such conduct which is a matter of record.

(b) **Bid Rigging.** Grantee certifies that it has not been barred from contracting with a unit of State or local government as a result of a violation of Paragraph 33E-3 or 33E-4 of the Criminal Code of 2012 (720 ILCS 5/33E-3 or 720 ILCS 5/33E-4, respectively).

(c) **Debt to State.** Grantee certifies that neither it, nor its affiliate(s), is/are barred from receiving an Award because Grantee, or its affiliate(s), is/are delinquent in the payment of any debt to the State, unless Grantee, or its affiliate(s), has/have entered into a deferred payment plan to pay off the debt.

(d) **International Boycott.** Grantee certifies that neither it nor any substantially owned affiliated company is participating or will participate in an international boycott in violation of the provision of the Anti-Boycott Act of 2018, Part II of the Export Control Reform Act of 2018 (50 USC 4841 through 4843), and the anti-boycott provisions set forth in Part 760 of the federal Export Administration Regulations (15 CFR Parts 730 through 774).

(e) **Discriminatory Club Dues or Fees.** Grantee certifies that it is not prohibited from receiving an Award because it pays dues or fees on behalf of its employees or agents, or subsidizes or otherwise reimburses employees or agents for payment of their dues or fees to any club which unlawfully discriminates (775 ILCS 25/2).

(f) **Pro-Children Act.** Grantee certifies that it is in compliance with the Pro-Children Act of 2001 in that it prohibits smoking in any portion of its facility used for the provision of health, day care, early childhood development services, education or library services to children under the age of eighteen (18) (except such portions of the facilities which are used for inpatient substance abuse treatment) (20 USC 7181-7184).

(g) **Drug-Free Workplace.** If Grantee is not an individual, Grantee certifies it will provide a drug free workplace pursuant to the Drug Free Workplace Act. 30 ILCS 580/3. If Grantee is an individual and this Agreement is valued at more than \$5,000, Grantee certifies it will not engage in the unlawful manufacture, distribution, dispensation, possession, or use of a controlled substance during the performance of the Agreement. 30 ILCS 580/4. Grantee further certifies that if it is a recipient of federal pass-through funds, it is in compliance with the government-wide requirements for a drug-free workplace as set forth in 41 USC 8103.

(h) **Motor Voter Law.** Grantee certifies that it is in full compliance with the terms and provisions of the National Voter Registration Act of 1993 (52 USC 20501 et seq.).

(i) **Clean Air Act and Clean Water Act.** Grantee certifies that it is in compliance with all applicable standards, orders or regulations issued pursuant to the Clean Air Act (42 USC 7401 et seq.) and the Federal Water Pollution Control Act, as amended (33 USC 1251 et seq.).

(j) **Debarment.** Grantee certifies that it is not debarred, suspended, proposed for debarment or permanent inclusion on the Illinois Stop Payment List, declared ineligible, or voluntarily excluded from participation in this Agreement by any federal department or agency (2 CFR 200.205(a)), or by the State (30 ILCS 708/25(6)(G)).

(k) **Non-procurement Debarment and Suspension.** Grantee certifies that it is in compliance with Subpart C of 2 CFR Part 180 as supplemented by 2 CFR Part 376, Subpart C.

(l) **Health Insurance Portability and Accountability Act.** Grantee certifies that it is in compliance with the Health Insurance Portability and Accountability Act of 1996 (HIPAA) (Public Law No. 104-191, 45 CFR Parts 160, 162 and 164, and the Social Security Act, 42 USC 1320d-2 through 1320d-7), in that it may not use or disclose protected health information other than as permitted or required by law and agrees to use appropriate safeguards to prevent use or disclosure of the protected health information. Grantee must maintain, for a minimum of six (6) years, all protected health information.

(m) **Criminal Convictions.** Grantee certifies that:

(i) Neither it nor a managerial agent of Grantee (for non-governmental grantees only, this includes any officer, director or partner of Grantee) has been convicted of a felony under the Sarbanes-Oxley Act of 2002, nor a Class 3 or Class 2 felony under Illinois Securities Law of 1953, or that at least five (5) years have passed since the date of the conviction; and

(ii) It must disclose to Grantor all violations of criminal law involving fraud, bribery or gratuity violations potentially affecting this Award. Failure to disclose may result in remedial actions as stated in the Grant Accountability and Transparency Act. 30 ILCS 708/40. Additionally, if Grantee receives over \$10 million in total federal Financial Assistance, during the period of this Award, Grantee must maintain the currency of information reported to SAM regarding civil, criminal or administrative proceedings as required by 2 CFR 200.113 and Appendix XII of 2 CFR Part 200, and 30 ILCS 708/40.

(n) **Federal Funding Accountability and Transparency Act of 2006 (FFATA).** Grantee certifies that it is in compliance with the terms and requirements of 31 USC 6101 with respect to Federal Awards greater than or equal to \$30,000. A FFATA subaward report must be filed by the end of the month following the month in which the award was made.

(o) **Illinois Works Review Panel.** For Awards made for public works projects, as defined in the Illinois Works Jobs Program Act, Grantee certifies that it and any contractor(s) or subcontractor(s) that performs work using funds from this Award, must, upon reasonable notice, appear before and respond to requests for information from the Illinois Works Review Panel. 30 ILCS 559/20-25(d).

(p) **Anti-Discrimination.** Grantee certifies that its employees and subcontractors under subcontract made pursuant to this Agreement, must comply with all applicable provisions of State and federal laws and regulations pertaining to nondiscrimination, sexual harassment and equal employment opportunity including, but not limited to: Illinois Human Rights Act (775 ILCS 5/1-101 et seq.), including, without limitation, 44 Ill. Admin. Code 750- Appendix A, which is incorporated herein; Public Works Employment Discrimination Act (775 ILCS 10/1 et seq.); Civil Rights Act of 1964 (as amended) (42 USC 2000a - 2000h-6); Section 504 of the Rehabilitation Act of 1973 (29 USC 794); Americans with Disabilities Act of 1990 (as amended) (42 USC 12101 et seq.); and the Age Discrimination Act of 1975 (42 USC 6101 et seq.).

(q) **Internal Revenue Code and Illinois Income Tax Act.** Grantee certifies that it complies with all provisions of the federal Internal Revenue Code (26 USC 1), the Illinois Income Tax Act (35 ILCS 5),

and all regulations and rules promulgated thereunder, including withholding provisions and timely deposits of employee taxes and unemployment insurance taxes.

#### ARTICLE IV PAYMENT REQUIREMENTS

4.1. Availability of Appropriation; Sufficiency of Funds. This Agreement is contingent upon and subject to the availability of sufficient funds. Grantor may terminate or suspend this Agreement, in whole or in part, without penalty or further payment being required, if (i) sufficient funds for this Agreement have not been appropriated or otherwise made available to Grantor by the State or the federal funding source, (ii) the Governor or Grantor reserves funds, or (iii) the Governor or Grantor determines that funds will not or may not be available for payment. Grantor must provide notice, in writing, to Grantee of any such funding failure and its election to terminate or suspend this Agreement as soon as practicable. Any suspension or termination pursuant to this Paragraph will be effective upon the date of the written notice unless otherwise indicated.

4.2. Pre-Award Costs. Pre-award costs are not permitted unless specifically authorized by Grantor in **Exhibit A, PART TWO** or **PART THREE** of this Agreement. If they are authorized, pre-award costs must be charged to the initial Budget Period of the Award, unless otherwise specified by Grantor. 2 CFR 200.458.

4.3. Return of Grant Funds. Grantee must liquidate all Obligations incurred under the Award within forty-five (45) days of the end of the Period of Performance, or in the case of capital improvement Awards, within forty-five (45) days of the end of the time period the Grant Funds are available for expenditure or obligation, unless Grantor permits a longer period in **PART TWO** OR **PART THREE**. Grantee must return to Grantor within forty-five (45) days of the end of the applicable time period as set forth in this Paragraph all remaining Grant Funds that are not expended or legally obligated.

4.4. Cash Management Improvement Act of 1990. Unless notified otherwise in **PART TWO** or **PART THREE**, Grantee must manage federal funds received under this Agreement in accordance with the Cash Management Improvement Act of 1990 (31 USC 6501 et seq.) and any other applicable federal laws or regulations. 2 CFR 200.305; 44 Ill. Admin. Code 7000.120.

4.5. Payments to Third Parties. Grantor will have no liability to Grantee when Grantor acts in good faith to redirect all or a portion of any Grantee payment to a third party. Grantor will be deemed to have acted in good faith when it is in possession of information that indicates Grantee authorized Grantor to intercept or redirect payments to a third party or when so ordered by a court of competent jurisdiction.

4.6. Modifications to Estimated Amount. If the Agreement amount is established on an estimated basis, then it may be increased by mutual agreement at any time during the Term. Grantor may decrease the estimated amount of this Agreement at any time during the Term if (i) Grantor believes Grantee will not use the funds during the Term, (ii) Grantor believes Grantee has used Grant Funds in a manner that was not authorized by this Agreement, (iii) sufficient funds for this Agreement have not been appropriated or otherwise made available to Grantor by the State or the federal funding source, (iv) the Governor or Grantor reserves funds, or (v) the Governor or Grantor determines that funds will or may not be available for payment. Grantee will be notified, in writing, of any adjustment of the estimated amount of this Agreement. In the event of such reduction, services provided by Grantee under **Exhibit A** may be reduced accordingly. Grantor must pay Grantee for work satisfactorily performed prior to the date of the notice regarding adjustment. 2 CFR 200.308.

4.7. Interest.

(a) All interest earned on Grant Funds held by a Grantee or a subrecipient will be treated in accordance with 2 CFR 200.305(b)(12), unless otherwise provided in **PART TWO** or **PART THREE**. Grantee

and its subrecipients must remit annually any amount due in accordance with 2 CFR 200.305(b)(12) or to Grantor, as applicable.

(b) Grant Funds must be placed in an insured account, whenever possible, that bears interest, unless exempted under 2 CFR 200.305(b)(10), (b)(11).

4.8. Timely Billing Required. Grantee must submit any payment request to Grantor within fifteen (15) days of the end of the quarter, unless another billing schedule is specified in ARTICLE II, **PART TWO**, or **PART THREE**. Failure to submit such payment request timely will render the amounts billed Unallowable Costs which Grantor cannot reimburse. In the event that Grantee is unable, for good cause, to submit its payment request timely, Grantee shall timely notify Grantor and may request an extension of time to submit the payment request. Grantor's approval of Grantee's request for an extension shall not be unreasonably withheld.

4.9. Certification. Pursuant to 2 CFR 200.415, each invoice and report submitted by Grantee (or subrecipient) must contain the following certification by an official authorized to legally bind Grantee (or subrecipient):

By signing this report [or payment request or both], I certify to the best of my knowledge and belief that the report [or payment request] is true, complete, and accurate; that the expenditures, disbursements and cash receipts are for the purposes and objectives set forth in the terms and conditions of the State or federal pass-through award; and that supporting documentation has been submitted as required by the grant agreement. I acknowledge that approval for any other expenditure described herein is considered conditional subject to further review and verification in accordance with the monitoring and records retention provisions of the grant agreement. I am aware that any false, fictitious, or fraudulent information, or the omission of any material fact, may subject me to criminal, civil or administrative penalties for fraud, false statements, false claims or otherwise (U.S. Code Title 18, Sections 2, 1001, 1343 and Title 31, Sections 3729-3730 and 3801-3812; 30 ILCS 708/120).

## ARTICLE V

### SCOPE OF AWARD ACTIVITIES/PURPOSE OF AWARD

5.1. Scope of Award Activities/Purpose of Award. Grantee must perform as described in this Agreement, including as described in **Exhibit A** (Project Description), **Exhibit B** (Deliverables or Milestones), and **Exhibit D** (Performance Measures and Standards), as applicable. Grantee must further comply with all terms and conditions set forth in the Notice of State Award (44 Ill. Admin. Code 7000.360) which is incorporated herein by reference. All Grantor-specific provisions and programmatic reporting required under this Agreement are described in **PART TWO** (Grantor-Specific Terms). All Project-specific provisions and reporting required under this Agreement are described in **PART THREE** (Project-Specific Terms).

5.2. Scope Revisions. Grantee must obtain Prior Approval from Grantor whenever a scope revision is necessary for one or more of the reasons enumerated in 44 Ill. Admin. Code 7000.370(b)(2). All requests for scope revisions that require Grantor approval must be signed by Grantee's authorized representative and submitted to Grantor for approval. Expenditure of funds under a requested revision is prohibited and will not be reimbursed if expended before Grantor gives written approval. 2 CFR 200.308.

5.3. Specific Conditions. If applicable, specific conditions required after a risk assessment are included in **Exhibit E**. Grantee must adhere to the specific conditions listed therein. 44 Ill. Admin. Code 7000.340(e).

## ARTICLE VI

## BUDGET

6.1. Budget. The Budget submitted by Grantee at application, or a revised Budget subsequently submitted and approved by Grantor, is considered final and is incorporated herein by reference.

6.2. Budget Revisions. Grantee must obtain Prior Approval, whether mandated or discretionary, from Grantor whenever a Budget revision is necessary for one or more of the reasons enumerated in 44 Ill. Admin. Code 7000.370(b). All requests for Budget revisions that require Grantor approval must be signed by Grantee's authorized representative and submitted to Grantor for approval. Expenditure of funds under a requested revision is prohibited and will not be reimbursed if expended before Grantor gives written approval.

6.3. Notification. Within thirty (30) calendar days from the date of receipt of the request for Budget revisions, Grantor will review the request and notify Grantee whether the Budget revision has been approved, denied, or the date upon which a decision will be reached. 44 Ill. Admin. Code 7000.370(b)(7).

## ARTICLE VII ALLOWABLE COSTS

7.1. Allowability of Costs; Cost Allocation Methods. The allowability of costs and cost allocation methods for work performed under this Agreement will be determined in accordance with 2 CFR Part 200 Subpart E and Appendices III, IV, V, and VII.

7.2. Indirect Cost Rate Submission.

(a) All grantees, except for Local Education Agencies (as defined in 34 CFR 77.1), must make an Indirect Cost Rate election in the Grantee Portal, even grantees that do not charge or expect to charge Indirect Costs. 44 Ill. Admin. Code 7000.420(e).

(i) Waived and de minimis Indirect Cost Rate elections will remain in effect until Grantee elects a different option.

(b) Grantee must submit an Indirect Cost Rate Proposal in accordance with federal and State regulations, in a format prescribed by Grantor. For grantees who have never negotiated an Indirect Cost Rate before, the Indirect Cost Rate Proposal must be submitted for approval no later than three months after the effective date of the Award. For grantees who have previously negotiated an Indirect Cost Rate, the Indirect Cost Rate Proposal must be submitted for approval within 180 days of Grantee's fiscal year end, as dictated in the applicable appendices, such as:

(i) Appendix VII to 2 CFR Part 200 governs Indirect Cost Rate Proposals for state and Local Governments and Indian Tribes,

(ii) Appendix III to 2 CFR Part 200 governs Indirect Cost Rate Proposals for public and private institutions of higher education,

(iii) Appendix IV to 2 CFR Part 200 governs Indirect (F&A) Costs Identification and Assignment, and Rate Determination for Nonprofit Organizations, and

(iv) Appendix V to 2 CFR Part 200 governs state/Local Government-wide Central Service Cost Allocation Plans.

(c) A grantee who has a current, applicable rate negotiated by a cognizant federal agency must provide to Grantor a copy of its Indirect Cost Rate acceptance letter from the federal government and a copy of all documentation regarding the allocation methodology for costs used to negotiate that rate, e.g., without limitation, the cost policy statement or disclosure narrative statement. Grantor will accept that Indirect Cost Rate, up to any statutory, rule-based or programmatic limit.

(d) A grantee who does not have a current negotiated rate, may elect to charge a *de minimis* rate up to 15 percent of modified total direct costs, which may be used indefinitely. No documentation is required to justify the *de minimis* Indirect Cost Rate. 2 CFR 200.414(f).

7.3. Transfer of Costs. Cost transfers between Grants, whether as a means to compensate for cost overruns or for other reasons, are unallowable. 2 CFR 200.451.

7.4. Commercial Organization Cost Principles. The federal cost principles and procedures for cost analysis and the determination, negotiation and allowance of costs that apply to commercial organizations are set forth in 48 CFR Part 31.

7.5. Financial Management Standards. The financial management systems of Grantee must meet the following standards:

(a) **Accounting System.** Grantee organizations must have an accounting system that provides accurate, current, and complete disclosure of all financial transactions related to each state- and federally-funded Program. Accounting records must contain information pertaining to State and federal pass-through awards, authorizations, Obligations, unobligated balances, assets, outlays, and income. These records must be maintained on a current basis and balanced at least quarterly. Cash contributions to the Program from third parties must be accounted for in the general ledger with other Grant Funds. Third party in-kind (non-cash) contributions are not required to be recorded in the general ledger, but must be under accounting control, possibly through the use of a memorandum ledger. To comply with 2 CFR 200.305(b)(9) and 30 ILCS 708/97, Grantee must use reasonable efforts to ensure that funding streams are delineated within Grantee's accounting system. 2 CFR 200.302.

(b) **Source Documentation.** Accounting records must be supported by such source documentation as canceled checks, bank statements, invoices, paid bills, donor letters, time and attendance records, activity reports, travel reports, contractual and consultant agreements, and subaward documentation. All supporting documentation must be clearly identified with the Award and general ledger accounts which are to be charged or credited.

(i) The documentation standards for salary charges to Grants are prescribed by 2 CFR 200.430, and in the cost principles applicable to the Grantee's organization.

(ii) If records do not meet the standards in 2 CFR 200.430, then Grantor may notify Grantee in **PART TWO, PART THREE** or **Exhibit E** of the requirement to submit personnel activity reports. 2 CFR 200.430(g)(8). Personnel activity reports must account on an after-the-fact basis for one hundred percent (100%) of the employee's actual time, separately indicating the time spent on the Award, other grants or projects, vacation or sick leave, and administrative time, if applicable. The reports must be signed by the employee, approved by the appropriate official, and coincide with a pay period. These time records must be used to record the distribution of salary costs to the appropriate accounts no less frequently than quarterly.

(iii) Formal agreements with independent contractors, such as consultants, must include a description of the services to be performed, the period of performance, the fee and method of payment, an itemization of travel and other costs which are chargeable to the agreement, and the signatures of both the contractor and an appropriate official of Grantee.

(iv) If third party in-kind (non-cash) contributions are used for Award purposes, the valuation of these contributions must be supported with adequate documentation.

(c) **Internal Control.** Grantee must maintain effective control and accountability for all cash, real and personal property, and other assets. Grantee must adequately safeguard all such property and must provide assurance that it is used solely for authorized purposes. Grantee must also have systems in place that provide reasonable assurance that the information is accurate, allowable, and compliant with the terms and conditions of this Agreement. 2 CFR 200.303.

(d) **Budget Control.** Grantee must maintain records of expenditures for each Award by the cost categories of the approved Budget (including Indirect Costs that are charged to the Award), and actual expenditures are to be compared with budgeted amounts at least quarterly.

(e) **Cash Management.** Requests for advance payment must be limited to Grantee's immediate cash needs. Grantee must have written procedures to minimize the time elapsing between the receipt and the disbursement of Grant Funds to avoid having excess funds on hand. 2 CFR 200.305.

7.6. **Profits.** It is not permitted for any person or entity to earn a Profit from an Award. See, e.g., 2 CFR 200.400(g); see also 30 ILCS 708/60(a)(7).

7.7. **Management of Program Income.** Grantee is encouraged to earn income to defray Program Costs where appropriate, subject to 2 CFR 200.307.

## ARTICLE VIII LOBBYING

8.1. **Improper Influence.** Grantee certifies that it will not use and has not used Grant Funds to influence or attempt to influence an officer or employee of any government agency or a member or employee of the State or federal legislature in connection with the awarding of any agreement, the making of any grant, the making of any loan, the entering into of any cooperative agreement, or the extension, continuation, renewal, amendment or modification of any agreement, grant, loan or cooperative agreement. Additionally, Grantee certifies that it has filed the required certification under the Byrd Anti-Lobbying Amendment (31 USC 1352), if applicable.

8.2. **Federal Form LLL.** If any federal funds, other than federally-appropriated funds, were paid or will be paid to any person for influencing or attempting to influence any of the above persons in connection with this Agreement, the undersigned must also complete and submit Federal Form LLL, Disclosure of Lobbying Activities Form, in accordance with its instructions.

8.3. **Lobbying Costs.** Grantee certifies that it is in compliance with the restrictions on lobbying set forth in 2 CFR 200.450. For any Indirect Costs associated with this Agreement, total lobbying costs must be separately identified in the Program Budget, and thereafter treated as other Unallowable Costs.

8.4. **Procurement Lobbying.** Grantee warrants and certifies that it and, to the best of its knowledge, its subrecipients have complied and will comply with Illinois Executive Order No. 1 (2007) (EO 1-2007). EO 1-2007 generally prohibits grantees and subcontractors from hiring the then-serving Governor's family members to lobby procurement activities of the State, or any other unit of government in Illinois including local governments, if that procurement may result in a contract valued at over \$25,000. This prohibition also applies to hiring for that same purpose any former State employee who had procurement authority at any time during the one-year period preceding the procurement lobbying activity.

8.5. **Subawards.** Grantee must include the language of this ARTICLE in the award documents for any subawards made pursuant to this Award at all tiers. All subrecipients are also subject to certification and disclosure. Pursuant to Appendix II(I) to 2 CFR Part 200, Grantee must forward all disclosures by contractors regarding this certification to Grantor.

8.6. **Certification.** This certification is a material representation of fact upon which reliance was placed to enter into this transaction and is a prerequisite for this transaction, pursuant to 31 USC 1352. Any person who fails to file the required certifications will be subject to a civil penalty of not less than \$10,000, and not more than \$100,000, for each such failure.

**ARTICLE IX  
MAINTENANCE AND ACCESSIBILITY OF RECORDS; MONITORING**

9.1. Records Retention. Grantee must maintain for three (3) years from the date of submission of the final expenditure report, adequate books, all financial records and, supporting documents, statistical records, and all other records pertinent to this Award, adequate to comply with 2 CFR 200.334, unless a different retention period is specified in 2 CFR 200.334, 44 Ill. Admin. Code 7000.430(a) and (b) or **PART TWO** or **PART THREE**. If any litigation, claim or audit is started before the expiration of the retention period, the records must be retained until all litigation, claims or audit exceptions involving the records have been resolved and final action taken.

9.2. Accessibility of Records. Grantee, in compliance with 2 CFR 200.337 and 44 Ill. Admin. Code 7000.430(f), must make books, records, related papers, supporting documentation and personnel relevant to this Agreement available to authorized Grantor representatives, the Illinois Auditor General, Illinois Attorney General, any Executive Inspector General, Grantor's Inspector General, federal authorities, any person identified in 2 CFR 200.337, and any other person as may be authorized by Grantor (including auditors), by the State of Illinois or by federal statute. Grantee must cooperate fully in any such audit or inquiry.

9.3. Failure to Maintain Books and Records. Failure to maintain adequate books, records and supporting documentation, as described in this ARTICLE, will result in the disallowance of costs for which there is insufficient supporting documentation and also establishes a presumption in favor of the State for the recovery of any Grant Funds paid by the State under this Agreement for which adequate books, records and supporting documentation are not available to support disbursement.

9.4. Monitoring and Access to Information. Grantee must monitor its activities to assure compliance with applicable state and federal requirements and to assure its performance expectations are being achieved. Grantor will monitor the activities of Grantee to assure compliance with all requirements, including applicable programmatic rules, regulations, and guidelines that the Grantor promulgates or implements, and performance expectations of the Award. Grantee must timely submit all financial and performance reports, and must supply, upon Grantor's request, documents and information relevant to the Award. Grantor may make site visits as warranted by Program needs. 2 CFR 200.329; 200.332. Additional monitoring requirements may be in **PART TWO** or **PART THREE**.

**ARTICLE X  
FINANCIAL REPORTING REQUIREMENTS**

10.1. Required Periodic Financial Reports. Grantee must submit financial reports as requested and in the format required by Grantor no later than the dues date(s) specified in **PART TWO** or **PART THREE**. Grantee must submit reports to Grantor describing the expenditure(s) of the funds related thereto at the intervals specified by Grantor, which must be no less frequent than annually and no more frequent than quarterly, unless otherwise specified in either PART TWO or PART THREE (approved as an exception by GATU) or on Exhibit E pursuant to specific conditions. 2 CFR 200.328(b). Any report required by 30 ILCS 708/125 may be detailed in **PART TWO** or **PART THREE**.

10.2. Financial Close-out Report.

(a) Grantee must submit a financial Close-out Report, in the format required by Grantor, by the due date specified in **PART TWO** or **PART THREE**, which must be no later than sixty (60) calendar days following the end of the Period of Performance for this Agreement or Agreement termination. The format of this financial Close-out Report must follow a format prescribed by Grantor. 2 CFR 200.344; 44 Ill. Admin. Code 7000.440(b).

(b) If an audit or review of Grantee occurs and results in adjustments after Grantee submits a Close-out Report, Grantee must submit a new financial Close-out Report based on audit adjustments, and immediately submit a refund to Grantor, if applicable. 2 CFR 200.345; 44 Ill. Admin. Code 7000.450.

10.3. Effect of Failure to Comply. Failure to comply with the reporting requirements in this Agreement may cause a delay or suspension of funding or require the return of improper payments or Unallowable Costs, and will be considered a material breach of this Agreement. Grantee's failure to comply with ARTICLE X, ARTICLE XI, or ARTICLE XVII will be considered prima facie evidence of a breach and may be admitted as such, without further proof, into evidence in an administrative proceeding before Grantor, or in any other legal proceeding. Grantee should refer to the State Grantee Compliance Enforcement System for policy and consequences for failure to comply. 44 Ill. Admin. Code 7000.80.

## ARTICLE XI PERFORMANCE REPORTING REQUIREMENTS

11.1. Required Periodic Performance Reports. Grantee must submit performance reports as requested and in the format required by Grantor no later than the due date(s) specified in PART TWO or PART THREE. 44 Ill. Admin. Code 7000.410. Grantee must report to Grantor on the performance measures listed in Exhibit D, PART TWO or PART THREE at the intervals specified by Grantor, which must be no less frequent than annually and no more frequent than quarterly, unless otherwise specified in either PART TWO or PART THREE (approved as an exception by GATU), or on Exhibit E pursuant to specific conditions. For certain construction-related Awards, such reports may be exempted as identified in PART TWO or PART THREE. 2 CFR 200.329.

11.2. Performance Close-out Report. Grantee must submit a performance Close-out Report, in the format required by Grantor by the due date specified in PART TWO or PART THREE, which must be no later than 60 calendar days following the end of the Period of Performance or Agreement termination. 2 CFR 200.344; 44 Ill. Admin. Code 7000.440(b).

11.3. Content of Performance Reports. Pursuant to 2 CFR 200.329(b) and (c), all performance reports must relate the financial data and project or program accomplishments to the performance goals and objectives of this Award and also include the following: a comparison of actual accomplishments to the objectives of the Award established for the reporting period (for example, comparing costs to units of accomplishment); computation of the cost and demonstration of cost effective practices (e.g., through unit cost data); performance trend data and analysis if required; the reasons why established goals were not met, if appropriate; and additional information, analysis, and explanation of any cost overruns or higher-than-expected unit costs. Additional content and format guidelines for the performance reports will be determined by Grantor contingent on the Award's statutory, regulatory and administrative requirements, and are included in PART TWO or PART THREE of this Agreement.

## ARTICLE XII AUDIT REQUIREMENTS

12.1. Audits. Grantee is subject to the audit requirements contained in the Single Audit Act Amendments of 1996 (31 USC 7501-7507), Subpart F of 2 CFR Part 200, and the audit rules and policies set forth by the Governor's Office of Management and Budget. 30 ILCS 708/65(c); 44 Ill. Admin. Code 7000.90.

12.2. Consolidated Year-End Financial Reports (CYEFR). All grantees must complete and submit a CYEFR through the Grantee Portal, except those exempted by federal or State statute or regulation, as set forth in PART TWO or PART THREE. The CYEFR is a required schedule in Grantee's audit report if Grantee is required to complete and submit an audit report as set forth herein.

(a) Grantee's CYEFR must cover the same period as the audited financial statements, if required, and must be submitted in accordance with the audit schedule at 44 Ill. Admin. Code 7000.90. If Grantee is not required to complete audited financial statements, the CYEFR must cover Grantee's fiscal year and must be submitted within 6 months of the Grantee's fiscal year-end.

(b) The CYEFR must include an in relation to opinion from the auditor of the financial statements included in the audit.

(c) The CYEFR must follow a format prescribed by Grantor.

12.3. Entities That Are Not "For-Profit".

(a) This Paragraph applies to Grantees that are not "for-profit" entities.

(b) Single and Program-Specific Audits. If, during its fiscal year, Grantee expends at least \$1,000,000 in federal Awards (direct federal and federal pass-through awards combined), Grantee must have a single audit or program-specific audit conducted for that year as required by 2 CFR 200.501 and other applicable sections of Subpart F of 2 CFR Part 200. The audit report packet must be completed as described in 2 CFR 200.512 (single audit) or 2 CFR 200.507 (program-specific audit), 44 Ill. Admin. Code 7000.90(h)(1) and the current GATA audit manual and submitted to the Federal Audit Clearinghouse, as required by 2 CFR 200.512. The results of peer and external quality control reviews, management letters issued by the auditors and their respective corrective action plans if significant deficiencies or material weaknesses are identified, and the CYEFR(s) must be submitted to the Grantee Portal at the same time the audit report packet is submitted to the Federal Audit Clearinghouse. The due date of all required submissions set forth in this Paragraph is the earlier of (i) thirty (30) calendar days after receipt of the auditor's report(s) or (ii) nine (9) months after the end of Grantee's audit period.

(c) Financial Statement Audit. If, during its fiscal year, Grantee expends less than \$1,000,000 in federal Awards, Grantee is subject to the following audit requirements:

(i) If, during its fiscal year, Grantee expends at least \$750,000 in State-issued Awards, Grantee must have a financial statement audit conducted in accordance with the Generally Accepted Government Auditing Standards (GAGAS). Grantee may be subject to additional requirements in **PART TWO**, **PART THREE** or **Exhibit E** based on Grantee's risk profile.

(ii) If, during its fiscal year, Grantee expends less than \$750,000 in State-issued Awards, but expends at least \$500,000 in State-issued Awards, Grantee must have a financial statement audit conducted in accordance with the Generally Accepted Auditing Standards (GAAS).

(iii) If Grantee is a Local Education Agency (as defined in 34 CFR 77.1), Grantee must have a financial statement audit conducted in accordance with GAGAS, as required by 23 Ill. Admin. Code 100.110, regardless of the dollar amount of expenditures of State-issued Awards.

(iv) If Grantee does not meet the requirements in subsections 12.3(b) and 12.3(c)-(iii) but is required to have a financial statement audit conducted based on other regulatory requirements, Grantee must submit those audits for review.

(v) Grantee must submit its financial statement audit report packet, as set forth in 44 Ill. Admin. Code 7000.90(h)(2) and the current GATA audit manual, to the Grantee Portal within the earlier of (i) thirty (30) calendar days after receipt of the auditor's report(s) or (ii) six (6) months after the end of Grantee's audit period.

12.4. "For-Profit" Entities.

(a) This Paragraph applies to Grantees that are "for-profit" entities.

(b) **Program-Specific Audit.** If, during its fiscal year, Grantee expends at least \$1,000,000 in federal pass-through funds from State-issued Awards, Grantee must have a program-specific audit conducted in accordance with 2 CFR 200.507. The auditor must audit federal pass-through programs with federal pass-through Awards expended that, in the aggregate, cover at least 50 percent (0.50) of total federal pass-through Awards expended. The audit report packet must be completed as described in 2 CFR 200.507 (program-specific audit), 44 Ill. Admin. Code 7000.90 and the current GATA audit manual, and must be submitted to the Grantee Portal. The due date of all required submissions set forth in this Paragraph is the earlier of (i) thirty (30) calendar days after receipt of the auditor's report(s) or (ii) nine (9) months after the end of Grantee's audit period.

(c) **Financial Statement Audit.** If, during its fiscal year, Grantee expends less than \$1,000,000 in federal pass-through funds from State-issued Awards, Grantee must follow all of the audit requirements in Paragraphs 12.3(c)(i)-(v), above.

(d) **Publicly-Traded Entities.** If Grantee is a publicly-traded company, Grantee is not subject to the single audit or program-specific audit requirements, but must submit its annual audit conducted in accordance with its regulatory requirements.

12.5. **Performance of Audits.** For those organizations required to submit an independent audit report, the audit must be conducted by the Illinois Auditor General (as required for certain governmental entities only), or a Certified Public Accountant or Certified Public Accounting Firm licensed in the State of Illinois or in accordance with Section 5.2 of the Illinois Public Accounting Act (225 ILCS 450/5.2). For all audits required to be performed subject to GAGAS or Generally Accepted Auditing Standards, Grantee must request and maintain on file a copy of the auditor's most recent peer review report and acceptance letter. Grantee must follow procedures prescribed by Grantor for the preparation and submission of audit reports and any related documents.

12.6. **Delinquent Reports.** When audit reports or financial statements required under this ARTICLE are prepared by the Illinois Auditor General, if they are not available by the above-specified due date, they must be provided to Grantor within thirty (30) days of becoming available. Grantee should refer to the State Grantee Compliance Enforcement System for the policy and consequences for late reporting. 44 Ill. Admin. Code 7000.80.

### ARTICLE XIII TERMINATION; SUSPENSION; NON-COMPLIANCE

#### 13.1. Termination.

(a) Either Party may terminate this Agreement, in whole or in part, upon thirty (30) calendar days' prior written notice to the other Party.

(b) If terminated by the Grantee, Grantee must include the reasons for such termination, the effective date, and, in the case of a partial termination, the portion to be terminated. If Grantor determines in the case of a partial termination that the reduced or modified portion of the Award will not accomplish the purposes for which the Award was made, Grantor may terminate the Agreement in its entirety. 2 CFR 200.340(a)(3).

(c) This Agreement may be terminated, in whole or in part, by Grantor:

(i) Pursuant to a funding failure under Paragraph 4.1;

(ii) If Grantee fails to comply with the terms and conditions of this or any Award, application or proposal, including any applicable rules or regulations, or has made a false representation in connection with the receipt of this or any Award; or

(iii) If the Award no longer effectuates the Program goals or agency priorities and if this termination is permitted in the terms and conditions of the Award, which must be detailed in Exhibit A, PART TWO or PART THREE.

13.2. Suspension. Grantor may suspend this Agreement, in whole or in part, pursuant to a funding failure under Paragraph 4.1 or if the Grantee fails to comply with terms and conditions of this or any Award. If suspension is due to Grantee's failure to comply, Grantor may withhold further payment and prohibit Grantee from incurring additional Obligations pending corrective action by Grantee or a decision to terminate this Agreement by Grantor. Grantor may allow necessary and proper costs that Grantee could not reasonably avoid during the period of suspension.

13.3. Non-compliance. If Grantee fails to comply with the U.S. Constitution, applicable statutes, regulations or the terms and conditions of this or any Award, Grantor may impose additional conditions on Grantee, as described in 2 CFR 200.208. If Grantor determines that non-compliance cannot be remedied by imposing additional conditions, Grantor may take one or more of the actions described in 2 CFR 200.339. The Parties must follow all Grantor policies and procedures regarding non-compliance, including, but not limited to, the procedures set forth in the State Grantee Compliance Enforcement System. 44 Ill. Admin. Code 7000.80 and 7000.260.

13.4. Objection. If Grantor suspends or terminates this Agreement, in whole or in part, for cause, or takes any other action in response to Grantee's non-compliance, Grantee may avail itself of any opportunities to object and challenge such suspension, termination or other action by Grantor in accordance with any applicable processes and procedures, including, but not limited to, the procedures set forth in the State Grantee Compliance Enforcement System. 2 CFR 200.342; 44 Ill. Admin. Code 7000.80 and 7000.260.

13.5. Effects of Suspension and Termination.

(a) Grantor may credit Grantee for allowable expenditures incurred in the performance of authorized services under this Agreement prior to the effective date of a suspension or termination.

(b) Except as set forth in subparagraph (c), below, Grantee must not incur any costs or Obligations that require the use of Grant Funds after the effective date of a suspension or termination, and must cancel as many outstanding Obligations as possible.

(c) Costs to Grantee resulting from Obligations incurred by Grantee during a suspension or after termination of the Agreement are not allowable unless Grantor expressly authorizes them in the notice of suspension or termination or subsequently. However, Grantor may allow costs during a suspension or after termination if:

(i) The costs result from Obligations properly incurred before the effective date of suspension or termination, are not in anticipation of the suspension or termination, and the costs would be allowable if the Agreement was not suspended or terminated prematurely. 2 CFR 200.343.

13.6. Close-out of Terminated Agreements. If this Agreement is terminated, in whole or in part, the Parties must comply with all close-out and post-termination requirements of this Agreement. 2 CFR 200.340(d).

#### ARTICLE XIV SUBCONTRACTS/SUBAWARDS

14.1. Subcontracting/Subrecipients/Delegation. Grantee must not subcontract nor issue a subaward for any portion of this Agreement nor delegate any duties hereunder without Prior Approval of Grantor. The requirement for Prior Approval is satisfied if the subcontractor or subrecipient has been identified in the uniform grant application, such as, without limitation, a Project description, and Grantor has approved. Grantee must follow all applicable requirements set forth in 2 CFR 200.332.

14.2. Application of Terms. If Grantee enters into a subaward agreement with a subrecipient, Grantee must notify the subrecipient of the applicable laws and regulations and terms and conditions of this Award by attaching this Agreement to the subaward agreement. The terms of this Agreement apply to all subawards authorized in accordance with Paragraph 14.1. 2 CFR 200.101(b).

14.3. Liability as Guaranty. Grantee will be liable as guarantor for any Grant Funds it obligates to a subrecipient or subcontractor pursuant to this ARTICLE in the event Grantor determines the funds were either misspent or are being improperly held and the subrecipient or subcontractor is insolvent or otherwise fails to return the funds. 2 CFR 200.345; 30 ILCS 705/6; 44 Ill. Admin. Code 7000.450(a).

#### ARTICLE XV NOTICE OF CHANGE

15.1. Notice of Change. Grantee must notify Grantor if there is a change in Grantee's legal status, FEIN, UEI, SAM registration status, Related Parties, senior management (for non-governmental grantees only) or address. If the change is anticipated, Grantee must give thirty (30) days' prior written notice to Grantor. If the change is unanticipated, Grantee must give notice as soon as practicable thereafter. Grantor reserves the right to take any and all appropriate action as a result of such change(s).

15.2. Failure to Provide Notification. To the extent permitted by Illinois law (see Paragraph 21.2), Grantee must hold harmless Grantor for any acts or omissions of Grantor resulting from Grantee's failure to notify Grantor as required by Paragraph 15.1.

15.3. Notice of Impact. Grantee must notify Grantor in writing of any event, including, by not limited to, becoming a party to litigation, an investigation, or transaction that may have a material impact on Grantee's ability to perform under this Agreement. Grantee must provide notice to Grantor as soon as possible, but no later than five (5) days after Grantee becomes aware that the event may have a material impact.

15.4. Effect of Failure to Provide Notice. Failure to provide the notice described in this ARTICLE is grounds for termination of this Agreement and any costs incurred after the date notice should have been given may be disallowed.

#### ARTICLE XVI STRUCTURAL REORGANIZATION AND RECONSTITUTION OF BOARD MEMBERSHIP

16.1. Effect of Reorganization. This Agreement is made by and between Grantor and Grantee, as Grantee is currently organized and constituted. Grantor does not agree to continue this Agreement, or any license related thereto, should Grantee significantly reorganize or otherwise substantially change the character of its corporate structure, business structure or governance structure. Grantee must give Grantor prior notice of any such action or changes significantly affecting its overall structure or, for non-governmental grantees only, management makeup (for example, a merger or a corporate restructuring), and must provide all reasonable documentation necessary for Grantor to review the proposed transaction including financial records and corporate and shareholder minutes of any corporation which may be involved. Grantor reserves the right to terminate the Agreement based on whether the newly organized entity is able to carry out the requirements of the Award. This ARTICLE does not require Grantee to report on minor changes in the makeup of its board membership or

governance structure, as applicable. Nevertheless, **PART TWO** or **PART THREE** may impose further restrictions. Failure to comply with this ARTICLE constitutes a material breach of this Agreement.

#### ARTICLE XVII CONFLICT OF INTEREST

17.1. Required Disclosures. Grantee must immediately disclose in writing any potential or actual Conflict of Interest to Grantor. 2 CFR 200.112; 30 ILCS 708/35.

17.2. Prohibited Payments. Payments made by Grantor under this Agreement must not be used by Grantee to compensate, directly or indirectly, any person currently holding an elective office in this State including, but not limited to, a seat in the General Assembly. In addition, where Grantee is not an instrumentality of the State of Illinois, as described in this Paragraph, Grantee must request permission from Grantor to compensate, directly or indirectly, any officer or any person employed by an office or agency of the State of Illinois. An instrumentality of the State of Illinois includes, without limitation, State departments, agencies, boards, and State universities. An instrumentality of the State of Illinois does not include, without limitation, units of Local Government and related entities.

17.3. Request for Exemption. Grantee may request written approval from Grantor for an exemption from Paragraph 17.2. Grantee acknowledges that Grantor is under no obligation to provide such exemption and that Grantor may grant any such exemption subject to additional terms and conditions as Grantor may require.

#### ARTICLE XVIII EQUIPMENT OR PROPERTY

18.1. Purchase of Equipment. For any equipment purchased in whole or in part with Grant Funds, if Grantor determines that Grantee has not met the conditions of 2 CFR 200.439, the costs for such equipment will be disallowed. Grantor must notify Grantee in writing that the purchase of equipment is disallowed.

18.2. Prohibition against Disposition/Encumbrance. Any equipment, material, or real property that Grantee purchases or improves with Grant Funds must not be sold, transferred, encumbered (other than original financing) or otherwise disposed of during the Award Term without Prior Approval of Grantor unless a longer period is required in **PART TWO** or **PART THREE** and permitted by 2 CFR Part 200 Subpart D. Use or disposition of real property acquired or improved using Grant Funds must comply with the requirements of 2 CFR 200.311. Real property, equipment, and intangible property that are acquired or improved in whole or in part using Grant Funds are subject to the provisions of 2 CFR 200.316. Grantor may require the Grantee to record liens or other appropriate notices of record to indicate that personal or real property has been acquired or improved with this Award and that use and disposition conditions apply to the property.

18.3. Equipment and Procurement. Grantee must comply with the uniform standards set forth in 2 CFR 200.310–200.316 governing the management and disposition of property, the cost of which was supported by Grant Funds. Any waiver from such compliance must be granted by either the President’s Office of Management and Budget, the Governor’s Office of Management and Budget, or both, depending on the source of the Grant Funds used. Additionally, Grantee must comply with the standards set forth in 2 CFR 200.317-200.327 to establish procedures to use Grant Funds for the procurement of supplies and other expendable property, equipment, real property and other services.

18.4. Equipment Instructions. Grantee must obtain disposition instructions from Grantor when equipment, purchased in whole or in part with Grant Funds, is no longer needed for their original purpose. Notwithstanding anything to the contrary contained in this Agreement, Grantor may require transfer of any equipment to Grantor or a third party for any reason, including, without limitation, if Grantor terminates the

Award or Grantee no longer conducts Award activities. Grantee must properly maintain, track, use, store and insure the equipment according to applicable best practices, manufacturer's guidelines, federal and state laws or rules, and Grantor requirements stated herein.

18.5. Domestic Preferences for Procurements. In accordance with 2 CFR 200.322, to the greatest extent practicable and consistent with law, Grantee must, under this Award, provide a preference for the purchase, acquisition, or use of goods, products, or materials produced in the United States (including but not limited to iron, aluminum, steel, cement, and other manufactured products). The requirements of this Paragraph must be included in all subawards and in all contracts and purchase orders under this Award.

#### **ARTICLE XIX PROMOTIONAL MATERIALS; PRIOR NOTIFICATION**

19.1. Promotional and Written Materials. Use of Grant Funds for promotions is subject to the prohibitions for advertising or public relations costs in 2 CFR 200.421(e). To use Grant Funds in whole or in part to produce any written publications, announcements, reports, flyers, brochures or other written materials, these uses must be allowable under 2 CFR 200.421 and 200.467 and Grantee must include in these publications, announcements, reports, flyers, brochures and all other such material, the phrase "Funding provided in whole or in part by the [Grantor]." 2 CFR 200.467. Exceptions to this requirement must be requested, in writing, from Grantor and will be considered authorized only upon written notice thereof to Grantee.

19.2. Prior Notification/Release of Information. Grantee must notify Grantor ten (10) days prior to issuing public announcements or press releases concerning work performed pursuant to this Agreement, or funded in whole or in part by this Agreement, and must cooperate with Grantor in joint or coordinated releases of information.

#### **ARTICLE XX INSURANCE**

20.1. Maintenance of Insurance. Grantee must maintain in full force and effect during the Term of this Agreement casualty and bodily injury insurance, as well as insurance sufficient to cover the replacement cost of any and all real or personal property (including equipment), or both, purchased or, otherwise acquired, or improved in whole or in part, with funds disbursed pursuant to this Agreement. 2 CFR 200.310. Additional insurance requirements may be detailed in **PART TWO** or **PART THREE**.

20.2. Claims. If a claim is submitted for real or personal property, or both, purchased in whole with funds from this Agreement and such claim results in the recovery of money, such money recovered must be surrendered to Grantor.

#### **ARTICLE XXI LAWSUITS AND INDEMNIFICATION**

21.1. Independent Contractor. Neither Grantee nor any employee or agent of Grantee acquires any employment rights with Grantor by virtue of this Agreement. Grantee must provide the agreed services and achieve the specified results free from the direction or control of Grantor as to the means and methods of performance. Grantee must provide its own equipment and supplies necessary to conduct its business; provided, however, that in the event, for its convenience or otherwise, Grantor makes any such equipment or supplies available to Grantee, Grantee's use of such equipment or supplies provided by Grantor pursuant to this Agreement is strictly limited to official Grantor or State of Illinois business and not for any other purpose, including any personal benefit or gain.

21.2. Indemnification and Liability.

(a) Non-governmental entities. This subparagraph applies only if Grantee is a non-governmental entity. Grantee must hold harmless Grantor against any and all liability, loss, damage, cost or expenses, including attorneys' fees, arising from the intentional torts, negligence or breach of contract of Grantee, with the exception of acts performed in conformance with an explicit, written directive of Grantor. Indemnification by Grantor is governed by the State Employee Indemnification Act (5 ILCS 350/.01 et seq.) as interpreted by the Illinois Attorney General. Grantor makes no representation that Grantee, an independent contractor, will qualify or be eligible for indemnification under said Act.

(b) Governmental entities. This subparagraph applies only if Grantee is a governmental unit as designated in Paragraph 3.2. Neither Party shall be liable for actions chargeable to the other Party under this Agreement including, but not limited to, the negligent acts and omissions of the other Party's agents, employees or subcontractors in the performance of their duties as described under this Agreement, unless such liability is imposed by law. This Agreement is not construed as seeking to enlarge or diminish any obligation or duty owed by one Party against the other or against a third party.

**ARTICLE XXII  
MISCELLANEOUS**

22.1. Gift Ban. Grantee is prohibited from giving gifts to State employees pursuant to the State Officials and Employees Ethics Act (5 ILCS 430/10-10) and Illinois Executive Order 15-09.

22.2. Assignment Prohibited. This Agreement must not be sold, assigned, or transferred in any manner by Grantee, to include an assignment of Grantee's rights to receive payment hereunder, and any actual or attempted sale, assignment, or transfer by Grantee without the Prior Approval of Grantor in writing renders this Agreement null, void and of no further effect.

22.3. Copies of Agreements upon Request. Grantee must, upon request by Grantor, provide Grantor with copies of contracts or other agreements to which Grantee is a party with any other State agency.

22.4. Amendments. This Agreement may be modified or amended at any time during its Term by mutual consent of the Parties, expressed in writing and signed by the Parties.

22.5. Severability. If any provision of this Agreement is declared invalid, its other provisions will remain in effect.

22.6. No Waiver. The failure of either Party to assert any right or remedy pursuant to this Agreement will not be construed as a waiver of either Party's right to assert such right or remedy at a later time or constitute a course of business upon which either Party may rely for the purpose of denial of such a right or remedy.

22.7. Applicable Law; Claims. This Agreement and all subsequent amendments thereto, if any, are governed and construed in accordance with the laws of the State of Illinois. Any claim against Grantor arising out of this Agreement must be filed exclusively with the Illinois Court of Claims. 705 ILCS 505/1 et seq. Grantor does not waive sovereign immunity by entering into this Agreement.

22.8. Compliance with Law. Grantee is responsible for ensuring that Grantee's Obligations and services hereunder are performed in compliance with all applicable federal and State laws, including, without limitation, federal regulations, State administrative rules, including but not limited to 44 Ill. Admin. Code Part 7000, laws and rules which govern disclosure of confidential records or other information obtained by Grantee concerning persons served under this Agreement, and any license requirements or professional certification provisions.

22.9. Compliance with Freedom of Information Act. Upon request, Grantee must make available to Grantor all documents in its possession that Grantor deems necessary to comply with requests made under the Freedom of Information Act. 5 ILCS 140/7(2).

22.10 Compliance with Whistleblower Protections. Grantee must comply with the Whistleblower Act (740 ILCS 174/1 *et seq.*) and the whistleblower protections set forth in 2 CFR 200.217, including but not limited to, the requirement that Grantee and its subrecipients inform their employees in writing of employee whistleblower rights and protections under 41 U.S.C. 4712.

22.11. Precedence.

(a) Except as set forth in subparagraph (b), below, the following rules of precedence are controlling for this Agreement: In the event there is a conflict between this Agreement and any of the exhibits or attachments hereto, this Agreement controls. In the event there is a conflict between **PART ONE** and **PART TWO** or **PART THREE** of this Agreement, **PART ONE** controls. In the event there is a conflict between **PART TWO** and **PART THREE** of this Agreement, **PART TWO** controls. In the event there is a conflict between this Agreement and relevant statute(s) or rule(s), the relevant statute(s) or rule(s) controls.

(b) Notwithstanding the provisions in subparagraph (a), above, if a relevant federal or state statute(s) or rule(s) requires an exception to this Agreement's provisions, or an exception to a requirement in this Agreement is granted by GATU, such exceptions must be noted in **PART TWO** or **PART THREE**, and in such cases, those requirements control.

22.12. Illinois Grant Funds Recovery Act. In the event of a conflict between the Illinois Grant Funds Recovery Act and the Grant Accountability and Transparency Act, the provisions of the Grant Accountability and Transparency Act control. 30 ILCS 708/80.

22.13. Headings. Articles and other headings contained in this Agreement are for reference purposes only and are not intended to define or limit the scope, extent or intent of this Agreement or any provision hereof.

22.14. Counterparts. This Agreement may be executed in one or more counterparts, each of which are considered to be one and the same agreement, binding on all Parties hereto, notwithstanding that all Parties are not signatories to the same counterpart. Duplicated signatures, signatures transmitted via facsimile, or signatures contained in a Portable Document Format (PDF) document are deemed original for all purposes.

22.15. Attorney Fees and Costs. Unless prohibited by law, if Grantor prevails in any proceeding to enforce the terms of this Agreement, including any administrative hearing pursuant to the Grant Funds Recovery Act or the Grant Accountability and Transparency Act, Grantor has the right to recover reasonable attorneys' fees, costs and expenses associated with such proceedings.

22.16. Continuing Responsibilities. The termination or expiration of this Agreement does not affect: (a) the right of Grantor to disallow costs and recover funds based on a later audit or other review; (b) the obligation of the Grantee to return any funds due as a result of later refunds, corrections or other transactions, including, without limitation, final Indirect Cost Rate adjustments and those funds obligated pursuant to ARTICLE XIV; (c) the CYEFR(s); (d) audit requirements established in 44 Ill. Admin. Code 7000.90 and ARTICLE XII ; (e) property management and disposition requirements established in 2 CFR 200.310 through 2 CFR 200.316 and ARTICLE XVIII; or (f) records related requirements pursuant to ARTICLE IX. 44 Ill. Admin. Code 7000.440.

**THE REMAINDER OF THIS PAGE IS INTENTIONALLY LEFT BLANK.**

**EXHIBIT A**

**PROJECT DESCRIPTION**

Grantee must complete the Award Activities described on this **Exhibit A**, the Deliverables and Milestones listed on **Exhibit B** and the Performance Measures listed on **Exhibit D** within the term of this Agreement, as provided in Paragraph 2.1, herein.

**AUTHORITY:** The Grantor is authorized to make this Award pursuant to 20 ILCS 605/605-55 and/or 20 ILCS 605/605-30.

The purpose of this authority is as follows:

To make and enter into contracts, including grants, as authorized pursuant to appropriations by the General Assembly. and/or to use the State and federal programs, grants, and subsidies that are available to assist in the discharge of the provisions of the Civil Administrative Code of Illinois.

**PROJECT DESCRIPTION:**

**SCOPE OF WORK**

Grant funds will be utilized for a portion of the costs, including any that are prior incurred, associated with roadway improvements along the Grantee owned streets of Birch Street (Touhy to the dead end, north), Prairie Avenue (5<sup>th</sup> Street to 2<sup>nd</sup> Street), and Halsey Drive (Scott Street to Craig Drive) in the City of Des Plaines

The completion of this project will benefit approximately 250 residents along the areas to be improved, but it will benefit thousands of residents and businesses by providing safe and reliable drainage and roadways.

**PROJECT WORK PLAN**

The Grantee shall administer the project as outlined in the Grantee’s Project Work Plan approved by the Grantor. The Project Work Plan may be modified with Grantor approval throughout the Term of this Agreement. The Project Work Plan, once approved by Grantor, and any modifications thereto, are incorporated fully by reference into this Agreement.

**EXHIBIT B**

**DELIVERABLES OR MILESTONES**

To be stated on the initial submitted Periodic Performance Report (PPR), as directed by the Report Deliverable Schedule, the Grantee will provide a detailed task list of projected deliverables, which must be approved by Grantor. These tasks and associated due dates, and any subsequent revisions, shall be incorporated by reference into this Agreement. These tasks will be used to measure performance throughout the life of the Award and can be updated and reported on each PPR reporting due date.

EXHIBIT C

CONTACT INFORMATION

**CONTACTS FOR NOTIFICATION AND GRANT ADMINISTRATION:**

Unless specified elsewhere, all notices required or desired to be sent by either Party must be sent to the persons listed below. Grantee must notify Grantor of any changes in its contact information listed below within five (5) business days from the effective date of the change, and Grantor must notify Grantee of any changes to its contact information as soon as practicable. The Party making a change must send any changes in writing to the contact for the other Party. No amendment to this Agreement is required if information in this Exhibit is changed.

**FOR OFFICIAL GRANT NOTIFICATIONS**

**GRANTOR CONTACT**

Name: Kristin A. Richards  
Title: Director  
Address: 1011 S. 2<sup>nd</sup> St.  
Springfield, IL 62704

**GRANTEE CONTACT**

Name: Dorothy Wisniewski  
Title: City Manager  
Address: 1420 MINER ST  
Des Plaines, IL 60016-4484

**GRANTEE PAYMENT ADDRESS**

(If different than the address above)

Address: N/A

**FOR GRANT ADMINISTRATION**

**GRANTOR CONTACT**

Name: Tammy Greco  
Title: Grant Manager  
Address: 1011 S. 2<sup>nd</sup> St.  
Springfield, IL 62704  
Phone: 217-785-9974  
TTY#: (800) 785-6055  
Email: tammy.m.greco@illinois.gov  
Address:

**GRANTEE CONTACT**

Name: Becka Shipp  
Title: Assistant Director  
Address: 1420 MINER ST  
Des Plaines, IL 60016-4484  
Phone: 847-391-5388  
TTY#: N/A  
Email: bshipp@desplainesil.gov  
Address:

**GRANTEE DESIGNEES**

The following are designated as Authorized Designee(s) for the Grantee (See **PART TWO**, ARTICLE XXIII):

Authorized Designee: Timothy Watkins  
Authorized Designee Title: Director of Public Works and Engineering  
Authorized Designee Phone: 847-391-5390  
Authorized Designee Email: twatkins@desplainesil.gov

Authorized Designee Signature: \_\_\_\_\_

Authorized Signatory Approval: \_\_\_\_\_

Authorized Designee: Becka Shipp  
Authorized Designee Title: Assistant Director of Engineering  
Authorized Designee Phone: 847-391-5388  
Authorized Designee Email: bshipp@desplainesil.gov

Authorized Designee Signature: \_\_\_\_\_

Authorized Signatory Approval: \_\_\_\_\_

Authorized Designee: \_\_\_\_\_  
Authorized Designee Title: \_\_\_\_\_  
Authorized Designee Phone: \_\_\_\_\_  
Authorized Designee Email: \_\_\_\_\_

Authorized Designee Signature: \_\_\_\_\_

Authorized Signatory Approval: \_\_\_\_\_

Authorized Designee: \_\_\_\_\_  
Authorized Designee Title: \_\_\_\_\_  
Authorized Designee Phone: \_\_\_\_\_  
Authorized Designee Email: \_\_\_\_\_

Authorized Designee Signature: \_\_\_\_\_

Authorized Signatory Approval: \_\_\_\_\_

**GRANTOR CONTACT FOR AUDIT OR CONSOLIDATED YEAR-END FINANCIAL REPORTS QUESTIONS—AUDIT UNIT**

Email: [CEO.GrantHelp@Illinois.gov](mailto:CEO.GrantHelp@Illinois.gov)

**GRANTOR CONTACT FOR FINANCIAL CLOSEOUT AND REFUNDS—PROGRAM ACCOUNTANT**

Name: Salma Larhouti  
Email: salma.larhouti@illinois.gov  
Phone: 000-000-0000  
Fax#: N/A

Address: IDCEO-ACCOUNTING OFFICE  
1011 S 2ND ST  
SPRINGFIELD IL 62704-3004

**EXHIBIT D**

**PERFORMANCE MEASURES AND STANDARDS**

To be stated on the initial submitted Periodic Performance Report (PPR), as directed by the Report Deliverable Schedule, the Grantee will incorporate project specific performance measures within the corresponding section of the PPR. The project specific performance measures will encompass the following standardized performance measures listed below.

- Did the deliverables specified in the task list submitted pursuant to Exhibit B lead to the completion of the project described in Exhibit A?
- Given the total amount of Grant Funds available, does the percent currently drawn and expended directly correlate to the percent of the completion of the project to date?
- At the time of Award closeout, has the Grantee fulfilled the public purpose of the project stated in Exhibit A?

The Grantor reserves the right to deny any voucher request(s) at its discretion, based on lack of progress toward meeting completion goals. If the Grantee fails to meet any of the performance measures/goals, and if deemed appropriate at the discretion of the Grantor, the Grant Funds may be decreased by an amount proportionate to the size of the shortfall, and/or the Grantee may be responsible for the return of the Grant Funds in the amount specified by the Grantor. Grantor may initiate a grant modification(s) to de-obligate Grant Funds based on non-performance. The Grantee will submit grant modification requests as necessary in a timely manner, including a request to de-obligate Grant Funds in an amount that the Grantee determines will be unspent by the end of the Grant Agreement Term.

**EXHIBIT E**

**SPECIFIC CONDITIONS**

Grantor may remove (or reduce) a Specific Condition included in this Exhibit by providing written notice to the Grantee, in accordance with established procedures for removing a Specific Condition.

There were no conditions resulting from the Internal Control Questionnaire (ICQ).

There were no conditions resulting from the Programmatic Risk Assessment.

**PART TWO – GRANTOR-SPECIFIC TERMS**

In addition to the uniform requirements in **PART ONE**, Grantor has the following additional requirements for its Grantee:

**ARTICLE XXIII  
AUTHORIZED SIGNATORY**

23.1. Authorized Signatory. In processing this Award and related documentation, Grantor will only accept materials signed by the Authorized Signatory or Designee of this Agreement, as designated or prescribed in the Grantee's signature block or on **Exhibit C**. If the Authorized Signatory chooses to assign a designee to sign or submit materials required by this Agreement to Grantor, the Authorized Signatory must either send written notice to Grantor indicating the name of the designee, or provide notice as set forth in **Exhibit C**. Without this notice, Grantor will reject any materials signed or submitted on the Grantee's behalf by anyone other than the Authorized Signatory. The Authorized Signatory must approve each Authorized Designee separately by signing as indicated on **Exhibit C** or on the appropriate form provided by Grantor. If an Authorized Designee(s) appears on **Exhibit C**, the Grantee should verify the information and indicate any changes as necessary. Signatures of both the Authorized Signatory and the Authorized Designee are required in order for the Authorized Designee to have signature authority under this Agreement.

**ARTICLE XXIV  
ADDITIONAL AUDIT PROVISIONS**

24.1. Discretionary Audit. The Grantor may, at any time and in its sole discretion, require a program-specific audit, or other audit, SAS 115/AU-C265 letters (Auditor's Communication of Internal Control Related Matters) and SAS 114/AU-C260 letters (Auditor's Communication With Those Charged With Governance).

**ARTICLE XXV  
ADDITIONAL MONITORING PROVISIONS**

25.1. Cooperation with Audits and Inquiries, Confidentiality. Pursuant to ARTICLE IX, above, the Grantee is obligated to cooperate with the Grantor and other legal authorities in any audit or inquiry related to the Award. The Grantor or any other governmental authority conducting an audit or inquiry may require the Grantee to keep confidential any audit or inquiry and to limit internal disclosure of the audit or inquiry to those Grantee personnel who are necessary to support the Grantee's response to the audit or inquiry. This confidentiality requirement does not limit Grantee's right to discuss an audit or inquiry with its legal counsel. If a third party seeks to require the Grantee, pursuant to any law, regulation, or legal process, to disclose an audit or inquiry that has been deemed confidential by the Grantor or other governmental authority, the Grantee must promptly notify the entity that is conducting the audit or inquiry of such effort so that the entity that is conducting the audit or inquiry may seek a protective order, take other appropriate action, or waive compliance by the Grantee with the confidentiality requirement.

**ARTICLE XXVI  
ADDITIONAL INTEREST PROVISIONS**

26.1. Interest Earned on Grant Funds. Interest earned on Grant Funds in an amount up to \$500 per year may be retained by the Grantee for administrative expenses unless otherwise provided in **PART THREE**. Any additional interest earned on Grant Funds above \$500 per year must be returned to the Grantor pursuant to Paragraphs 4.3 and 29.2 herein, or as otherwise instructed by the Grant Manager or as set forth in **PART THREE**. All interest earned must be expended prior to Grant Funds. Any unspent Grant Funds or earned interest unspent must be returned as Grant Funds to the Grantor as described in Paragraphs 4.3 and 29.2 herein. All interest earned on Grant Funds must be accounted for and reported to the Grantor as provided in ARTICLE X herein. If applicable, the Grantor will remit interest earned and returned by Grantee to the U.S. Department of Health and Human Services

Payment Management System through the process set forth at 2 CFR 200.305(b)(12), or as otherwise directed by the federal awarding agency. The provisions of this Paragraph are inapplicable to the extent any statute, rule or program requirement provides for different treatment of interest income. Any provision that deviates from this paragraph is set forth in **PART THREE**.

**ARTICLE XXVII  
ADDITIONAL BUDGET PROVISIONS**

27.1. Restrictions on Line Item Transfers. Unless set forth otherwise in **PART THREE** herein, Budget line item transfers within the guidelines set forth in paragraph 6.2 herein, which would not ordinarily require approval from Grantor, but result in an increase of ten percent (10%) or more to any expenditure category of the current approved Budget, are considered changes in the project scope and require Prior Approval from Grantor pursuant to 44 Ill. Admin. Code 7000.370(b).

**ARTICLE XXVIII  
ADDITIONAL REPRESENTATIONS AND WARRANTIES**

28.1. Grantee Representations and Warranties. In connection with the execution and delivery of this Agreement, the Grantee makes the following representations and warranties to Grantor:

(a) That it has no public or private interest, direct or indirect, and will not acquire, directly or indirectly any such interest which does or may conflict in any manner with the performance of the Grantee's services and obligations under this Agreement;

(b) That no member of any governing body or any officer, agent or employee of the State, has a personal financial or economic interest directly in this Agreement, or any compensation to be paid hereunder except as may be permitted by applicable statute, regulation or ordinance;

(c) That there is no action, suit or proceeding at law or in equity pending, nor to the best of Grantee's knowledge, threatened, against or affecting the Grantee, before any court or before any governmental or administrative agency, which will have a material adverse effect on the performance required by this Agreement;

(d) That to the best of the Grantee's knowledge and belief, the Grantee, its principals and key project personnel:

(i) Are not presently declared ineligible or voluntarily excluded from contracting with any federal or State department or agency;

(ii) Have not, within a three (3)-year period preceding this Agreement, been convicted of any felony; been convicted of a criminal offense in connection with obtaining, attempting to obtain, or performing a public (federal, state, or local) transaction or contract under a public transaction; had a civil judgment rendered against them for commission of fraud; been found in violation of federal or state antitrust statutes; or been convicted of embezzlement, theft, larceny, forgery, bribery, falsification or destruction of records, making a false statement, or receiving stolen property;

(iii) Are not presently indicted for, or otherwise criminally or civilly charged, by a government entity (federal, state or local) with commission of any of the offenses enumerated in subparagraph (ii) of this certification; and

(iv) Have not had, within a three (3)-year period preceding this Agreement, any judgment rendered in an administrative, civil or criminal matter against the Grantee, or any entity

associated with its principals or key personnel, related to a grant issued by any federal or state agency or a local government.

Any request for an exception to the provisions of this subparagraph (d) must be made in writing, listing the name of the individual, home address, type of conviction and date of conviction; and

(e) Grantee certifies that it is not currently operating under, or subject to, any cease and desist order, or subject to any informal or formal regulatory action, and, to the best of Grantee's knowledge, that it is not currently the subject of any investigation by any state or federal regulatory, law enforcement or legal authority. Should it become the subject of an investigation by any state or federal regulatory, law enforcement or legal authority, Grantee shall promptly notify Grantor of any such investigation. Grantee acknowledges that should it later be subject to a cease and desist order, Memorandum of Understanding, or found in violation pursuant to any regulatory action or any court action or proceeding before any administrative agency, that Grantor is authorized to declare Grantee out of compliance with this Agreement and suspend or terminate the Agreement pursuant to ARTICLE XIII herein and any applicable rules.

#### ARTICLE XXIX

#### ADDITIONAL TERMINATION, SUSPENSION, BILLING SCHEDULE AND NON-COMPLIANCE PROVISIONS

29.1. Remedies for Non-Compliance. If Grantor suspends or terminates this Agreement pursuant to ARTICLE XIII herein, Grantor may also elect any additional remedy allowed by law, including, but not limited to, one or more of the following remedies:

(a) Direct the Grantee to refund some or all of the Grant Funds disbursed to it under this Agreement; and

(b) Direct the Grantee to remit an amount equivalent to the "Net Salvage Value" of all equipment or materials purchased with Grant Funds provided under this Agreement. For purposes of this Agreement, "Net Salvage Value" is defined as the amount realized, or that the Parties agree is likely to be realized from, the sale of equipment or materials purchased with Grant Funds provided under this Agreement at its current fair market value, less selling expenses.

29.2. Grant Refunds. In accordance with the Illinois Grant Funds Recovery Act, 30 ILCS 705/1 *et seq.*, the Grantee must, within forty-five (45) days of the effective date of a termination of this Agreement, refund to Grantor, any balance of Grant Funds not spent or not obligated as of that date.

29.3. Grant Funds Recovery Procedures. In the event that Grantor seeks to recover from Grantee Grant Funds received pursuant to this Award that: (i) Grantee cannot demonstrate were properly spent, or (ii) have not been expended or legally obligated by the time of expiration or termination of this Award, the Parties agree to follow the procedures set forth in the Illinois Grant Funds Recovery Act, 30 ILCS 705/1 *et seq.* (GFRA), for the recovery of Grant Funds, including the informal and formal hearing requirements. All remedies available in Section 6 of the GFRA will apply to these proceedings. The Parties agree that Grantor's Administrative Hearing Rules (56 Ill. Admin. Code Part 2605) and/or any other applicable hearing rules shall govern these proceedings.

29.4. Grantee Responsibility. Grantee will be held responsible for the expenditure of all Grant Funds received through this Award, whether expended by Grantee or a subrecipient or contractor of Grantee. Grantor may seek any remedies against Grantee permitted pursuant to this Agreement and 2 CFR 200.339 for the action of a subrecipient or contractor of Grantee that is not in compliance with the applicable statutes, regulations or the terms and conditions of this Award.

29.5. Billing Schedule. In accordance with paragraph 4.8, herein Grantee must submit all payment requests to Grantor within thirty (30) days of the end of the quarter, unless another billing schedule is specified in **PART THREE** or Paragraph 2.3. Failure to submit such payment request timely will render the amounts billed an

unallowable cost which Grantor cannot reimburse. In the event that Grantee is unable, for good cause, to submit its payment request timely, Grantee must timely notify Grantor and may request an extension of time to submit the payment request. Grantor's approval of Grantee's request for an extension cannot be unreasonably withheld. The payment requirements of this Paragraph supersede those set forth in Paragraph 4.8.

**ARTICLE XXX**  
**ADDITIONAL MODIFICATION PROVISIONS**

30.1. Modifications by Operation of Law. This Agreement is subject to such modifications as the Grantor determines, in its sole discretion, may be required by changes in federal or State law or regulations applicable to this Agreement. Grantor will initiate such modifications, and Grantee will be required to agree to the modification in writing as a condition of continuing the Award. Any such required modification will be incorporated into and become part of this Agreement as if fully set forth herein. The Grantor will timely notify the Grantee of any pending implementation of or proposed amendment to any laws or regulations of which it has notice.

30.2. Discretionary Modifications. If either the Grantor or the Grantee wishes to modify the terms of this Agreement other than as set forth in ARTICLES V and VI and Paragraphs 30.1 and 30.3, written notice of the proposed modification must be given to the other Party. Modifications will only take effect when agreed to in writing by both the Grantor and the Grantee. However, if the Grantor notifies the Grantee in writing of a proposed modification, and the Grantee fails to respond to that notification, in writing, within thirty (30) days, the Grantor may commence a process to suspend or terminate this Award. In making an objection to the proposed modification, the Grantee must specify the reasons for the objection and the Grantor will consider those objections when evaluating whether to follow through with the proposed modification. The Grantor's notice to the Grantee must contain the Grantee name, Agreement number, Amendment number and purpose of the revision. If the Grantee seeks any modification to the Agreement, the Grantee must submit a detailed narrative explaining why the Project cannot be completed in accordance with the terms of the Agreement and how the requested modification will ensure completion of the Grant Activities, Deliverables, Milestones and/or Performance Measures (Exhibits A, B and D).

30.3. Unilateral Modifications. The Parties agree that Grantor may, in its sole discretion, unilaterally modify this Agreement without prior approval of the Grantee when the modification is initiated by Grantor for the sole purpose of increasing the Grantee's funding allocation as additional funds become available for the Award during the program year covered by the Term of this Agreement.

30.4. Management Waiver. The Parties agree that the Grantor may issue a waiver of specific requirements of this Agreement after the term of the Agreement has expired. These waivers are limited to non-material changes to specific provisions that the Grantor determines are necessary to place the Grantee in administrative compliance with the requirements of this Agreement. A management waiver issued after the Term of the Agreement has expired will supersede the original requirements of this Agreement that would normally require a modification of this Agreement to be executed. The Grantor will make no modifications of this Agreement not agreed to prior to the expiration of the Agreement beyond what is specifically set forth in this Paragraph.

30.5. Term Extensions. The Grantee acknowledges that all Grant Funds must be expended or legally obligated, and all Grant Activities, Deliverables, Milestones and Performance Measures (Exhibits A, B and D) must be completed during the Term of the Agreement. Extensions of the Term will be granted only for good cause, subject to the Grantor's discretion. Pursuant to the Grant Funds Recovery Act (30 ILCS 705/1 *et seq.*), no Award may be extended in total beyond a two (2)-year period unless the Grant Funds are expended or legally obligated during that initial two-year period, or unless Grant Funds are disbursed for reimbursement of costs previously incurred by the Grantee. If Grantee requires an extension of the Award Term, Grantee should submit a written request to the Grant Manager at least sixty (60) days prior to the end of the Award Term or extended Award Term, as applicable, stating the reason for the extension. If Grantee provides reasonable extenuating circumstances, Grantee may request an extension of the Award Term with less than sixty (60) days remaining.

**ARTICLE XXXI  
ADDITIONAL CONFLICT OF INTEREST PROVISIONS**

31.1. Bonus or Commission Prohibited. The Grantee shall not pay any bonus or commission for the purpose of obtaining the Grant Funds awarded under this Agreement.

**ARTICLE XXXII  
ADDITIONAL EQUIPMENT OR PROPERTY PROVISIONS**

32.1. Equipment Management. The Grantee is responsible for replacing or repairing equipment and materials purchased with Grant Funds that are lost, stolen, damaged, or destroyed. Any loss, damage or theft of equipment and materials must be investigated and fully documented, and immediately reported to the Grantor and, where appropriate, the appropriate law enforcement authorities.

32.2. Purchase of Real Property. If permitted by the Award Budget and scope of activities provided in this Agreement, a Grantee may use the Grant Funds during the Award Term for the costs associated with the purchase of real property (as defined by 2 CFR 200.1) either through the use of reimbursement or advanced funds as permitted in Paragraph 2.3 of this Agreement for the following purposes and consistent with the Grantor's bondability guidelines and 2 CFR 200:

- (a) Cash payment of the entirety or a portion of the real property acquisition;
- (b) Cash Payment of a down payment for the acquisition;
- (c) Standard and commercially reasonable costs required to be paid at the acquisition closing (*i.e.*, closing costs); or
- (d) Payments to reduce the debt incurred by Grantee to purchase the real property.

32.3. Bonding Requirements. If Grant Funds through this Award are used for construction or facility improvement projects that exceed the Simplified Acquisition Threshold, the Grantee must comply with the minimum bonding requirements listed in 2 CFR 200.326(a) – (c). Grantor will not accept the Grantee's own bonding policy and requirements.

32.4. Lien Requirements. Grantor may direct Grantee in writing to record a lien or notice of State or federal interest on the property purchased or improved with Grant Funds. 2 CFR 200.316. If Grantor makes this direction and the Grantee does not comply, the Grantor may: (a) record the lien or notice of State or federal interest and reduce the amount of the Grant Funds by the cost of recording the lien or notice of State or federal interest, or (b) suspend this Award until Grantee complies with Grantor's direction.

**ARTICLE XXXIII  
APPLICABLE STATUTES**

To the extent applicable, Grantor and Grantee shall comply with the following:

33.1. Land Trust Beneficial Interest Disclosure Act (765 ILCS 405/2.1). No Grant Funds will be paid to any trustee of a land trust, or any beneficiary or beneficiaries of a land trust, for any purpose relating to the land, which is the subject of such trust, any interest in such land, improvements to such land or use of such land unless an affidavit is first filed with the Grantor identifying each beneficiary of the land trust by name and address and defining such interest therein. This affidavit must be filed with the Illinois Office of the Comptroller as an attachment to this Agreement.

33.2. Historic Preservation Act (20 ILCS 3420/1 et seq.). The Grantee will not expend Grant Funds under this Agreement which result in the destruction, alteration, renovation, transfer or sale, or utilization of a historic property, structure or structures, or in the introduction of visual, audible or atmospheric elements to a historic property, structure or structures, which will result in the change in the character or use of any historic property, except as approved by the Illinois Department of Natural Resources, Historic Preservation Division. The Grantee must not expend Grant Funds under this Agreement for any project, activity, or program that can result in changes in the character or use of historic property, if any historic property is located in the area of potential effects without the approval of the Illinois Department of Natural Resources, Historic Preservation Division. 20 ILCS 3420/3(f).

33.3. Victims' Economic Security and Safety Act (820 ILCS 180 et seq.). If the Grantee has one (1) or more employees, it may not discharge or discriminate against an employee who is a victim of domestic or sexual violence, or who has a family or household member who is a victim of domestic or sexual violence, for taking up to the allowable amount of leave from work to address the domestic violence, pursuant to the Victims' Economic Security and Safety Act. 820 ILCS 180/20(a)(2). The Grantee is not required to provide paid leave under the Victims' Economic Security and Safety Act, but may not suspend group health plan benefits during the leave period. Any failure on behalf of the Grantee to comply with all applicable provisions of the Victims' Economic Security and Safety Act, or applicable rules and regulations promulgated thereunder, may result in a determination that the Grantee is ineligible for future contracts or subcontracts with the State of Illinois or any of its political subdivisions or municipal corporations, and this Agreement may be cancelled or voided in whole or in part, and such other sanctions or penalties may be imposed or remedies invoked, as provided by statute or regulation.

33.4. Equal Pay Act of 2003 (820 ILCS 112 et seq.). If the Grantee has one (1) or more employees, it is prohibited by the Equal Pay Act of 2003 from: (a) discriminating between employees by paying unequal wages on the basis of sex for doing the same or substantially similar work; (b) discriminating between employees by paying wages to an African-American employee at a rate less than the rate at which the Grantee pays wages to another employee who is not African-American for the same or substantially similar work; (c) remedying violations of the Equal Pay Act of 2003 by reducing the wages of other employees or discriminating against any employee exercising their rights under the Equal Pay Act of 2003; and (d) screening job applicants based on their current or prior wages or salary histories, or requesting or requiring a wage or salary history from an individual as a condition of employment or consideration for employment. Any failure on behalf of the Grantee to comply with all applicable provisions of the Equal Pay Act of 2003, or applicable rules and regulations promulgated thereunder, may result in a determination that the Grantee is ineligible for future contracts or subcontracts with the State of Illinois or any of its political subdivisions or municipal corporations, and this Agreement may be cancelled or voided in whole or in part, and such other sanctions or penalties may be imposed or remedies invoked, as provided by statute or regulation.

33.5. Steel Products Procurement Act (30 ILCS 565/1 et seq.). The Grantee, if applicable, hereby certifies that any steel products used or supplied in accordance with this Award for a public works project shall be manufactured or produced in the United States per the requirements of the Steel Products Procurement Act (30 ILCS 565/1 et seq.).

33.6. Business Enterprise for Minorities, Women, and Persons with Disabilities Act and Illinois Human Rights Act (30 ILCS 575/0.01; 775 ILCS 5/2-105). The Grantee acknowledges and hereby certifies compliance with the provisions of the Business Enterprise for Minorities, Women, and Persons with Disabilities Act, and the equal employment practices of Section 2-105 of the Illinois Human Rights Act for the provision of services which are directly related to the Award activities to be performed under this Agreement.

33.7. Identity Protection Act (5 ILCS 179/1 et seq.) and Personal Information Protection Act (815 ILCS 530/1 et seq.). The Grantor is committed to protecting the privacy of its vendors, grantees and beneficiaries of programs and services. At times, the Grantor will request social security numbers or other personal identifying information. Federal and state laws, rules and regulations require the collection of this information for certain purposes relating to employment and/or payments for goods and services, including, but not limited to, Awards. The Grantor also collects confidential information for oversight and monitoring purposes.

Furnishing personal identity information, such as a social security number, is voluntary; however, failure to provide required personal identity information may prevent an individual or organization from using the services/benefits provided by the Grantor as a result of state or federal laws, rules and regulations.

To the extent the Grantee collects or maintains protected personal information as part of carrying out the Award activities, the Grantee must maintain the confidentiality of the protected personal information in accordance with applicable law and as set forth below.

(a) Personal Information Defined. As used herein, "Personal Information" shall have the definition set forth in the Personal Information Protection Act, 815 ILCS 530/5 ("PIPA").

(b) Protection of Personal Information. The Grantee must use at least reasonable care to protect the confidentiality of Personal Information that is collected or maintained as part of the Award activities and (i) not use any Personal Information for any purpose outside the scope of the Award activities and (ii) except as otherwise authorized by the Grantor in writing, limit access to Personal Information to those of its employees, contractors, and agents who need such access for purposes consistent with the Award Activities. If Grantee provides any contractor or agent with access to Personal Information, it must require the contractor or agent to comply with the provisions of this Paragraph.

(c) Security Assurances. Grantee represents and warrants that it has established and will maintain safeguards against the loss and unauthorized access, acquisition, destruction, use, modification, or disclosure of Personal Information and shall otherwise maintain the integrity of Personal Information in its possession in accordance with any federal or state law privacy requirements, including PIPA. These safeguards must be reasonably designed to (i) ensure the security and confidentiality of the Personal Information, (ii) protect against any anticipated threats or hazards to the security or integrity of Personal Information, and (iii) protect against unauthorized access to or use of Personal Information. Additionally, Grantee will have in place policies, which provide for the secure disposal of documents and information which contain Personal Information, including but not limited to shredding documents and establishing internal controls over the authorized access to such information. 815 ILCS 530/40.

(d) Breach Response. In the event of any unauthorized access to, unauthorized disclosure of, loss of, damage to or inability to account for any Personal Information (a "Breach"), Grantee agrees that it will promptly, at its own expense: (i) report such Breach to the Grantor by telephone with immediate written confirmation sent by e-mail, describing in detail any accessed materials and identifying any individual(s) who may have been involved in such Breach; (ii) take all actions necessary or reasonably requested by the Grantor to stop, limit or minimize the Breach; (iii) restore and/or retrieve, as applicable, and return all Personal Information that was lost, damaged, accessed, copied or removed; (iv) cooperate in all reasonable respects to minimize the damage resulting from such Breach; (v) provide any notice to Illinois residents as required by 815 ILCS 530/10, 815 ILCS 530/12 or applicable federal law, in consultation with the Grantor; and (vi) cooperate in the preparation of any report related to the Breach that the Grantor may need to present to any governmental body.

(e) Injunctive Relief. Grantee acknowledges that, in the event of a breach of this Paragraph, Grantor will likely suffer irreparable damage that cannot be fully remedied by monetary damages. Accordingly, in addition to any remedy which the Grantor may possess pursuant to applicable law, the Grantor retains the right to seek and obtain injunctive relief against any such breach in any Illinois court of competent jurisdiction.

(f) Compelled Access or Disclosure. The Grantee may disclose Personal Information if it is compelled by law, regulation, or legal process to do so, provided the Grantee gives the Grantor at least ten (10) days' prior notice of such compelled access or disclosure (to the extent legally permitted) and reasonable assistance if the Grantor wishes to contest the access or disclosure.

**ARTICLE XXXIV  
ADDITIONAL MISCELLANEOUS PROVISIONS**

34.1. Workers' Compensation Insurance, Social Security, Retirement and Health Insurance Benefits, and Taxes. The Grantee must provide Workers' Compensation insurance where the same is required and accepts full responsibility for the payment of unemployment insurance, premiums for Workers' Compensation, Social Security and retirement and health insurance benefits, as well as all income tax deduction and any other taxes or payroll deductions required by law for its employees who are performing services specified by this Agreement.

34.2. Required Notice. Grantee agrees to give prompt notice to the Grantor of any event that may materially affect the performance required under this Agreement. Any notice or final decision by Grantor relating to (a) a Termination or Suspension (ARTICLE XIII), (b) Modifications, Management Waivers or Term Extensions (ARTICLE XXX) or (c) Assignments (Paragraph 22.2) must be executed by the Director of the Grantor or her or his authorized designee.

**ARTICLE XXXV  
ADDITIONAL REQUIRED CERTIFICATIONS**

The Grantee makes the following certifications as a condition of this Agreement. These certifications are required by State statute and are in addition to any certifications required by any federal funding source as set forth in this Agreement. Grantee's execution of this Agreement shall serve as its attestation that the certifications made herein are true and correct.

35.1. Sexual Harassment. The Grantee certifies that it has written sexual harassment policies that must include, at a minimum, the following information: (i) the illegality of sexual harassment; (ii) the definition of sexual harassment under State law; (iii) a description of sexual harassment, utilizing examples; (iv) the Grantee's internal complaint process including penalties; (v) the legal recourse, investigative and complaint process available through the Department of Human Rights and the Human Rights Commission; (vi) directions on how to contact the Department of Human Rights and the Human Rights Commission; and (vii) protection against retaliation as provided by Sections 6-101 and 6-101.5 of the Illinois Human Rights Act. 775 ILCS 5/2-105(A)(4). A copy of the policies must be provided to the Grantor upon request.

35.2. Federal, State and Local Laws; Tax Liabilities; State Agency Delinquencies. The Grantee is required to comply with all federal, state and local laws, including but not limited to the filing of any and all applicable tax returns. If Grantee is delinquent in filing and/or paying any federal, state and/or local taxes, the Grantor will disburse Grant Funds only if the Grantee enters into an installment payment agreement with the applicable tax authority and remains in good standing with that authority. Grantee is required to tender a copy of all relevant installment payment agreements to the Grantor. In no event may Grantee utilize Grant Funds to discharge outstanding tax liabilities or other debts owed to any governmental unit. **The execution of this Agreement by the Grantee is its certification that: (i) it is current as to the filing and payment of any federal, state and/or local taxes applicable to Grantee; and (ii) it is not delinquent in its payment of moneys owed to any federal, state, or local unit of government.**

35.3. Lien Waivers. If applicable, the Grantee must monitor construction to assure that necessary contractors' affidavits and waivers of mechanics liens are obtained prior to release of Grant Funds to contractors and subcontractors.

35.4. Grant for the Construction of Fixed Works. Grantee certifies that all Projects for the construction of fixed works which are financed in whole or in part with funds provided by this Agreement will be subject to the Prevailing Wage Act (820 ILCS 130/0.01 *et seq.*) unless the provisions of that Act exempt its application. In the

construction of the Projects, Grantee must comply with the requirements of the Prevailing Wage Act including, but not limited to: (a) paying the prevailing rate of wages required by the Illinois Department of Labor, or a court on review, to all laborers, workers and mechanics performing work with Grant Funds provided through this Agreement, (b) inserting into all contracts for such construction a stipulation to the effect that not less than the prevailing rate of wages as applicable to the Project must be paid to all laborers, workers, and mechanics performing work under this Award; and (c) requiring all bonds of contractors to include a provision as will guarantee the faithful performance of the prevailing wage clause as provided by contract.

**THE REMAINDER OF THIS PAGE IS INTENTIONALLY LEFT BLANK.**

**PART THREE – PROJECT-SPECIFIC TERMS**

In addition to the uniform requirements in **PART ONE** and Grantor-Specific Terms in **PART TWO**, Grantor has the following additional requirements for this Project:

**ARTICLE XXXVI  
REPORT DELIVERABLE SCHEDULE**

36.1. External Audit Reports. External Audit Reports may be required. Refer to ARTICLE XII of this Agreement to determine whether you are required to submit an External Audit Report and the applicable due date.

36.2. Annual Financial Reports. Annual Financial Reports may be required. Refer to Paragraph 12.2 of this Agreement to determine whether you are required to submit Annual Financial Reports.

36.3. Required Periodic Reports. Below is the required periodic reporting schedule for this Award.

**July 2026**

- Quarterly Periodic Financial Report (07/30/2026) - Covering Period of 04/01/2026 - 06/30/2026; Send To: Grant Manager
- Quarterly Periodic Performance Report (07/30/2026) - Covering Period of 04/01/2026 - 06/30/2026; Send To: Grant Manager

**October 2026**

- Quarterly Periodic Financial Report (10/30/2026) - Covering Period of 07/01/2026 - 09/30/2026; Send To: Grant Manager
- Quarterly Periodic Performance Report (10/30/2026) - Covering Period of 07/01/2026 - 09/30/2026; Send To: Grant Manager

**February 2027**

- Quarterly Periodic Financial Report (02/01/2027) - Covering Period of 10/01/2026 - 12/31/2026; Send To: Grant Manager
- Quarterly Periodic Performance Report (02/01/2027) - Covering Period of 10/01/2026 - 12/31/2026; Send To: Grant Manager

**April 2027**

- Quarterly Periodic Financial Report (04/30/2027) - Covering Period of 01/01/2027 - 03/31/2027; Send To: Grant Manager
- Quarterly Periodic Performance Report (04/30/2027) - Covering Period of 01/01/2027 - 03/31/2027; Send To: Grant Manager

**July 2027**

- Quarterly Periodic Financial Report (07/30/2027) - Covering Period of 04/01/2027 - 06/30/2027; Send To: Grant Manager
- Quarterly Periodic Performance Report (07/30/2027) - Covering Period of 04/01/2027 - 06/30/2027; Send To: Grant Manager

**November 2027**

- Quarterly Periodic Financial Report (11/01/2027) - Covering Period of 07/01/2027 - 09/30/2027; Send To: Grant Manager
- Quarterly Periodic Performance Report (11/01/2027) - Covering Period of 07/01/2027 - 09/30/2027; Send To: Grant Manager

**January 2028**

- Quarterly Periodic Financial Report (01/31/2028) - Covering Period of 10/01/2027 - 12/31/2027; Send To: Grant Manager
- Quarterly Periodic Performance Report (01/31/2028) - Covering Period of 10/01/2027 - 12/31/2027; Send To: Grant Manager

**May 2028**

- Quarterly Periodic Financial Report (05/01/2028) - Covering Period of 01/01/2028 - 03/31/2028; Send To: Grant Manager
- Quarterly Periodic Performance Report (05/01/2028) - Covering Period of 01/01/2028 - 03/31/2028; Send To: Grant Manager
- End of grant Closeout Financial Report (05/15/2028) - Covering Period of 04/01/2026 - 03/31/2028; Send To: Grant Manager
- End of grant Closeout Performance Report (05/15/2028) - Covering Period of 04/01/2026 - 03/31/2028; Send To: Grant Manager

36.4. Changes to Reporting Schedule. Changes to the schedules for periodic reporting, the external audit reports and the annual financial reports do not require a formal modification to this Agreement pursuant to Paragraph 22.4 and ARTICLE XXX, and may be changed unilaterally by the Grantor if necessitated by a change in the project schedule or at the discretion of the Grantor. The Grantee may not modify the reporting deliverable schedules in ARTICLES X, XI, XII and XXXVI unilaterally, and must obtain prior written approval from Grantor or the Grant Accountability and Transparency Unit of the Governor’s Office of Management and Budget, if applicable, to change any reporting deadlines.

**ARTICLE XXXVII  
GRANT-SPECIFIC TERMS/CONDITIONS**

37.1. Funding. If this Award is bond-funded, all expenditures shall be in accordance with all applicable bondability guidelines.

37.2. Use of Real Property. Grantee shall use any real property acquired, constructed or improved with Grant Funds pursuant to this Agreement to provide the programs and services specified herein for at least the Award Term stated in Paragraph 2.1. Grantee shall comply with the real property use and disposition requirements set forth in 2 CFR 200.311.

37.3. Projects Requiring External Sign-offs.

**(1)** Pursuant to applicable statute(s), this Award requires sign-off by the following State agency(ies). **The status of the sign-off is indicated as of the date the Award is sent to the Grantee for execution:**

| AGENCY  | SIGN-OFF<br>RECEIVED | SIGN-OFF<br>OUTSTANDING |
|---|----------------------|-------------------------|
| _____ Illinois State Historic Preservation Office | _____                | _____                   |

|                     |  |               |               |
|---------------------|--|---------------|---------------|
| <u>      </u>       | Illinois Dept. of Agriculture            | <u>      </u> | <u>      </u> |
| <u>      </u>       | Illinois Dept. of Natural Resources      | <u>      </u> | <u>      </u> |
| <u>      </u>       | Illinois Environmental Protection Agency | <u>      </u> | <u>      </u> |
| <u>  <b>X</b>  </u> | NONE APPLICABLE                          |               |               |

While **any** external sign-off is outstanding, the provisions of Item (3), immediately below apply with respect to the disbursement of funds under this Award.

**NOTE: The fact that a sign-off has been received in no way relieves the Grantee of its obligation to comply with any conditions or requirements conveyed by the applicable agency(ies) in conjunction with the issuance of the sign-off for the project funded under this Agreement.**

(2) For projects subject to review by the Illinois Environmental Protection Agency (IEPA), the Grantee must, prior to construction, obtain a construction permit or “authorization to construct” from the IEPA pursuant to the provisions of the Environmental Protection Act, 415 ILCS 5/1 *et seq.*

**(3) External Sign-Off Provisions:**

- a.) The Project described in Exhibit A and funded under this Agreement is subject to review by the external agency(ies) indicated in Item (1) immediately above. Grantee must comply with requirements established by said agency(ies) relative to their respective reviews. **Any requirements communicated to the Grantor shall be incorporated into this Agreement as follows: as an attachment to this Agreement (immediately following PART THREE) at the time of the Agreement execution.** The Grantee is contractually obligated to comply with such requirements.
- b.) Grantee is responsible for coordinating directly with the applicable external agency(ies) relative to said reviews. Except as specifically provided below, the Grantor’s obligation to disburse funds under this Agreement is contingent upon notification by the applicable agency(ies) that all requirements applicable to the project described in this Agreement have been satisfied. Upon receipt of said notification, disbursement of the Grant Funds shall be authorized in accordance with the provisions of Paragraph 2.3 herein.
- c.) Prior to notification of compliance by the applicable external agency(ies), the Grantee may request disbursement of funds **only** for the following purposes: administrative, contractual, legal, engineering, or architectural costs incurred which are necessary to allow for compliance by the Grantee of requirements established by the external agency(ies). **FUNDS WILL NOT BE DISBURSED FOR LAND ACQUISITION OR ANY TYPE OF CONSTRUCTION OR OTHER ACTIVITY WHICH PHYSICALLY IMPACTS THE PROJECT SITE PRIOR TO RECEIPT BY THE GRANTOR OF THE REQUIRED NOTIFICATION FROM ALL APPLICABLE AGENCIES.**
- d.) If external sign-offs are indicated in this paragraph 37.3, disbursement of Grant Funds (whether advance or scheduled) are subject to the restrictions set forth by the External Sign-Off Provisions of this paragraph 37.3. Upon receipt of all required sign-offs, the Grantor’s Accounting Division will be notified of authorization to disburse Grant Funds in accordance with the disbursement method indicated herein.

37.4. Prevailing Wage Act Compliance. The work to be performed under this Agreement is subject to the Prevailing Wage Act (820 ILCS 130/0.01 *et seq.*). Grantee shall comply with all requirements of the Prevailing Wage Act, including but not limited to: (a) inserting into all contracts for construction a stipulation to the effect that not less than the prevailing rate of wages as applicable to the project shall be paid to all laborers, workers, and mechanics performing work under the Award and requiring all bonds of contractors to include a provision as will

guarantee the faithful performance of such prevailing wage clause as provided by contract and (b) all required reporting and documentation.

37.5. Compliance with Illinois Works Jobs Program Act. Grantee must comply with requirements in the Illinois Works Jobs Program Act (30 ILCS 559/Art. 20). For Awards with an estimated total project cost of \$500,000 or more, the Grantee will be required to comply with the Illinois Works Apprenticeship Initiative (30 ILCS 559/20-20 to 20-25) and all applicable administrative rules (see 14 Ill. Admin. Code Part 680). The “estimated total project cost” is a good faith approximation of the costs of an entire project being paid for in whole or in part by appropriated capital funds to construct a public work. Grantee must submit a Budget Supplement Form (available on the Grantor’s website) to the Grantor within ninety (90) days of the execution of this Award. The goal of the Illinois Apprenticeship Initiative is that apprentices will perform either 10% of the total labor hours actually worked in each prevailing wage classification or 10% of the estimated labor hours in each prevailing wage classification, whichever is less. Of this goal, at least half of those apprenticeship hours shall be performed by graduates of the Illinois Works Pre-apprenticeship Program, the Illinois Climate Works Pre-apprenticeship Program, or the Highway Construction Careers Training Program. Grantee is permitted to seek from the Grantor a waiver or reduction of this goal in certain circumstances pursuant to 30 ILCS 559/20-20(b). The Grantee must ensure compliance for the life of the entire project, including during the term of the Award and after the Term ends, if applicable, and will be required to report on and certify its compliance.

37.6. Compliance with Business Enterprise Program. If applicable to this Grant, Grantee acknowledges that it is required to comply with the Business Enterprise Program for Minorities, Females, and Persons with Disabilities Act (“BEP”) (30 ILCS 575/0.01 *et seq.*), which establishes a goal for contracting with businesses that have been certified as owned and controlled by persons who are minority, female or who have disabilities. Grantee shall maintain compliance with the BEP Utilization Plan submitted in conjunction with the Agreement and shall comply with all reporting requirements.

37.7. Compliance with the Employment of Illinois Workers on Public Works Act: In a period of excessive unemployment rates, Grantees (1) constructing or building any public works or (2) cleaning-up and disposing on-site of hazardous waste, and that clean-up or on-site disposal is funded or financed in whole or in part with State funds or funds administered by the State, are required to employ at least 90% Illinois laborers on such project. For projects involving clean-up and on-site disposal of hazardous waste, emergency response or immediate removal activities are excluded. This requirement applies to all labor whether skilled, semi-skilled or unskilled, whether manual or non-manual. A period of excessive unemployment rates is defined as any month immediately following two consecutive calendar months during which the level of unemployment in the State of Illinois has exceeded 5% as measured by the United States Bureau of Labor Statistics in its monthly publication of employment and unemployment figures. Any public works project financed in whole or in part by federal funds administered by the State of Illinois is covered under the provisions of this requirement, to the extent permitted by any applicable federal law or regulation. (30 ILCS 570). Grantee may receive an exception from this requirement by submitting a request and supporting documents certifying that Illinois laborers are either not available or are incapable of performing the particular type of work involved. The certification must: (a) be submitted to the agency within the first quarter of the Contract Term; (b) provide sufficient support that demonstrates the exception is met; (c) be signed by an authorized signatory of the contractor; and (d) be approved by the agency.

37.8. Interest on Grant Funds for this Award. Because this Award may be subject to the Grantor’s bondability guidelines, Grantee must comply with the interest requirements contained in Paragraph 4.7 and is not permitted to retain interest earned on Grant Funds, as stated in Paragraph 26.1, unless specifically notified by Grantor that Grantee may do so.

**ARTICLE XXXVIII  
BOND FUNDED GENERAL GRANT PROVISIONS**

38.1. Bond Funded General Grant Provisions. It is the intent of the State that all or a portion of the costs of this Project will be paid or reimbursed from the proceeds of tax-exempt bonds subsequently issued by the State.

## Conflict of Interest Disclosure

Award applicants and recipients of awards from the State of Illinois (collectively referred to herein as "Grantee") must disclose in writing to the awarding State agency any actual or potential conflict of interest that could affect the State award for which the Grantee has applied or has received. See 30 ILCS 708/35; 44 Ill. Admin Code § 7000.40(b)(3); 2 CFR § 200.112. A conflict of interest exists if an organization's officers, directors, agents, employees and/or their spouses or immediate family members use their position(s) for a purpose that is, or gives the appearance of, being motivated by a desire for a personal gain, financial or nonfinancial, whether direct or indirect, for themselves or others, particularly those with whom they have a family business or other close associations. In addition, the following conflict of interest standards apply to governmental and non-governmental entities.

### Definitions:

**Governmental Entity.** If the Grantee is a governmental entity, no officer or employee of the Grantee, member of its governing body or any other public official of the locality in which the award objectives will be carried out shall participate in any decision relating to a State award which affects his/her personal interest or the interest of any corporation, partnership or association in which he/she is directly or indirectly interested, or which affects the personal interest of a spouse or immediate family member, or has any financial interest, direct or indirect, in the work to be performed under the State award.

**Non-governmental Entity.** If the Grantee is a non-governmental entity, no officer or employee of the Grantee shall participate in any decision relating to a State award which affects his/her personal interest or the interest of any corporation, partnership or association in which he/she is directly or indirectly interested, or which affects the personal interest of a spouse or immediate family member, or has any financial interest, direct or indirect, in the work to be performed under the State award.

The Grantee shall also establish safeguards, evidenced by policies, rules and/or bylaws, to prohibit employees or officers of Grantee from engaging in actions, which create or which appear to create a conflict of interest as described herein.

**The Grantee has a continuing duty to immediately notify the Department of Commerce and Economic Opportunity (the "Department") in writing of any actual or potential conflict of interest, as well as any actions that create or which appear to create a conflict of interest.**

***Are there any current potential conflict(s) of interest, or any actions that create or which appear to create a conflict of interest, related to the State award for which your organization has applied?***

No

Yes

***If there are any current potential conflict(s) of interest, or any actions that create or which appear to create a conflict of interest, related to the State award for which your organization has applied, please describe them all here:***

If the Grantee provided information above regarding a current potential conflict of interest or any actions that create or appear to create a conflict of interest, the Grantee must immediately provide documentation to the applicable Department grant manager to support that the potential conflict of interest was appropriately handled by the Grantee's organization. If at any later time, the Grantee becomes aware of any actual or potential conflict of interest, the Grantee must notify the Department's grant manager immediately, and provide the same type of supporting documentation that describes how the conflict situation was or is being resolved.

Supporting documentation should include, but is not limited to, the following: the organization's bylaws; a list of board members; board meeting minutes; procedures to safeguard against the appearance of personal gain by the organization's officers, directors, agents, and family members; procedures detailing the proper internal controls in place; timesheets documenting time spent on the award; and bid documents supporting the selection of the contractor involved in the conflict, if applicable.

By signing this document, below, as the duly authorized representative of Grantee, I hereby certify that:

- All of the statements in this Conflict of Interest Disclosure form are true, complete and accurate to the best of my knowledge. I am aware that any false, fictitious, or fraudulent statements or claims may subject me to criminal, civil or administrative penalties. (U.S. Code, Title 18, Section 1001).
- If I become aware of any situation that conflicts with any of the representations herein, or that might indicate a potential conflict of interest or create the appearance of a conflict of interest, I or another representative from my organization will immediately notify the Department's grant manager for this award.
- I have read and I understand the requirements for the Conflict of Interest Disclosure set forth herein, and I acknowledge that my organization is bound by these requirements.

City of Des Plaines

---

Grantee Organization (Company Name):

---

Signature of Authorized Representative

---

Date

City Manager

---

Printed Title (Authorized Signator Title):

Dorothy Wisniewski

1758

---

Printed Name (Authorized Signator Name):

---

CSFA Number

Scope of Work

**SD250310**

City of Des Plaines

**EXHIBIT A: PROJECT DESCRIPTION**

The Grantee is a governmental entity which provides essential public services to the citizens of the City of Des Plaines in Cook County.

Grant funds will be utilized for a portion of the costs, including any that are prior incurred, associated with roadway improvements along the Grantee owned streets of Birch Street (Touhy to the dead end, north), Prairie Avenue (5<sup>th</sup> Street to 2<sup>nd</sup> Street), and Halsey Drive (Scott Street to Craig Drive) in the City of Des Plaines. Currently, the roadways have severe drainage issues and are in poor condition. Grant funds will cover the replacement of the roadway surface and associated curbs, gutters, sidewalks, and driveways. The project will increase the health of the Grantee's infrastructure, reduce future maintenance costs, and provide better safety and accessibility. All other costs associated with the completion of the project will be paid via the use of other funding sources.

Specifically, Grant funds will include a portion of the "Paving/Concrete/Masonry" costs associated with the removal, purchase, and installation of curbs and gutters, sidewalks, driveways, pavement, aggregate base, and asphalt binder, and surface course mix.

The completion of this project will benefit approximately 250 residents along the areas to be improved, but it will benefit thousands of residents and businesses by providing safe and reliable utilizes, drainage and roadways.



**PUBLIC WORKS AND  
ENGINEERING DEPARTMENT**

1420 Miner Street  
Des Plaines, IL 60016  
P: 847.391.5390  
desplainesil.gov

**MEMORANDUM**

Date: April 23, 2026  
 To: Dorothy Wisniewski, City Manager  
 From: Becka Shipp, P.E., Assistant Director of Engineering *ts*  
 Cc: Timothy Watkins, Director of Public Works and Engineering  
 Subject: Bid Award - 2026 CIP Water Main Improvements, Contract A

**Issue:** Bids for the 2026 CIP Water Main Improvements were opened on April 13, 2026.

**Analysis:** The project scope includes installation of new water main and service connections, abandonment or removal of old water main pipe, repair, and replacement of storm catch basins, replacement and/or lining of various existing storm and sanitary sewers, street rehabilitation or reconstruction, curb and gutter replacement, driveway apron replacement, miscellaneous sidewalk repairs, regrading of parkways, and miscellaneous landscaping restoration. The project will take place at the following locations:

| STREET         | LIMITS                            |
|----------------|-----------------------------------|
| Birch Street   | Touhy Avenue to North End         |
| Fifth Avenue   | Prospect Avenue to Algonquin Road |
| Prairie Avenue | Fifth Avenue to Second Avenue     |

The following are the bid results:

| BIDDER                           | BID AMOUNT      |
|----------------------------------|-----------------|
| John Neri Construction, Inc.     | \$6,028,939.20  |
| DiMeo Brothers, Inc              | \$6,217,855.00  |
| Martam Construction, Inc         | \$6,993,626.40  |
| Berger Contractors, Inc          | \$7,337,372.40  |
| Swallow Construction Corporation | \$8,190,696.25  |
| A Lamp Concrete Contractors, Inc | \$8,228,980.71  |
| Everlast Blacktop                | \$12,264,306.80 |

The Engineer’s Estimate was \$6,655,757.10.

After evaluation, we have deemed the low bid proposal from John Neri Construction Company, Inc. is reasonable and acceptable. The contractor has been awarded this type of contract in the past with good results and references supplied by them are favorable.

**Recommendation:** We recommend the award of the 2026 Water Main Improvements Project Contract A to John Neri Construction Company, Inc., 770 Factory Road. Addison, IL 60101 in the amount of \$6,028,939.20. The source of funding is budgeted Water Fund and Capital Projects Fund.

**Attachments:**

Resolution R-123-26

Exhibit A - Contract

**CITY OF DES PLAINES**

**RESOLUTION R - 123 - 26**

**A RESOLUTION APPROVING AN AGREEMENT WITH JOHN NERI CONSTRUCTION, INC. FOR THE 2026 CIP WATER MAIN IMPROVEMENTS.**

**WHEREAS**, Article VII, Section 10 of the 1970 Illinois Constitution authorizes the City to contract with individuals, associations, and corporations in any manner not prohibited by law or ordinance; and

**WHEREAS**, the City has appropriated funds in the Capital Projects Fund & Water and Sewers Fund for use by the Department of Public Works and Engineering during the 2026 fiscal year for the 2026 Capital Improvement Program Water Main Improvements (collectively, the "*Work*"); and

**WHEREAS**, pursuant to Chapter 10 of Title 1 of the City of Des Plaines City Code, the City issued an invitation for bids for the performance of the Work; and

**WHEREAS**, the City received seven bids, which were opened on April 13, 2026; and

**WHEREAS**, John Neri Construction, Inc. ("*Contractor*") submitted the lowest responsible bid in the amount of \$6,028,939.20; and

**WHEREAS**, the City desires to enter into an agreement with Contractor for the performance of the Work in the not-to-exceed amount of \$6,028,939.20 ("*Agreement*"); and

**WHEREAS**, the City Council has determined that it is in the best interest of the City to enter into the Agreement with Contractor;

**NOW, THEREFORE, BE IT RESOLVED** by the City Council of the City of Des Plaines, Cook County, Illinois, in the exercise of its home rule powers, as follows:

**SECTION 1: RECITALS.** The foregoing recitals are incorporated into, and made a part of, this Resolution as findings of the City Council.

**SECTION 2: APPROVAL OF AGREEMENT.** The City Council hereby approves the Agreement in substantially the form attached to this Resolution as **Exhibit A**, and in a final form to be approved by the General Counsel.

**SECTION 3: AUTHORIZATION TO EXECUTE AGREEMENT.** The City Council hereby authorizes and directs the Mayor and the City Clerk to execute and seal, on behalf of the City, the final Agreement only after receipt by the City Clerk of at least one executed copy of the Agreement from Contractor; provided, however, that if the City Clerk does not receive one executed copy of the Agreement from Contractor within 60 days after the date of adoption of this

Resolution, then this authority to execute and seal the Agreement will, at the option of the City Council, be null and void.

**SECTION 4: EFFECTIVE DATE.** This Resolution shall be in full force and effect from and after its passage and approval according to law.

**PASSED** this \_\_\_\_ day of \_\_\_\_\_, 2026.

**APPROVED** this \_\_\_\_ day of \_\_\_\_\_, 2026.

**VOTE:** AYES \_\_\_\_ NAYS \_\_\_\_ ABSENT \_\_\_\_

\_\_\_\_\_  
**MAYOR**

Approved as to form:

ATTEST:

\_\_\_\_\_  
**CITY CLERK**

\_\_\_\_\_  
**Peter M. Friedman, General Counsel**

**CITY OF DES PLAINES**



**CONTRACT FOR THE CONSTRUCTION OF  
2026 CIP WATER MAIN IMPROVEMENTS - CONTRACT A**

Prepared By

CITY OF DES PLAINES  
PUBLIC WORKS AND ENGINEERING DEPARTMENT  
1420 MINER STREET/NORTHWEST HIGHWAY  
DES PLAINES, ILLINOIS 60016

**CITY OF DES PLAINES  
 CONTRACT FOR THE CONSTRUCTION OF  
 2026 CIP WATER MAIN IMPROVEMENTS - CONTRACT A**

**TABLE OF CONTENTS**

|                    |   | <u>Page</u> |
|--------------------|---|-------------|
| <b>ARTICLE I</b>   | <b>The Work</b> .....   | 1           |
|                    | 1.1 Performance of the Work .....                                     | 1           |
|                    | 1.2 Commencement and Completion Dates .....                           | 2           |
|                    | 1.3 Required Submittals .....   | 2           |
|                    | 1.4 Review and Interpretation of Contract Provisions .....            | 3           |
|                    | 1.5 Conditions at the Work Site; Record Drawings .....                | 3           |
|                    | 1.6 Technical Ability to Perform.....                                 | 4           |
|                    | 1.7 Financial Ability to Perform.....                                 | 4           |
|                    | 1.8 Time.....   | 4           |
|                    | 1.9 Safety at the Work Site.....                                      | 5           |
|                    | 1.10 Cleanliness of the Work Site and Environs .....                  | 5           |
|                    | 1.11 Damage to the Work, the Work Site, and Other Property .....      | 5           |
|                    | 1.12 Subcontractors and Suppliers .....                               | 6           |
|                    | 1.13 Simultaneous Work By Others.....                                 | 6           |
|                    | 1.14 Occupancy Prior to Final Payment.....                            | 6           |
|                    | 1.15 Owner’s Right to Terminate or Suspend Work for Convenience ..... | 6           |
| <b>ARTICLE II</b>  | <b>Changes and Delays</b> .....                                       | 7           |
|                    | 2.1 Changes .....   | 7           |
|                    | 2.2 Delays.....   | 7           |
| <b>ARTICLE III</b> | <b>Contractor’s Responsibility for Defective Work</b> .....           | 8           |
|                    | 3.1 Inspection; Testing; Correction of Defects.....                   | 8           |
|                    | 3.2 Warranty of Work.....   | 8           |
|                    | 3.3 Owner’s Right to Correct .....                                    | 9           |
| <b>ARTICLE IV</b>  | <b>Financial Assurances</b> .....                                     | 9           |
|                    | 4.1 Bonds.....  | 9           |
|                    | 4.2 Insurance.....  | 9           |
|                    | 4.3 Indemnification.....  | 10          |
| <b>ARTICLE V</b>   | <b>Payment</b> .....  | 10          |
|                    | 5.1 Contract Price .....  | 10          |
|                    | 5.2 Taxes and Benefits .....  | 10          |

|                    |   |           |
|--------------------|---|-----------|
| 5.3                | Progress Payments .....                                   | 10        |
| 5.4                | Final Acceptance and Final Payment .....                  | 11        |
| 5.5                | Liens .....   | 11        |
| 5.6                | Deductions .....  | 12        |
| <b>ARTICLE VI</b>  | <b>Disputes And Remedies.....</b>                         | <b>13</b> |
| 6.1                | Dispute Resolution Procedure .....                        | 13        |
| 6.2                | Contractor’s Remedies .....                               | 13        |
| 6.3                | Owner’s Remedies.....                                     | 13        |
| 6.4                | Owner’s Special Remedy for Delay .....                    | 15        |
| 6.5                | Terminations and Suspensions Deemed for Convenience ..... | 15        |
| <b>ARTICLE VII</b> | <b>Legal Relationships And Requirements .....</b>         | <b>15</b> |
| 7.1                | Binding Effect .....                                      | 15        |
| 7.2                | Relationship of the Parties.....                          | 15        |
| 7.3                | No Collusion/Prohibited Interests .....                   | 15        |
| 7.4                | Assignment .....  | 16        |
| 7.5                | Confidential Information .....                            | 16        |
| 7.6                | No Waiver .....   | 16        |
| 7.7                | No Third Party Beneficiaries.....                         | 17        |
| 7.8                | Notices .....   | 17        |
| 7.9                | Governing Laws .....                                      | 17        |
| 7.10               | Changes in Laws.....                                      | 18        |
| 7.11               | Compliance with Laws .....                                | 18        |
| 7.12               | Compliance with Patents .....                             | 19        |
| 7.13               | Time.....   | 19        |
| 7.14               | Severability.....   | 19        |
| 7.15               | Entire Agreement.....                                     | 20        |
| 7.16               | Amendments.....   | 20        |

**Contractor’s Certification**

- Attachment 1:** Schedule of Prices
- Attachment 2:** Supplemental Schedule of Contract Terms
- Attachment 3:** Specifications
- Attachment 4:** List of Drawings
- Attachment 5:** Special Project Requirements
- Attachment 6:** Grant and DBE Requirements

**CITY OF DES PLAINES**  
**CONTRACT FOR THE CONSTRUCTION OF**  
**2026 CIP WATER MAIN IMPROVEMENTS - CONTRACT A**

In consideration of the mutual promises set forth below, the City of Des Plaines, 1420 Miner Street / Northwest Highway, Des Plaines, Illinois 60016, an Illinois municipal corporation (“*Owner*”), and ***John Neri Construction Company, Inc*** a ***Corporation*** (“*Contractor*”), make this Contract as of [Click here to enter a date.](#), and hereby agree as follows:

**ARTICLE I: THE WORK**

**1.1 Performance of the Work**

Contractor, at its sole cost and expense, must provide, perform, and complete all of the following, all of which is herein referred to as the “*Work*”:

1. Labor, Equipment, Materials, and Supplies. Provide, perform, and complete, in the manner described and specified in this Contract, all necessary work, labor, services, transportation, equipment, materials, apparatus, machinery, tools, fuels, gas, electric, water, waste disposal, information, data, and other means and items necessary to accomplish the Project at the Work Site, both as defined in Attachment 2, in accordance with the specifications attached hereto as Attachment 3, the drawings identified in the list attached hereto as Attachment 4, and the Special Project Requirements attached hereto as Attachment 5.
2. Permits. Except as otherwise provided in Attachment 2, procure and furnish all permits, licenses, and other governmental approvals and authorizations necessary in connection therewith.
3. Bonds and Insurance. Procure and furnish all Bonds and all certificates and policies of insurance specified in this Contract.
4. Taxes. Pay all applicable federal, state, and local taxes.
5. Miscellaneous. Do all other things required of Contractor by this Contract, including without limitation arranging for utility and other services needed for the Work and for testing, including the installation of temporary utility lines, wiring, switches, fixtures, hoses, connections, and meters, and providing sufficient sanitary conveniences and shelters to accommodate all workers and all personnel of Owner engaged in the Work.
6. Quality. Provide, perform, and complete all of the foregoing in a proper and workmanlike manner, consistent with the highest standards of professional and construction practices and in full compliance with, and as required by or pursuant to, this Contract, and with the greatest economy, efficiency, and

expedition consistent therewith, with only new, undamaged and first quality equipment, materials, and supplies.

## 1.2 Commencement and Completion Dates

Contractor must commence the Work not later than the “*Commencement Date*” set forth on Attachment 2 and must diligently and continuously prosecute the Work at such a rate as will allow the Work to be fully provided, performed, and completed in full compliance with this Contract not later than the “*Completion Date*” set forth in Attachment 2. The time of commencement, rate of progress, and time of completion are referred to in this Contract as the “*Contract Time*.”

## 1.3 Required Submittals

A. Submittals Required. Contractor must submit to Owner all documents, data, and information specifically required to be submitted by Contractor under this Contract and must, in addition, submit to Owner all such drawings, specifications, descriptive information, and engineering documents, data, and information as may be required, or as may be requested by Owner, to show the details of the Work, including a complete description of all equipment, materials, and supplies to be provided under this Contract (“*Required Submittals*”). Such details must include, but are not limited to, design data, structural and operating features, principal dimensions, space required or provided, clearances required or provided, type and brand of finish, and all similar matters, for all components of the Work.

B. Number and Format. Contractor must provide three complete sets for each Required Submittal. All Required Submittals, except drawings, must be prepared on white 8-1/2” x 11”. Two blueline prints and one sepia transparency of each drawing must be provided. All drawings must be clearly marked in the lower right-hand corner with the names of Owner and Contractor.

C. Time of Submission and Owner’s Review. All Required Submittals must be provided to Owner no later than the time, if any, specified in this Contract for their submission or, if no time for submission is specified, in sufficient time, in Owner’s sole opinion, to permit Owner to review the same prior to the commencement of the part of the Work to which they relate and prior to the purchase of any equipment, materials, or supplies that they describe. Owner will have the right to require such corrections as may be necessary to make such submittals conform to this Contract. All such submittals will, after final processing and review with no exception noted by Owner, become a part of this Contract. No Work related to any submittal may be performed by Contractor until Owner has completed review of such submittal with no exception noted. Owner’s review and stamping of any Required Submittal will be for the sole purpose of examining the general management, design, and details of the proposed Work, does not relieve Contractor of the entire responsibility for the performance of the Work in full compliance with, and as required by or pursuant to this Contract, and may not be regarded as any assumption of risk or liability by Owner.

D. Responsibility for Delay. Contractor is responsible for any delay in the Work due to delay in providing Required Submittals conforming to this Contract.

#### **1.4 Review and Interpretation of Contract Provisions**

Contractor represents and warrants that it has carefully reviewed this Contract, including all of its Attachments, and the drawings identified in Attachment 4, all of which are by this reference incorporated into and made a part of this Contract. Contractor must, at no increase in the Contract Price, provide workmanship, equipment, materials, and supplies that fully conform to this Contract. Whenever any equipment, materials or supplies are specified or described in this Contract by using the name or other identifying feature of a proprietary product or the name or other identifying feature of a particular manufacturer or vendor, the specific item mentioned is understood as establishing the type, function and quality desired. Other manufacturers' or vendors' products may be accepted, provided that the products proposed are equivalent in substance and function to those named as determined by Owner in its sole and absolute discretion.

Contractor must promptly notify Owner of any discrepancy, error, omission, ambiguity, or conflict among any of the provisions of this Contract before proceeding with any Work affected thereby. If Contractor fails to give such notice to Owner, then the subsequent decision of Owner as to which provision of this Contract governs is final, and any corrective work required does not entitle Contractor to any damages, to any compensation in excess of the Contract Price, or to any delay or extension of the Contract Time.

When the equipment, materials, or supplies furnished by Contractor cannot be installed as specified in this Contract, Contractor must, without any increase in the Contract Price, make all modifications required to properly install the equipment, materials, or supplies. Any such modification is subject to the prior review and consent of Owner.

#### **1.5 Conditions at the Work Site; Record Drawings**

Contractor represents and warrants that it has had a sufficient opportunity to conduct a thorough investigation of the Work Site and the surrounding area and has completed such investigation to its satisfaction. Contractor will have no claim for damages, for compensation in excess of the Contract Price, or for a delay or extension of the Contract Time based upon conditions found at, or in the vicinity of, the Work Site. When information pertaining to subsurface, underground or other concealed conditions, soils analysis, borings, test pits, utility locations or conditions, buried structures, condition of existing structures, and other investigations is or has been provided by Owner, or is or has been otherwise made available to Contractor by Owner, such information is or has been provided or made available solely for the convenience of Contractor and is not part of this Contract. Owner assumes no responsibility whatever in respect to the sufficiency or accuracy of such information, and there is no guaranty or warranty, either expressed or implied, that the conditions indicated are representative of those existing throughout the Work or the Work Site, or that the conditions indicated are representative of those existing at any particular location, or that the conditions indicated may not change, or that unanticipated conditions may not be present.

Contractor is solely responsible for locating all existing underground installations by prospecting no later than two workdays prior to any scheduled excavation or trenching, whichever is earlier. Contractor must check all dimensions, elevations, and quantities indicated in this Contract within the same time period as set forth above for prospecting underground installations. Contractor must lay out the Work in accordance with this Contract and must establish and maintain such locations, lines and levels. Wherever pre-existing work is encountered, Contractor must verify and be responsible for dimensions and location of such pre-existing work. Contractor must notify Owner of any discrepancy between the dimensions, elevations and quantities indicated in this Contract and the conditions of the Work Site or any other errors, omissions or discrepancies which Contractor may discover during such inspections. Full instructions will be furnished by Owner should such error, omission, or discrepancy be discovered, and Contractor must carry out such instructions as if originally specified and without any increase in Contract Price.

Before Final Acceptance of the Work, Contractor must submit to Owner two sets of Drawings of Record, unless a greater number is specified elsewhere in this Contract, indicating all field deviations from Attachment 2 or the drawings identified in Attachment 4.

#### **1.6 Technical Ability to Perform**

Contractor represents and warrants that it is sufficiently experienced and competent, and has the necessary capital, facilities, plant, organization, and staff, to provide, perform and complete the Work in full compliance with, and as required by or pursuant to, this Contract.

#### **1.7 Financial Ability to Perform**

Contractor represents and warrants that it is financially solvent, and Contractor has the financial resources necessary to provide, perform and complete the Work in full compliance with, and as required by or pursuant to, this Contract.

#### **1.8 Time**

Contractor represents and warrants that it is ready, willing, able and prepared to begin the Work on the Commencement Date and that the Contract Time is sufficient time to permit completion of the Work in full compliance with, and as required by or pursuant to, this Contract for the Contract Price, all with due regard to all natural and man-made conditions that may affect the Work or the Work Site and all difficulties, hindrances, and delays that may be incident to the Work.

#### **1.9 Safety at the Work Site**

Contractor is solely and completely responsible for providing and maintaining safe conditions at the Work Site, including the safety of all persons and property during performance of the Work. This requirement applies continuously and is not limited to normal working hours.

Contractor must take all safety precautions as necessary to comply with all applicable laws and to prevent injury to persons and damage to property.

Contractor must conduct all of its operations without interruption or interference with vehicular and pedestrian traffic on public and private rights-of-way, unless it has obtained permits therefor from the proper authorities. If any public or private right-of-way are rendered unsafe by Contractor's operations, Contractor must make such repairs or provide such temporary ways or guards as are acceptable to the proper authorities.

#### **1.10 Cleanliness of the Work Site and Environs**

Contractor must keep the Work Site and adjacent areas clean at all times during performance of the Work and must, upon completion of the Work, leave the Work Site and adjacent areas in a clean and orderly condition.

#### **1.11 Damage to the Work, the Work Site, and Other Property**

The Work and everything pertaining thereto is provided, performed, completed, and maintained at the sole risk and cost of Contractor from the Commencement Date until Final Payment. Contractor is fully responsible for the protection of all public and private property and all persons. Without limiting the foregoing, Contractor must, at its own cost and expense, provide all permanent and temporary shoring, anchoring and bracing required by the nature of the Work in order to make all parts absolutely stable and rigid, even when such shoring, anchoring and bracing is not explicitly specified, and support and protect all buildings, bridges, roadways, conduits, wires, water pipes, gas pipes, sewers, pavements, curbs, sidewalks, fixtures and landscaping of all kinds and all other public or private property that may be encountered or endangered in providing, performing and completing the Work. Contractor will have no claim against Owner because of any damage or loss to the Work or to Contractor's equipment, materials, or supplies from any cause whatsoever, including damage or loss due to simultaneous work by others. Contractor must, promptly and without charge to Owner, repair or replace, to the satisfaction of Owner, any damage done to, and any loss suffered by, the Work and any damage done to, and any loss suffered by, the Work Site or other property as a result of the Work. Notwithstanding any other provision of this Contract, Contractor's obligations under this Section exist without regard to, and may not be construed to be waived by, the availability or unavailability of any insurance, either of Owner or Contractor, to indemnify, hold harmless, or reimburse Contractor for the cost of any repair or replacement work required by this Section.

#### **1.12 Subcontractors and Suppliers**

A. Approval and Use of Subcontractors and Suppliers. Contractor must perform the Work with its own personnel and under the management, supervision, and control of its own organization unless otherwise approved by Owner in writing. All subcontractors, suppliers, and subcontracts used by Contractor must be acceptable to, and approved in advance by, Owner. Owner's approval of any subcontractor, supplier, and subcontract does not relieve Contractor of full responsibility and liability for the provision, performance, and completion of the Work in full compliance with, and as required by or pursuant to, this Contract. All Work

performed under any subcontract is subject to all of the provisions of this Contract in the same manner as if performed by employees of Contractor. Every reference in this Contract to “Contractor” is deemed also to refer to all subcontractors and suppliers of Contractor. Every subcontract must include a provision binding the subcontractor or supplier to all provisions of this Contract.

B. Removal of Subcontractors and Suppliers. If any subcontractor or supplier fails to perform the part of the Work undertaken by it in a manner satisfactory to Owner, Contractor must immediately upon notice from Owner terminate such subcontractor or supplier. Contractor will have no claim for damages, for compensation in excess of the Contract Price, or for a delay or extension of the Contract Time as a result of any such termination.

### **1.13 Simultaneous Work By Others**

Owner has the right to perform or have performed such other work as Owner may desire in, about, or near the Work Site during the performance of the Work by Contractor. Contractor must make every reasonable effort to perform the Work in such manner as to enable both the Work and such other work to be completed without hindrance or interference from each other. Contractor must afford Owner and other contractors reasonable opportunity for the execution of such other work and must properly coordinate the Work with such other work.

### **1.14 Occupancy Prior to Final Payment**

Owner will have the right, at its election, to occupy, use, or place in service any part of the Work prior to Final Payment. Such occupancy, use, or placement in service must be conducted in such manner as not to damage any of the Work or to unreasonably interfere with the progress of the Work. No such occupancy, use, or placement in service may be construed as an acceptance of any of the Work or a release or satisfaction of Contractor’s duty to insure and protect the Work, nor may it, unless conducted in an unreasonable manner, be considered as an interference with Contractor’s provision, performance, or completion of the Work.

### **1.15 Owner’s Right to Terminate or Suspend Work for Convenience**

A. Termination or Suspension for Convenience. Owner has the right, for its convenience, to terminate or suspend the Work in whole or in part at any time by written notice to Contractor. Every such notice must state the extent and effective date of such termination or suspension. On such effective date, Contractor must, as and to the extent directed, stop Work under this Contract, cease all placement of further orders or subcontracts, terminate or suspend Work under existing orders and subcontracts, cancel any outstanding orders or subcontracts that may be cancelled, and take any action necessary to protect any property in its possession in which Owner has or may acquire any interest and to dispose of such property in such manner as may be directed by Owner.

B. Payment for Completed Work. In the event of any termination pursuant to Subsection 1.15A above, Owner must pay Contractor (1) such direct costs, excluding overhead, as Contractor has paid or incurred for all Work done in compliance with, and as required by or

pursuant to, this Contract up to the effective date of termination together with ten percent of such costs for overhead and profit; and (2) such other costs pertaining to the Work, exclusive of overhead and profit, as Contractor may have reasonably and necessarily incurred as the result of such termination. Any such payment may be offset by any prior payment or payments and is subject to Owner's rights to withhold and deduct as provided in this Contract.

## ARTICLE II: CHANGES AND DELAYS

### 2.1 Changes

Owner has the right, by written order executed by Owner, to make changes in the Contract, the Work, the Work Site, and the Contract Time ("*Change Order*"). If any Change Order causes an increase or decrease in the amount of the Work, an equitable adjustment in the Contract Price or Contract Time may be made. All claims by Contractor for an equitable adjustment in either the Contract Price or the Contract Time must be made within two business days following receipt of such Change Order, and may, if not made prior to such time, be conclusively deemed to have been waived. No decrease in the amount of the Work caused by any Change Order will entitle Contractor to make any claim for damages, anticipated profits, or other compensation.

### 2.2 Delays

A. Extensions for Unavoidable Delays. For any delay that may result from causes that could not be avoided or controlled by Contractor, Contractor must, upon timely written application, be entitled to issuance of a Change Order providing for an extension of the Contract Time for a period of time equal to the delay resulting from such unavoidable cause. No extension of the Contract Time will be allowed for any other delay in completion of the Work.

B. No Compensation for Delays. No payment, compensation, damages, or adjustment of any kind, other than the extension of the Contract Time provided in Subsection 2.2A above, may be made to, or claimed by, Contractor because of hindrances or delays from any cause in the commencement, prosecution, or completion of the Work, whether caused by Owner or any other party and whether avoidable or unavoidable.

## ARTICLE III: CONTRACTOR'S RESPONSIBILITY FOR DEFECTIVE WORK

### 3.1 Inspection; Testing; Correction of Defects

A. Inspection. Until Final Payment, all parts of the Work are subject to inspection and testing by Owner or its designated representatives. Contractor must furnish, at its own expense, all reasonable access, assistance, and facilities required by Owner for such inspection and testing.

B. Re-Inspection. Re-inspection and re-testing of any Work may be ordered by Owner at any time, and, if so ordered, any covered or closed Work must be uncovered or opened

by Contractor. If the Work is found to be in full compliance with this Contract, then Owner must pay the cost of uncovering, opening, re-inspecting, or re-testing, as the case may be. If such Work is not in full compliance with this Contract, then Contractor must pay such cost.

C. Correction. Until Final Payment, Contractor must, promptly and without charge, repair, correct, or replace all or any part of the Work that is defective, damaged, flawed, or unsuitable or that in any way fails to conform strictly to the requirements of this Contract.

### **3.2 Warranty of Work**

A. Scope of Warranty. Contractor warrants that the Work and all of its components will be free from defects and flaws in design, workmanship, and materials; must strictly conform to the requirements of this Contract; and will be fit, sufficient, and suitable for the purposes expressed in, or reasonably inferred from, this Contract. The warranty herein expressed is in addition to any other warranties expressed in this Contract, or expressed or implied by law, which are hereby reserved unto Owner.

B. Repairs; Extension of Warranty. Contractor, promptly and without charge, must correct any failure to fulfill the above warranty that may be discovered or develop at any time within one year after Final Payment or such longer period as may be prescribed in Attachment 2 or Attachment 5 to this Contract or by law. The above warranty may be extended automatically to cover all repaired and replacement parts and labor provided or performed under such warranty and Contractor's obligation to correct Work may be extended for a period of one year from the date of such repair or replacement. The time period established in this Subsection 3.2B relates only to the specific obligation of Contractor to correct Work and may not be construed to establish a period of limitation with respect to other obligations that Contractor has under this Contract.

C. Subcontractor and Supplier Warranties. Whenever Attachment 2 or Attachment 5 requires a subcontractor or supplier to provide a guaranty or warranty, Contractor is solely responsible for obtaining said guaranty or warranty in form satisfactory to Owner and assigning said warranty or guaranty to Owner. Acceptance of any assigned warranties or guaranties by Owner is a precondition to Final Payment and does not relieve Contractor of any of its guaranty or warranty obligations under this Contract.

### **3.3 Owner's Right to Correct**

If, within two business days after Owner gives Contractor notice of any defect, damage, flaw, unsuitability, nonconformity, or failure to meet warranty subject to correction by Contractor pursuant to Section 3.1 or Section 3.2 of this Contract, Contractor neglects to make, or undertake with due diligence to make, the necessary corrections, then Owner is entitled to make, either with its own forces or with contract forces, the corrections and to recover from Contractor all resulting costs, expenses, losses, or damages, including attorneys' fees and administrative expenses.

## ARTICLE IV: FINANCIAL ASSURANCES

### 4.1 Bonds

Contemporaneous with Contractor's execution of this Contract, Contractor must provide a Performance Bond and a Labor and Material Payment Bond, on forms provided by, or otherwise acceptable to, Owner, from a surety company licensed to do business in the State of Illinois with a general rating of A and a financial size category of Class X or better in Best's Insurance Guide, each in the penal sum of the Contract Price ("*Bonds*"). Contractor, at all times while providing, performing, or completing the Work, including, without limitation, at all times while correcting any failure to meet warranty pursuant to Section 3.2 of this Contract, must maintain and keep in force, at Contractor's expense, the Bonds required hereunder.

### 4.2 Insurance

Contemporaneous with Contractor's execution of this Contract, Contractor must provide certificates and policies of insurance evidencing the minimum insurance coverages and limits set forth in Attachment 2. For good cause shown, Owner may extend the time for submission of the required policies of insurance upon such terms, and with such assurances of complete and prompt performance, as Owner may impose in the exercise of its sole discretion. Such policies must be in a form, and from companies, acceptable to Owner. Such insurance must provide that no change, modification in, or cancellation of any insurance becomes effective until the expiration of 30 days after written notice thereof has been given by the insurance company to Owner. Contractor must, at all times while providing, performing, or completing the Work, including, without limitation, at all times while correcting any failure to meet warranty pursuant to Section 3.2 of this Contract, maintain and keep in force, at Contractor's expense, the minimum insurance coverages and limits set forth in Attachment 2.

### 4.3 Indemnification

Contractor hereby agrees to and will indemnify, save harmless, and defend Owner and all of its elected officials, officers, employees, attorneys, agents, and representatives against any and all lawsuits, claims, demands, damages, liabilities, losses, and expenses, including attorneys' fees and administrative expenses, that may arise, or be alleged to have arisen, out of or in connection with Contractor's performance of, or failure to perform, the Work or any part thereof, whether or not due or claimed to be due in whole or in part to the active, passive, or concurrent negligence or fault of Contractor, except to the extent caused solely by the negligence of Owner.

## ARTICLE V: PAYMENT

### 5.1 Contract Price

Owner must pay to Contractor, in accordance with and subject to the terms and conditions set forth in this Article V and Attachment 2, and Contractor must accept in full satisfaction for providing, performing, and completing the Work, the amount or amounts set

forth in Attachment 2 (the “*Contract Price*”), subject to any additions, deductions, or withholdings provided for in this Contract.

## **5.2 Taxes and Benefits**

Owner is exempt from and will not be responsible to pay, or reimburse Contractor for, any state or local sales, use, or excise taxes. The Contract Price includes all other applicable federal, state, and local taxes of every kind and nature applicable to the Work as well as all taxes, contributions, and premiums for unemployment insurance, old age or retirement benefits, pensions, annuities, or other similar benefits. All claim or right to claim additional compensation by reason of the payment of any such tax, contribution, or premium is hereby waived and released by Contractor.

## **5.3 Progress Payments**

A. Payment in Installments. The Contract Price must be paid in monthly installments in the manner set forth in Attachment 2 (“*Progress Payments*”).

B. Pay Requests. Contractor must, as a condition precedent to its right to receive each Progress Payment, submit to Owner a pay request in the form provided by Owner (“*Pay Request*”). The first Pay Request must be submitted not sooner than 30 days following commencement of the Work. Owner may, by written notice to Contractor, designate a specific day of each month on or before which Pay Requests must be submitted. Each Pay Request must include (a) Contractor’s certification of the value of, and partial or final waivers of lien covering, all Work for which payment is then requested and (b) Contractor’s certification that all prior Progress Payments have been properly applied to the payment or reimbursement of the costs with respect to which they were paid.

C. Work Entire. This Contract and the Work are entire and the Work as a whole is of the essence of this Contract. Notwithstanding any other provision of this Contract, each and every part of this Contract and of the Work are interdependent and common to one another and to Owner’s obligation to pay all or any part of the Contract Price or any other consideration for the Work. Any and all Progress Payments made pursuant to this Article are provided merely for the convenience of Contractor and for no other purpose.

## **5.4 Final Acceptance and Final Payment**

A. Notice of Completion. When the Work has been completed and is ready in all respects for acceptance by Owner, Contractor must notify Owner and request a final inspection (“*Notice of Completion*”). Contractor’s Notice of Completion must be given sufficiently in advance of the Completion Date to allow for scheduling of the final inspection and for completion or correction before the Completion Date of any items identified by such inspection as being defective, damaged, flawed, unsuitable, nonconforming, incomplete, or otherwise not in full compliance with, or as required by or pursuant to, this Contract (“*Punch List Work*”).

B. Punch List and Final Acceptance. The Work may be finally accepted when, and only when, the whole and all parts thereof have been completed to the satisfaction of Owner in full compliance with, and as required by or pursuant to, this Contract. Upon receipt of Contractor's Notice of Completion, Owner must make a review of the Work and notify Contractor in writing of all Punch List Work, if any, to be completed or corrected. Following Contractor's completion or correction of all Punch List Work, Owner must make another review of the Work and prepare and deliver to Contractor either a written notice of additional Punch List Work to be completed or corrected or a written notice of final acceptance of the Work ("*Final Acceptance*").

C. Final Payment. As soon as practicable after Final Acceptance, Contractor must submit to Owner a properly completed final Pay Request in the form provided by Owner ("*Final Pay Request*"). Owner must pay to Contractor the balance of the Contract Price, after deducting therefrom all charges against Contractor as provided for in this Contract ("*Final Payment*"). Final Payment must be made not later than 60 days after Owner approves the Final Pay Request. The acceptance by Contractor of Final Payment will operate as a full and complete release of Owner of and from any and all lawsuits, claims, demands, damages, liabilities, losses, and expenses of, by, or to Contractor for anything done, furnished for, arising out of, relating to, or in connection with the Work or for or on account of any act or neglect of Owner arising out of, relating to, or in connection with the Work.

## 5.5 Liens

A. Title. Nothing in this Contract may be construed as vesting in Contractor any right of property in any equipment, materials, supplies, and other items provided under this Contract after they have been installed in, incorporated into, attached to, or affixed to, the Work or the Work Site. All such equipment, materials, supplies, and other items will, upon being so installed, incorporated, attached or affixed, become the property of Owner, but such title will not release Contractor from its duty to insure and protect the Work in accordance with the requirements of this Contract.

B. Waivers of Lien. Contractor must, from time to time at Owner's request and in any event prior to Final Payment, furnish to Owner such receipts, releases, affidavits, certificates, and other evidence as may be necessary to establish, to the reasonable satisfaction of Owner, that no lien against the Work or the public funds held by Owner exists in favor of any person whatsoever for or by reason of any equipment, material, supplies, or other item furnished, labor performed, or other thing done in connection with the Work or this Contract ("*Lien*") and that no right to file any Lien exists in favor of any person whatsoever.

C. Removal of Liens. If at any time any notice of any Lien is filed, then Contractor must, promptly and without charge, discharge, remove, or otherwise dispose of such Lien. Until such discharge, removal, or disposition, Owner will have the right to retain from any money payable hereunder an amount that Owner, in its sole judgment, deems necessary to satisfy such Lien and to pay the costs and expenses, including attorneys' fees and administrative expenses, of any actions brought in connection therewith or by reason thereof.

D. Protection of Owner Only. This Section does not operate to relieve Contractor's surety or sureties from any of their obligations under the Bonds, nor may it be deemed to vest any right, interest, or entitlement in any subcontractor or supplier. Owner's retention of funds pursuant to this Section is deemed solely for the protection of its own interests pending removal of such Liens by Contractor, and Owner will have no obligation to apply such funds to such removal but may, nevertheless, do so where Owner's interests would thereby be served.

## 5.6 Deductions

A. Owner's Right to Withhold. Notwithstanding any other provision of this Contract and without prejudice to any of Owner's other rights or remedies, Owner will have the right at any time or times, whether before or after approval of any Pay Request, to deduct and withhold from any Progress or Final Payment that may be or become due under this Contract such amount as may reasonably appear necessary to compensate Owner for any actual or prospective loss due to: (1) Work that is defective, damaged, flawed, unsuitable, nonconforming, or incomplete; (2) damage for which Contractor is liable under this Contract; (3) state or local sales, use, or excise taxes from which Owner is exempt; (4) Liens or claims of Lien regardless of merit; (5) claims of subcontractors, suppliers, or other persons regardless of merit; (6) delay in the progress or completion of the Work; (7) inability of Contractor to complete the Work; (8) failure of Contractor to properly complete or document any Pay Request; (9) any other failure of Contractor to perform any of its obligations under this Contract; or (10) the cost to Owner, including attorneys' fees and administrative costs, of correcting any of the aforesaid matters or exercising any one or more of Owner's remedies set forth in Section 6.3 of this Contract.

B. Use of Withheld Funds. Owner is entitled to retain any and all amounts withheld pursuant to Subsection 5.6A above until Contractor has either performed the obligations in question or furnished security for such performance satisfactory to Owner. Owner is entitled to apply any money withheld or any other money due Contractor under this Contract to reimburse itself for any and all costs, expenses, losses, damages, liabilities, suits, judgments, awards, attorneys' fees and administrative expenses incurred, suffered, or sustained by Owner and chargeable to Contractor under this Contract.

## ARTICLE VI: DISPUTES AND REMEDIES

### 6.1 Dispute Resolution Procedure

A. Notice of Disputes and Objections. If Contractor disputes or objects to any requirement, direction, instruction, interpretation, determination, or decision of Owner, Contractor may notify Owner in writing of its dispute or objection and of the amount of any equitable adjustment to the Contract Price or Contract Time to which Contractor claims it will be entitled as a result thereof; provided, however, that Contractor must, nevertheless, proceed without delay to perform the Work as required, directed, instructed, interpreted, determined, or decided by Owner, without regard to such dispute or objection. Unless Contractor so notifies Owner within two business days after receipt of such requirement, direction, instruction,

interpretation, determination, or decision, Contractor is conclusively deemed to have waived all such disputes or objections and all claims based thereon.

B. Negotiation of Disputes and Objections. To avoid and settle without litigation any such dispute or objection, Owner and Contractor agree to engage in good faith negotiations. Within three business days after Owner's receipt of Contractor's written notice of dispute or objection, a conference between Owner and Contractor will be held to resolve the dispute. Within three business days after the end of the conference, Owner must render its final decision, in writing, to Contractor. If Contractor objects to the final decision of Owner, then it must, within three business days, give Owner notice thereof and, in such notice, must state its final demand for settlement of the dispute. Unless Contractor so notifies Owner, Contractor will be conclusively deemed (1) to have agreed to and accepted Owner's final decision and (2) to have waived all claims based on such final decision.

## **6.2 Contractor's Remedies**

If Owner fails or refuses to satisfy a final demand made by Contractor pursuant to Section 6.1 of this Contract, or to otherwise resolve the dispute which is the subject of such demand to the satisfaction of Contractor, within 10 days after receipt of such demand, then Contractor will be entitled to pursue such remedies, not inconsistent with the provisions of this Contract, as it may have in law or equity.

## **6.3 Owner's Remedies**

If it should appear at any time prior to Final Payment that Contractor has failed or refused to prosecute, or has delayed in the prosecution of, the Work with diligence at a rate that assures completion of the Work in full compliance with the requirements of this Contract on or before the Completion Date, or has attempted to assign this Contract or Contractor's rights under this Contract, either in whole or in part, or has falsely made any representation or warranty in this Contract, or has otherwise failed, refused, or delayed to perform or satisfy any other requirement of this Contract or has failed to pay its debts as they come due ("*Event of Default*"), and has failed to cure any such Event of Default within five business days after Contractor's receipt of written notice of such Event of Default, then Owner will have the right, at its election and without prejudice to any other remedies provided by law or equity, to pursue any one or more of the following remedies:

1. Owner may require Contractor, within such reasonable time as may be fixed by Owner, to complete or correct all or any part of the Work that is defective, damaged, flawed, unsuitable, nonconforming, or incomplete; to remove from the Work Site any such Work; to accelerate all or any part of the Work; and to take any or all other action necessary to bring Contractor and the Work into strict compliance with this Contract.
2. Owner may perform or have performed all Work necessary for the accomplishment of the results stated in Paragraph 1 above and withhold or

recover from Contractor all the cost and expense, including attorneys' fees and administrative costs, incurred by Owner in connection therewith.

3. Owner may accept the defective, damaged, flawed, unsuitable, nonconforming, incomplete, or dilatory Work or part thereof and make an equitable reduction in the Contract Price.
4. Owner may terminate this Contract without liability for further payment of amounts due or to become due under this Contract.
5. Owner may, without terminating this Contract, terminate Contractor's rights under this Contract and, for the purpose of completing or correcting the Work, evict Contractor and take possession of all equipment, materials, supplies, tools, appliances, plans, specifications, schedules, manuals, drawings, and other papers relating to the Work, whether at the Work Site or elsewhere, and either complete or correct the Work with its own forces or contracted forces, all at Contractor's expense.
6. Upon any termination of this Contract or of Contractor's rights under this Contract, and at Owner's option exercised in writing, any or all subcontracts and supplier contracts of Contractor will be deemed to be assigned to Owner without any further action being required, but Owner may not thereby assume any obligation for payments due under such subcontracts and supplier contracts for any Work provided or performed prior to such assignment.
7. Owner may withhold from any Progress Payment or Final Payment, whether or not previously approved, or may recover from Contractor, any and all costs, including attorneys' fees and administrative expenses, incurred by Owner as the result of any Event of Default or as a result of actions taken by Owner in response to any Event of Default.
8. Owner may recover any damages suffered by Owner.

#### **6.4 Owner's Additional Remedy for Delay**

If the Work is not completed by Contractor, in full compliance with, and as required by or pursuant to, this Contract, within the Contract Time as such time may be extended by Change Order, then Owner may invoke its remedies under Section 6.3 of this Contract or may, in the exercise of its sole and absolute discretion, permit Contractor to complete the Work but charge to Contractor, and deduct from any Progress or Final Payments, whether or not previously approved, administrative expenses and costs for each day completion of the Work is delayed beyond the Completion Date, computed on the basis of the "*Per Diem Administrative Charge*" set forth in Attachment 2, as well as any additional damages caused by such delay.

**6.5 Terminations and Suspensions Deemed for Convenience**

Any termination or suspension of Contractor's rights under this Contract for an alleged default that is ultimately held unjustified will automatically be deemed to be a termination or suspension for the convenience of Owner under Section 1.15 of this Contract.

**ARTICLE VII: LEGAL RELATIONSHIPS  
AND REQUIREMENTS****7.1 Binding Effect**

This Contract is binding on Owner and Contractor and on their respective heirs, executors, administrators, personal representatives, and permitted successors and assigns. Every reference in this Contract to a party is deemed to be a reference to the authorized officers, employees, agents, and representatives of such party.

**7.2 Relationship of the Parties**

Contractor will act as an independent contractor in providing and performing the Work. Nothing in, nor done pursuant to, this Contract may be construed (1) to create the relationship of principal and agent, partners, or joint ventures between Owner and Contractor or (2) except as provided in Paragraph 6.3(6) above, to create any relationship between Owner and any subcontractor or supplier of Contractor.

**7.3 No Collusion/Prohibited Interests**

Contractor hereby represents that the only persons, firms, or corporations interested in this Contract as principals are those disclosed to Owner prior to the execution of this Contract, and that this Contract is made without collusion with any other person, firm, or corporation. If at any time it is found that Contractor has, in procuring this Contract, colluded with any other person, firm, or corporation, then Contractor will be liable to Owner for all loss or damage that Owner may suffer thereby, and this Contract will, at Owner's option, be null and void.

Contractor hereby represents and warrants that neither Contractor nor any person affiliated with Contractor or that has an economic interest in Contractor or that has or will have an interest in the Work or will participate, in any manner whatsoever, in the Work is acting, directly or indirectly, for or on behalf of any person, group, entity or nation named by the United States Treasury Department as a Specially Designated National and Blocked Person, or for or on behalf of any person, group, entity or nation designated in Presidential Executive Order 13224 as a person who commits, threatens to commit, or supports terrorism, and neither Contractor nor any person affiliated with Contractor or that has an economic interest in Contractor or that has or will have an interest in the Work or will participate, in any manner whatsoever, in the Work is, directly or indirectly, engaged in, or facilitating, the Work on behalf of any such person, group, entity or nation.

**7.4 Assignment**

Contractor may not (1) assign this Contract in whole or in part, (2) assign any of Contractor's rights or obligations under this Contract, or (3) assign any payment due or to become due under this Contract without the prior express written approval of Owner, which approval may be withheld in the sole and unfettered discretion of Owner; provided, however, that Owner's prior written approval will not be required for assignments of accounts, as defined in the Illinois Commercial Code, if to do so would violate Section 9-318 of the Illinois Commercial Code, 810 ILCS 5/9-318. Owner may assign this Contract, in whole or in part, or any or all of its rights or obligations under this Contract, without the consent of Contractor.

**7.5 Confidential Information**

All information supplied by Owner to Contractor for or in connection with this Contract or the Work must be held confidential by Contractor and may not, without the prior express written consent of Owner, be used for any purpose other than performance of the Work.

**7.6 No Waiver**

No examination, inspection, investigation, test, measurement, review, determination, decision, certificate, or approval by Owner, nor any order by Owner for the payment of money, nor any payment for, or use, occupancy, possession, or acceptance of, the whole or any part of the Work by Owner, nor any extension of time granted by Owner, nor any delay by Owner in exercising any right under this Contract, nor any other act or omission of Owner may constitute or be deemed to be an acceptance of any defective, damaged, flawed, unsuitable, nonconforming or incomplete Work, equipment, materials, or supplies, nor operate to waive or otherwise diminish the effect of any warranty or representation made by Contractor; or of any requirement or provision of this Contract; or of any remedy, power, or right of Owner.

**7.7 No Third Party Beneficiaries**

No claim as a third party beneficiary under this Contract by any person, firm, or corporation other than Contractor may be made or be valid against Owner.

**7.8 Notices**

All notices required or permitted to be given under this Contract must be in writing and are deemed received by the addressee thereof when delivered in person on a business day at the address set forth below or on the third business day after being deposited in any main or branch United States post office, for delivery at the address set forth below by properly addressed, postage prepaid, certified or registered mail, return receipt requested.

Notices and communications to Owner must be addressed to, and delivered at, the following address:

City of Des Plaines  
 1420 Miner Street  
 Des Plaines, Illinois 60016  
 Attention: City Manager

with a copy to:  
 Elrod Friedman, LLP  
 325 North La Salle Street, Suite 450  
 Chicago, Illinois 60654  
 Attention: Peter Friedman

Notices and communications to Contractor must be addressed to, and delivered at, the following address:

**John Neri Construction Company, Inc.**  
**770 Factory Road, Addison, IL 60101**

---

The foregoing may not be deemed to preclude the use of other non-oral means of notification or to invalidate any notice properly given by any such other non-oral means.

By notice complying with the requirements of this Section, Owner and Contractor each have the right to change the address or addressee or both for all future notices to it, but no notice of a change of address is effective until actually received.

#### **7.9 Governing Laws**

This Contract and the rights of Owner and Contractor under this Contract will be interpreted according to the internal laws, but not the conflict of laws rules, of the State of Illinois.

#### **7.10 Changes in Laws**

Unless otherwise explicitly provided in this Contract, any reference to laws includes such laws as they may be amended or modified from time to time.

#### **7.11 Compliance with Laws**

A. Compliance Required. Contractor, and each subcontractor, must give all notices, pay all fees, and take all other action that may be necessary to ensure that the Work is provided, performed, and completed in accordance with all required governmental permits, licenses or other approvals and authorizations that may be required in connection with providing, performing, and completing the Work, and with all applicable statutes, ordinances, rules, and regulations, including without limitation the Illinois Prevailing Wage Act, 820 ILCS 130/0.01 et seq. (see Subsection C of this Section); any other applicable prevailing wage laws; the Fair Labor Standards Act; any statutes regarding qualification to do business; any statutes requiring preference to laborers of specified classes; the Illinois Steel Products Procurement Act, 30 ILCS 565/1 et seq.; any statutes prohibiting discrimination because of, or requiring affirmative action based on, race, creed, color, national origin, age, sex, or other prohibited classification, including, without limitation, the Americans with Disabilities Act of 1990, 42 U.S.C. §§ 12101 et seq., the Illinois Human Rights Act, 775 ILCS 5/1 101 et seq., and the

Public Works Discrimination Act, 775 ILCS 10/0.01 et seq.; the Employment of Illinois Workers on Public Works Act, 30 ILCS 570/0.01 et seq ; and any statutes regarding safety or the performance of the Work, including the Illinois Underground Utility Facilities Damage Prevention Act, 220 ILCS 50/1 et seq., and the Occupational Safety and Health Act of 1970, 29 U.S.C. §§ 651 et seq.

B. Liability for Fines, Penalties. Contractor is solely liable for any fines or civil penalties that are imposed by any governmental or quasi-governmental agency or body that may arise, or be alleged to have arisen, out of or in connection with Contractor's, or its subcontractors' or suppliers', performance of, or failure to perform, the Work or any part thereof.

C. Prevailing Wages, Certified Payroll Required. This Contract calls for the construction of a "public work," within the meaning of the Illinois Prevailing Wage Act, 820 ILCS 130/0.01 et seq. (the "Act"). Contractor and each subcontractor must pay the prevailing wage as determined by the Illinois Department for each trade or craft. If the Illinois Department of Labor revises the prevailing wages to be paid, the revised rates will apply to this Contract. Contractor and each subcontractor must comply with all of the provisions of the Act , including filing certified payrolls on a monthly basis with the Illinois Department of Labor, in accordance with Section 5 of the Act. Contract and each subcontract must furnish a copy of the payrolls to the Owner. The certified payroll must consist of a complete copy of those records required to be made and kept by the Act. The certified payroll must be accompanied by a statement signed by the contractor or subcontractor that certifies that (1) such records are true and accurate, (2) the hourly rate paid is not less than the general prevailing rate of hourly wages required by the Act, and (3) the contractor or subcontractor is aware that filing a certified payroll that they know to be false is a Class B misdemeanor. On two business days' notice, Contractor and each subcontractor must make available for inspection the records required to be made and kept by the Act (i) to the Owner and its officers and agents and to the Director of the Illinois Department of Labor and his or her deputies and agents and (ii) at all reasonable hours at a location within the State.

D. Qualified. Bidder has the requisite experience, ability, capital, facilities, plant, organization, and staff to enable Bidder to perform the Work successfully and promptly and to commence and complete the Work within the Contract Price and Contract Time set forth above. Bidder warrants and represents that it has met and will meet all required standards set forth in Owner's Responsible Bidder Ordinance set forth in Section 1-10-2.B of the City Code, including, without limitation, that Bidder and all of Bidder's subcontractors actively participate, and have actively participated for at least 12 months before the bid opening date, in an apprenticeship and training program approved and registered with the United States Department Labor Bureau of Apprenticeship and Training for each of the trades that will perform Work under this Contract.

E. Required Provisions Deemed Inserted. Every provision of law required by law to be inserted into this Contract is deemed to be inserted herein.

## 7.12 Compliance with Patents

A. Assumption of Costs, Royalties, and Fees. Contractor will pay or cause to be paid all costs, royalties, and fees arising from the use on, or the incorporation into, the Work, of patented equipment, materials, supplies, tools, appliances, devices, processes, or inventions.

B. Effect of Contractor Being Enjoined. Should Contractor be enjoined from furnishing or using any equipment, materials, supplies, tools, appliances, devices, processes, or inventions supplied or required to be supplied or used under this Contract, Contractor must promptly offer substitute equipment, materials, supplies, tools, appliances, devices, processes, or inventions in lieu thereof, of equal efficiency, quality, suitability, and market value, for review by Owner. If Owner should disapprove the offered substitutes and should elect, in lieu of a substitution, to have supplied, and to retain and use, any such equipment, materials, supplies, tools, appliances, devices, processes, or inventions as may by this Contract be required to be supplied, Contractor must pay such royalties and secure such valid licenses as may be requisite and necessary for Owner to use such equipment, materials, supplies, tools, appliances, devices, processes, or inventions without being disturbed or in any way interfered with by any proceeding in law or equity on account thereof. Should Contractor neglect or refuse to make any approved substitution promptly, or to pay such royalties and secure such licenses as may be necessary, then Owner will have the right to make such substitution, or Owner may pay such royalties and secure such licenses and charge the cost thereof against any money due Contractor from Owner or recover the amount thereof from Contractor and its surety or sureties notwithstanding that Final Payment may have been made.

### 7.13 Time

The Contract Time is of the essence of this Contract. Except where otherwise stated, references in this Contract to days is construed to refer to calendar days.

### 7.14 Severability

The provisions of this Contract will be interpreted when possible to sustain their legality and enforceability as a whole. In the event any provision of this Contract is held invalid, illegal, or unenforceable by a court of competent jurisdiction, in whole or in part, neither the validity of the remaining part of such provision, nor the validity of any other provisions of this Contract will be in any way affected thereby.

### 7.15 Entire Agreement

This Contract sets forth the entire agreement of Owner and Contractor with respect to the accomplishment of the Work and the payment of the Contract Price therefor, and there are no other understandings or agreements, oral or written, between Owner and Contractor with respect to the Work and the compensation therefor.

### 7.16 Amendments

No modification, addition, deletion, revision, alteration or other change to this Contract is effective unless and until such change is reduced to writing and executed and delivered by Owner and Contractor.

IN WITNESS WHEREOF, Owner and Contractor have caused this Contract to be executed by their properly authorized representatives in two original counterparts as of the Effective Date.

**CITY OF DES PLAINES**

By: \_\_\_\_\_

Name: \_\_\_\_\_

Title: \_\_\_\_\_

Attest:

By: \_\_\_\_\_

Name: \_\_\_\_\_

Title: \_\_\_\_\_

***John Neri Construction Company, Inc***

By: \_\_\_\_\_

Name: \_\_\_\_\_

Title: \_\_\_\_\_

Attest:

By: \_\_\_\_\_

Name: \_\_\_\_\_

Title: \_\_\_\_\_

STATE OF ILLINOIS        )  
  )  
COUNTY OF \_\_\_\_\_  )

SS

CONTRACTOR’S CERTIFICATION

I \_\_\_\_\_, being first duly sworn on oath, deposes and states that all statements herein made are made on behalf of Contractor, that this deponent is authorized to make them, and that the statements contained herein are true and correct.

Contractor deposes, states, and certifies that Contractor is not barred from contracting with a unit of state or local government as a result of (i) a violation of either Section 33E-3 or Section 33E-4 of Article 33E of the Criminal Code of 1961, 720 ILCS 5/33E-1 et seq.; or (ii) a violation of the USA Patriot Act of 2001, 107 Public Law 56 (October 26, 2001) (the “*Patriot Act*”) or other statutes, orders, rules, and regulations of the United States government and its various executive departments, agencies and offices related to the subject matter of the Patriot Act, including, but not limited to, Executive Order 13224 effective September 24, 2001.

DATED: \_\_\_\_\_, 2026\_\_.

***John Neri Construction Company, Inc***

By: \_\_\_\_\_

Name: \_\_\_\_\_

Title: \_\_\_\_\_

Attest:

By: \_\_\_\_\_

Name: \_\_\_\_\_

Title: \_\_\_\_\_

Subscribed and Sworn to before me on \_\_\_\_\_, 2026\_\_.

My Commission expires: \_\_\_\_\_

\_\_\_\_\_  
Notary Public

(SEAL)

## 2026 CIP WATER MAIN IMPROVEMENTS - CONTRACT A

### SCHEDULE OF PRICES - ADDENDUM #1

| ITEM # | PAY ITEM  | UNIT    | TOTAL QUANTITY | UNIT COST    | TOTAL COST    |
|--------|---|---------|----------------|--------------|---------------|
| 1      | EXPLORATION TRENCH  | FOOT    | 150            | \$ 1.00      | \$ 150.00     |
| 2      | INLET FILTERS   | EACH    | 50             | \$ 10.00     | \$ 500.00     |
| 3      | TREE REMOVAL (OVER 15 INCH-DIAMETER)                            | IN-DIA  | 108            | \$ 45.00     | \$ 4,860.00   |
| 4      | TREE TRUNK PROTECTION   | EACH    | 94             | \$ 10.00     | \$ 940.00     |
| 5      | M.H., C.B., V.V., TO BE REMOVED                                 | EACH    | 19             | \$ 500.00    | \$ 9,500.00   |
| 6      | ABANDON EXISTING VALVE AND VAULT                                | EACH    | 13             | \$ 600.00    | \$ 7,800.00   |
| 7      | C.B., TY-C, 2' DIA., CURB FRAME & HIGH FLOW GRATE               | EACH    | 18             | \$ 3,600.00  | \$ 64,800.00  |
| 8      | C.B., TY-C, 2' DIA., BEEHIVE GRATE                              | EACH    | 1              | \$ 3,400.00  | \$ 3,400.00   |
| 9      | C.B., TY-C, 4' DIA., CURB FRAME & HIGH FLOW GRATE               | EACH    | 4              | \$ 5,750.00  | \$ 23,000.00  |
| 10     | C.B., TY-C, 4' DIA., BEEHIVE GRATE                              | EACH    | 2              | \$ 5,500.00  | \$ 11,000.00  |
| 11     | M.H.,C.B.,V.V. TO BE ADJUSTED, NEW FRAME & LID                  | EACH    | 25             | \$ 1,075.00  | \$ 26,875.00  |
| 12     | M.H.,C.B.,V.V. TO BE RECONSTRUCTED, NEW FRAME & LID             | EACH    | 11             | \$ 2,600.00  | \$ 28,600.00  |
| 13     | STORM MANHOLE, TY-A, 4' DIA, ROUND FRAME & CLOSED LID           | EACH    | 9              | \$ 5,800.00  | \$ 52,200.00  |
| 14     | STORM MANHOLE, TY-A, 5' DIA, ROUND FRAME & CLOSED LID           | EACH    | 1              | \$ 8,200.00  | \$ 8,200.00   |
| 15     | SANITARY MANHOLE, TY-A, 4' DIA, ROUND FRAME & CLOSED LID        | EACH    | 2              | \$ 8,800.00  | \$ 17,600.00  |
| 16     | SAN. M.H. TO BE ADJUSTED, NEW FRAME & LID                       | EACH    | 10             | \$ 1,200.00  | \$ 12,000.00  |
| 17     | SAN. M.H. TO BE RECONSTRUCTED, NEW FRAME & LID                  | EACH    | 5              | \$ 2,100.00  | \$ 10,500.00  |
| 18     | FIRE HYDRANT REMOVAL  | EACH    | 12             | \$ 1,000.00  | \$ 12,000.00  |
| 19     | FIRE HYDRANT AND AUXILIARY VALVE                                | EACH    | 16             | \$ 10,800.00 | \$ 172,800.00 |
| 20     | WATER MAIN, 6 INCH DUCTILE IRON PIPE, CL 52                     | FOOT    | 34             | \$ 145.00    | \$ 4,930.00   |
| 21     | WATER MAIN, 8 INCH DUCTILE IRON PIPE, CL 52                     | FOOT    | 3,024          | \$ 222.25    | \$ 672,084.00 |
| 22     | WATER MAIN, 10 INCH DUCTILE IRON PIPE, CL 52                    | FOOT    | 1,464          | \$ 238.25    | \$ 348,798.00 |
| 23     | WATER MAIN, CARRIER PIPE, 8 INCH DUCTILE IRON PIPE, CL 52       | FOOT    | 33             | \$ 145.00    | \$ 4,785.00   |
| 24     | WATER MAIN, CARRIER PIPE, 10 INCH DUCTILE IRON PIPE, CL 52      | FOOT    | 20             | \$ 175.00    | \$ 3,500.00   |
| 25     | CASING PIPE, 16" PVC C-900                                      | FOOT    | 53             | \$ 140.00    | \$ 7,420.00   |
| 26     | CASING SPACERS, ALL SIZES                                       | EACH    | 8              | \$ 250.00    | \$ 2,000.00   |
| 27     | PUBLIC WATER SERVICE LINE, COPPER, 1 INCH                       | FOOT    | 62             | \$ 1.00      | \$ 62.00      |
| 28     | PRIVATE WATER SERVICE LINE, COPPER, 1 INCH                      | FOOT    | 1,375          | \$ 1.00      | \$ 1,375.00   |
| 29     | PUBLIC WATER SERVICE LINE, COPPER, 1 1/2 INCH                   | FOOT    | 2,682          | \$ 0.10      | \$ 268.20     |
| 30     | PUBLIC WATER SERVICE LINE, COPPER, 2 INCH                       | FOOT    | 30             | \$ 85.00     | \$ 2,550.00   |
| 31     | WATER SERVICE SADDLE, 1 1/2 INCH                                | EACH    | 85             | \$ 975.00    | \$ 82,875.00  |
| 32     | WATER SERVICE SADDLE, 2 INCH                                    | EACH    | 1              | \$ 1,200.00  | \$ 1,200.00   |
| 33     | CORPORATION STOP, 1 1/2 INCH                                    | EACH    | 85             | \$ 2,200.00  | \$ 187,000.00 |
| 34     | CORPORATION STOP, 2 INCH  | EACH    | 1              | \$ 3,200.00  | \$ 3,200.00   |
| 35     | CURB STOP, 1 1/2 INCH   | EACH    | 85             | \$ 2,100.00  | \$ 178,500.00 |
| 36     | CURB STOP, 2 INCH   | EACH    | 1              | \$ 1,500.00  | \$ 1,500.00   |
| 37     | CURB BOX, 1 1/2 INCH  | EACH    | 85             | \$ 375.00    | \$ 31,875.00  |
| 38     | CURB BOX, 2 INCH  | EACH    | 1              | \$ 375.00    | \$ 375.00     |
| 39     | PRIVATE WATER SERVICE FOUNDATION CONNECTION                     | EACH    | 35             | \$ 10.00     | \$ 350.00     |
| 40     | PRIVATE WATER SERVICE METER CONNECTION                          | EACH    | 35             | \$ 10.00     | \$ 350.00     |
| 41     | GATE VALVE, 8 INCH, 48 INCH DIA VAULT, ROUND FRAME, CLOSED LID  | EACH    | 12             | \$ 7,800.00  | \$ 93,600.00  |
| 42     | GATE VALVE, 10 INCH, 60 INCH DIA VAULT, ROUND FRAME, CLOSED LID | EACH    | 5              | \$ 9,800.00  | \$ 49,000.00  |
| 43     | WATER MAIN FITTINGS, RESTRAINED JOINT                           | POUND   | 8,050          | \$ 0.01      | \$ 80.50      |
| 44     | PIPE REMOVAL, ALL SIZES AND TYPES                               | FOOT    | 514            | \$ 5.00      | \$ 2,570.00   |
| 45     | STORM SEWER, DUCTILE IRON PIPE, 12 INCH, CL 52                  | FOOT    | 958            | \$ 251.25    | \$ 240,697.50 |
| 46     | STORM SEWER, REIFORCED CONCRETE PIPE, 18 INCH,                  | FOOT    | 576            | \$ 222.25    | \$ 128,016.00 |
| 47     | STORM SEWER REPAIR, REMOVE AND REPLACE, 12" DIP                 | FOOT    | 14             | \$ 250.00    | \$ 3,500.00   |
| 48     | SANITARY SEWER, REMOVE AND REPLACE, 8" PVC, C-900               | FOOT    | 20             | \$ 200.00    | \$ 4,000.00   |
| 49     | SANITARY SEWER, REMOVE AND REPLACE, 12" PVC, C-900              | FOOT    | 40             | \$ 225.00    | \$ 9,000.00   |
| 50     | SANITARY SEWER WYE FITTING, PVC, ALL SIZES                      | EACH    | 8              | \$ 100.00    | \$ 800.00     |
| 51     | SANITARY SEWER LINING, 12 INCH                                  | FOOT    | 957            | \$ 60.00     | \$ 57,420.00  |
| 52     | SANITARY SEWER LINING, 15 INCH                                  | FOOT    | 297            | \$ 85.00     | \$ 25,245.00  |
| 53     | SANITARY SEWER LINING, 18 INCH                                  | FOOT    | 728            | \$ 108.00    | \$ 78,624.00  |
| 54     | SANITARY SEWER LATERAL REPAIR, REMOVE & REPLACE, 6 INCH WQP     | FOOT    | 97             | \$ 125.00    | \$ 12,125.00  |
| 55     | TRENCH BACKFILL   | CU.YD.  | 8,375          | \$ 0.10      | \$ 837.50     |
| 56     | SIDEWALK REMOVAL  | SQ. FT. | 27,470         | \$ 2.00      | \$ 54,940.00  |
| 57     | P.C.C. SIDEWALK   | SQ. FT. | 32,350         | \$ 10.00     | \$ 323,500.00 |
| 58     | DETECTABLE WARNINGS   | SQ. FT. | 740            | \$ 35.00     | \$ 25,900.00  |

## 2026 CIP WATER MAIN IMPROVEMENTS - CONTRACT A SCHEDULE OF PRICES - ADDENDUM #1

| ITEM # | PAY ITEM  | UNIT         | TOTAL QUANTITY | UNIT COST        | TOTAL COST             |
|--------|---|--------------|----------------|------------------|------------------------|
| 59     | REINFORCEMENT BARS, EPOXY COATED                        | FOOT         | 2,430          | \$ 1.50          | \$ 3,645.00            |
| 60     | DRIVEWAY PAVEMENT REM. & P.C.C. REPL., 6 INCH           | SQ. YD.      | 1,585          | \$ 118.00        | \$ 187,030.00          |
| 61     | DRIVEWAY PAVEMENT REM. & P.C.C. REPL., 8 INCH           | SQ. YD.      | 780            | \$ 142.00        | \$ 110,760.00          |
| 62     | REMOVE AND RESET BRICK PAVER DRIVEWAY APRON             | SQ. YD.      | 35             | \$ 60.00         | \$ 2,100.00            |
| 63     | COMB. CONCRETE CURB AND GUTTER REMOVAL                  | FOOT         | 7,955          | \$ 7.00          | \$ 55,685.00           |
| 64     | COMB. CONCRETE CURB AND GUTTER REPLACEMENT              | FOOT         | 9,605          | \$ 32.00         | \$ 307,360.00          |
| 65     | CURB KEYWAY   | FOOT         | 1,075          | \$ 2.00          | \$ 2,150.00            |
| 66     | TEMPORARY AGGREGATE, CA-6                               | TON          | 680            | \$ 1.00          | \$ 680.00              |
| 67     | PAVEMENT PATCHING, 6 INCH                               | SQ. YD.      | 655            | \$ 1.00          | \$ 655.00              |
| 68     | PAVEMENT REMOVAL, 14 INCHES                             | SQ. YD.      | 14,180         | \$ 24.00         | \$ 340,320.00          |
| 69     | EARTH EXCAVATION  | CU.YD.       | 2,950          | \$ 1.00          | \$ 2,950.00            |
| 70     | EARTH EXCAVATION - WIDENING                             | CU.YD.       | 935            | \$ 55.00         | \$ 51,425.00           |
| 71     | GEOTECHNICAL FABRIC FOR GROUND STABILIZATION            | SQ. YD.      | 16,476         | \$ 2.00          | \$ 32,952.00           |
| 72     | GRANULAR EMBANKMENT                                     | CU.YD.       | 1,600          | \$ 1.00          | \$ 1,600.00            |
| 73     | POROUS GRANULAR EMBANKMENT                              | CU.YD.       | 530            | \$ 1.00          | \$ 530.00              |
| 74     | AGGREGATE BASE COURSE, TYPE B, 8 INCH                   | SQ. YD.      | 14,455         | \$ 14.00         | \$ 202,370.00          |
| 75     | TEMPORARY PAVEMENT PATCH                                | TON          | 65             | \$ 10.00         | \$ 650.00              |
| 76     | DRIVEWAY HMA SURFACE COURSE REMOVAL AND REPLACEMENT     | SQ. YD.      | 235            | \$ 65.00         | \$ 15,275.00           |
| 77     | HOT MIX ASPHALT BINDER COURSE, IL-19, N50, 4 INCH       | TON          | 3,480          | \$ 85.50         | \$ 297,540.00          |
| 78     | LEVELING BINDER (HAND METHOD), N50                      | TON          | 280            | \$ 1.00          | \$ 280.00              |
| 79     | BITUMINOUS MATERIALS (PRIME COAT)                       | GAL.         | 1,033          | \$ 1.00          | \$ 1,033.00            |
| 80     | AGGREGATE (PRIME COAT)                                  | TON          | 15             | \$ 15.00         | \$ 225.00              |
| 81     | HOT MIX ASPHALT SURFACE COURSE, MIX D, N50, 2 INCH      | TON          | 1,740          | \$ 93.00         | \$ 161,820.00          |
| 82     | GRADING AND SHAPING PARKWAYS                            | SQ. YD.      | 8,600          | \$ 8.50          | \$ 73,100.00           |
| 83     | TOPSOIL PLACEMENT, 4 INCH AND SODDING                   | SQ. YD.      | 8,600          | \$ 18.00         | \$ 154,800.00          |
| 84     | THERMOPLASTIC PVMT. MARKING LINE, 4 INCH                | FOOT         | 2,912          | \$ 2.00          | \$ 5,824.00            |
| 85     | THERMOPLASTIC PVMT. MARKING LINE, 6 INCH                | FOOT         | 1,378          | \$ 2.25          | \$ 3,100.50            |
| 86     | THERMOPLASTIC PVMT. MARKING LINE, 12 INCH               | FOOT         | 408            | \$ 5.00          | \$ 2,040.00            |
| 87     | THERMOPLASTIC PVMT. MARKING LINE, 24 INCH               | FOOT         | 306            | \$ 9.00          | \$ 2,754.00            |
| 88     | THERMOPLASTIC PVMT. MARKING LINE, LETTERS AND SYMBOLS   | SQ. FT.      | 23             | \$ 15.00         | \$ 345.00              |
| 89     | POLYUREA PVMT. MARKING LINE, 4 INCH                     | FOOT         | 63             | \$ 4.00          | \$ 252.00              |
| 90     | POLYUREA PVMT. MARKING LINE, 12 INCH                    | FOOT         | 438            | \$ 10.00         | \$ 4,380.00            |
| 91     | POLYUREA PVMT. MARKING LINE, 24 INCH                    | FOOT         | 72             | \$ 18.00         | \$ 1,296.00            |
| 92     | POLYUREA PVMT. MARKING LINE, LETTERS AND SYMBOLS        | SQ. FT.      | 74             | \$ 18.00         | \$ 1,332.00            |
| 93     | REMOVE SIGN PANEL ASSEMBLY                              | EACH         | 20             | \$ 200.00        | \$ 4,000.00            |
| 94     | TELESCOPING STEEL SIGN SUPPORT                          | FOOT         | 330            | \$ 25.00         | \$ 8,250.00            |
| 95     | SIGN PANEL, TYPE 1                                      | SQ. FT.      | 92             | \$ 45.00         | \$ 4,140.00            |
| 96     | RELOCATE SIGN PANEL ASSEMBLY                            | EACH         | 16             | \$ 225.00        | \$ 3,600.00            |
| 97     | PORTABLE TOILETS  | EA. CAL. MO. | 11             | \$ 400.00        | \$ 4,400.00            |
| 98     | CONTRACTOR'S FURNISHED CONSTRUCTION LAYOUT              | LUMP SUM     | 1              | \$ 137,213.00    | \$ 137,213.00          |
| 99     | TRAFFIC CONTROL AND PROTECTION                          | LUMP SUM     | 1              | \$ 627,500.00    | \$ 627,500.00          |
| 100    | ITEMS AS DIRECTED BY THE ENGINEER - LEAD WATER SERVICES | DOL          | 100,000        | \$ 1.00          | \$ 100,000.00          |
|        |   |              |                | <b>TOTAL BID</b> | <b>\$ 6,028,939.20</b> |

**CITY OF DES PLAINES  
CONTRACT FOR THE CONSTRUCTION OF  
2026 CIP WATER MAIN IMPROVEMENTS - CONTRACT A**

**ATTACHMENT 2**

**SUPPLEMENTAL SCHEDULE OF CONTRACT TERMS**

**1. Project:**

*Project Description*

**The project scope includes installation of new water main and service connections, abandonment or removal of old water main pipe, repair and replacement of storm catch basins, replacement and/or lining of various existing storm and sanitary sewers, street rehabilitation or reconstruction, curb and gutter replacement, driveway apron replacement, miscellaneous sidewalk repairs, regrading of parkways, and miscellaneous landscaping restoration.**

**2. Work Site:**

**Birch Street (Touhy Av to North End)  
Fifth Avenue (Prospect Av to Algonquin Rd)  
Prairie Avenue (Fifth Av to Second Av)**

**3. Permits, Licenses, Approvals, and Authorizations:**

Contractor must obtain all required governmental permits, licenses, approvals, and authorizations, except:



**[Identify permits, licenses, and approvals obtained, or to be obtained, by Owner]**

IEPA – Public Water Supplies Construction Permit

MWRD – Notification and Request For Inspection (NRI) Sewer Replacement Permit

MWRD – Watershed Management Ordinance (WMO) Permit



No Exceptions

**4. Commencement Date:**



the date of execution of the Contract by Owner.

\_\_\_\_\_ 10 \_\_\_\_\_ days after execution of the Contract by Owner.

[Click here to enter a date.](#)

**5. Completion Date:**

**Starting and Substantial Completion Dates:**

The following starting and substantial completion dates apply to this contract as designated by street:

\_\_\_\_\_ days after the Commencement Date plus extensions, if any, authorized by a Change Order issued pursuant to Subsection 2.2A of the Contract

**Friday, November 20, 2026**, plus extensions, if any, authorized by a Change Order issued pursuant to Subsection 2.2A of the Contract

Completion includes the approved and acceptable construction of all pay items: including concrete correction (punch) list items, all hot-mix asphalt items including surface courses and all landscape restoration work, including topsoil and sod placement.

| STREET     | LIMIT                     | START DATE | SUBSTANTIAL COMPLETION DATE |
|------------|---------------------------|------------|-----------------------------|
| Fifth Av   | Forest Av to Algonquin Rd | 5/18/2026  | 8/21/2026                   |
| Birch St   | Touhy Av to north end     | 6/17/2026  | 10/23/2026                  |
| Prairie Av | Fifth Av to Second Av     | 7/6/2026   | 11/20/2026                  |

**Days and Hours of Work.** Workdays for this Contract are Monday through Friday between the hours of **7AM to 6PM**. No work shall be done or equipment operated outside of these permitted hours. **NO WORK SHALL BE DONE ON ANY SATURDAYS, SUNDAYS OR CITY HOLIDAYS** listed below unless otherwise approved in writing by the Project Manager.

- Monday, May 25, 2026**
- Friday, July 03, 2026**
- Monday, September 07, 2026**
- Monday, October 12, 2026,**
- Wednesday, November 11, 2026**
- Thursday, November 26, 2026**
- Friday, November 27, 2026**

- Memorial Day Holiday**
- Independence Day Holiday (observed)**
- Labor Day Holiday**
- Columbus Day Holiday**
- Veterans Day Holiday**
- Thanksgiving Day Holiday**
- Day After Thanksgiving Day Holiday**

If work is approved and the Contractor works on Saturday, Sunday, or holiday, during which time the Engineer and/or Inspector(s) are required to be present, the City of Des Plaines shall assess a fee for overtime services per day worked:

|           | Saturday   | Sunday     | Holidays   |
|-----------|------------|------------|------------|
| Engineer  | \$1,000.00 | \$1,200.00 | \$1,500.00 |
| Inspector | \$ 800.00  | \$1,000.00 | \$1,200.00 |

Fees for such overtime engineering services will be deducted from payments due the Contractor.

**Progress Schedule.** The Contractor shall submit, for approval by the Engineer, a Progress Schedule, which complies with the requirements of these specifications, and Completion Dates. The Progress Schedule shall include an Estimate of Time and/or Performance Rate for each controlling pay item. Once a Progress Schedule is approved, there shall be no deviation without the written approval of the Engineer.

**If the Contractor falls 10 or more working days behind the Approved Progress Schedule, they shall provide the Engineer with a revised Progress Schedule that complies with the requirements of the Contract for the Engineer's review.**

**TIME IS OF THE ESSENCE ON THIS CONTRACT AND LIQUIDATED DAMAGES WILL BE ASSESSED FOR EACH DAY THAT THE WORK REMAINS INCOMPLETE PAST THE STATED COMPLETION DATE.**

**6. Insurance Coverage:**

A. Worker's Compensation and Employer's Liability with limits not less than:

- (1) Worker's Compensation: Statutory;
- (2) Employer's Liability: \$1,000,000 injury-per occurrence; \$1,000,000 disease-per employee; \$1,000,000 disease-policy limit

Such insurance must evidence that coverage applies in the State of Illinois.

B. Comprehensive Motor Vehicle Liability with a combined single limit of liability for bodily injury and property damage of not less than \$2,000,000 for vehicles owned, non-owned, or rented.

All employees must be included as insureds.

C. Comprehensive General Liability with coverage written on an "occurrence" basis and with limits no less than:

- (1) General Aggregate: \$5,000,000. See Subsection F below regarding use of umbrella coverage.
- (2) Bodily Injury: \$2,000,000 per person; \$2,000,000 per occurrence
- (3) Property Damage: \$2,000,000 per occurrence and \$5,000,000 aggregate.

Coverage must include:

- Premises / Operations
- Products / Completed Operations (to be maintained for two years after Final Payment)
- Independent Contractors
- Personal Injury (with Employment Exclusion deleted)
- Broad Form Property Damage Endorsement
- Blanket Contractual Liability (must expressly cover the indemnity provisions of the Contract)
- Bodily Injury and Property Damage

“X”, “C”, and “U” exclusions must be deleted.

Railroad exclusions must be deleted if Work Site is within 50 feet of any railroad track.

All employees must be included as insured.



D. Builders Risk Insurance. This insurance must be written in completed value form, must protect Contractor and Owner against “all risks” of direct physical loss to buildings, structures, equipment, and materials to be used in providing, performing, and completing the Work, including without limitation fire extended coverage, vandalism and malicious mischief, sprinkler leakage, flood, earth movement and collapse, and must be designed for the circumstances that may affect the Work.

This insurance must be written with limits not less than the insurable value of the Work at completion. The insurable value must include the aggregate value of Owner-furnished equipment and materials to be constructed or installed by Contractor.

This insurance must include coverage while equipment or materials are in warehouses, during installation, during testing, and after the Work is completed, but prior to Final Payment. This insurance must include coverage while Owner is occupying all or any part of the Work prior to Final Payment without the need for the insurance company’s consent.

E. Owner's and Contractor's Protective Liability Insurance. Contractor, at its sole cost and expense, must purchase this Insurance in the name of Owner with a combined single limit for bodily injury and property damage of not less than \$1,000,000.

F. Umbrella Policy. The required coverage may be in the form of an umbrella policy above \$2,000,000 primary coverage. All umbrella policies must provide excess coverage over underlying insurance on a following-form basis so that, when any loss covered by the primary policy exceeds the limits under the primary policy, the excess or umbrella policy becomes effective to cover that loss.

G. Deductible. Each policy must have a deductible or self-insured retention of not more than \$ \_\_\_\_\_.

H. Owner as Additional Insured. Owner must be named as an Additional Insured on the following policies:  
Comprehensive General Liability, Comprehensive Motor Vehicle Liability, and Umbrella Policy.

The Additional Insured endorsement must identify Owner as follows:

The City of Des Plaines and its boards, commissions, committees, authorities, employees, agencies, officers, voluntary associations, and other units operating under the jurisdiction and within the appointment of its budget.

I. Other Parties as Additional Insureds. In addition to Owner, the following parties must be named as additional insured on the following policies:

| <u>Additional Insured</u> | <u>Policy or Policies</u> |
|---------------------------|---------------------------|
|---------------------------|---------------------------|

7. **Contract Price:**

**SCHEDULE OF PRICES**

B. UNIT PRICE CONTRACT

NOTE: If Owner has provided a separate form Schedule of Pricing attached to this Attachment 1, then that Schedule of Prices will be used and this Subsection

B should not be used. If Owner has not provided a separate form Schedule of Prices, then this Subsection B should be used.

For providing, performing, and completing all Work, the sum of the products resulting from multiplying the number of acceptable units of Unit Price Items listed below incorporated in the Work by the Unit Price set forth below for such Unit Price Item:

**COMPLETE SCHEDULE OF PRICES  
SEE ATTACHMENT 1**

Any items of Work not specifically listed or referred to in the Schedule of Prices, or not specifically included for payment under any Unit Price Item, shall be deemed incidental to the Contract Price, shall not be measured for payment, and shall not be paid for separately except as incidental to the Contract Price, including without limitation extraordinary equipment repair, the cost of transportation, packing, cartage, and containers, the cost of preparing schedules and submittals, the cost or rental of small tools or buildings, the cost of utilities and sanitary conveniences, and any portion of the time of Bidder, its superintendents, or its office and engineering staff.

**8. Progress Payments:**

- A. General. Owner must pay to Contractor 90 percent of the Value of Work, determined in the manner set forth below, installed and complete in place up to the day before the Pay Request, less the aggregate of all previous Progress Payments. The total amount of Progress Payments made prior to Final Acceptance by Owner may not exceed 90 percent of the Contract Price.
- B. Value of Work. The Value of the Work will be determined as follows:
- (1) Lump Sum Items. For all Work to be paid on a lump sum basis, Contractor must, not later than 10 days after execution of the Contract and before submitting its first Pay Request, submit to Owner a schedule showing the value of each component part of such Work in form and with substantiating data acceptable to Owner (“Breakdown Schedule”). The sum of the items listed in the Breakdown Schedule must equal the amount or amounts set forth in the Schedule of Prices for Lump Sum Work. An unbalanced Breakdown Schedule providing for overpayment of Contractor on component parts of the Work to be performed first will not be accepted. The Breakdown Schedule must be revised and resubmitted until acceptable to Owner. No payment may be made for any lump sum item until Contractor has submitted, and Owner has approved, an acceptable Breakdown Schedule.

Owner may require that the approved Breakdown Schedule be revised based on developments occurring during the provision and performance of the Work. If Contractor fails to submit a revised Breakdown Schedule that is acceptable to Owner, Owner will have the right either to suspend Progress and Final Payments for Lump Sum Work or to make such Payments based on Owner's determination of the value of the Work completed.

- (2) Unit Price Items. For all Work to be paid on a unit price basis, the value of such Work will be determined by Owner on the basis of the actual number of acceptable units of Unit Price Items installed and complete in place, multiplied by the applicable Unit Price set forth in the Schedule of Prices. The actual number of acceptable units installed and complete in place will be measured on the basis described in Attachment 1 to the Contract or, in the absence of such description, on the basis determined by Owner. The number of units of Unit Price Items stated in the Schedule of Prices are Owner's estimate only and may not be used in establishing the Progress or Final Payments due Contractor. The Contract Price will be adjusted to reflect the actual number of acceptable units of Unit Price Items installed and complete in place upon Final Acceptance.

- C. Application of Payments. All Progress and Final Payments made by Owner to Contractor will be applied to the payment or reimbursement of the costs with respect to which they were paid and will not be applied to or used for any pre-existing or unrelated debt between Contractor and Owner or between Contractor and any third party.

9. **Per Diem Administrative Charge:**

\$ per IDOT SSRB

No Charge

10. **Standard Specifications:**

The Contract includes the following Illinois Department of Transportation standard specifications, each of which are incorporated into the Contract by reference:

"State of Illinois Standard Specifications for Road and Bridge Construction" (SSRB)

- "Standard Specifications for Water and Sewer Main Construction in Illinois" (SSWS)
- "Illinois Manual on Uniform Traffic Control Devices for Streets and Highways" (MUTCD).

The Contract also includes Owner's City Code and Building Codes.

References to any of these manuals, codes, and specifications means the latest editions effective on the date of the bid opening.

See Attachment 5 for any special project requirements.

**CITY OF DES PLAINES  
 CONTRACT FOR THE CONSTRUCTION OF  
 2026 CIP WATER MAIN IMPROVEMENTS - CONTRACT A**

**ATTACHMENT 3**

**SPECIFICATIONS**

**INDEX OF SPECIAL PROVISIONS**

The following Index is provided for the Bidder's convenience only. Bidders are advised to thoroughly read each Special Provision and familiarize themselves with their content.

| <b><u>PAGE</u></b> | <b><u>DESCRIPTION</u></b>                             |
|--------------------|---|
| 1                  | SPECIAL PROVISIONS                                    |
| 1                  | CONTRACTOR SAFETY RESPONSIBILITY                      |
| 1                  | COOPERATION BY CONTRACTOR                             |
| 2                  | DIRT ON PAVEMENT                                      |
| 2                  | OBSTRUCTION OF STREETS AND RIGHTS OF WAY              |
| 2                  | TESTING OF MATERIALS                                  |
| 3                  | RECORD DRAWING SURVEY POINT FILE                      |
| 4                  | EXPLORATION TRENCH                                    |
| 4                  | WATER MAIN CONNECTIONS AND SHUT DOWNS                 |
| 5                  | DUCTILE IRON PIPE WATER MAIN, CLASS 52                |
| 6                  | GATE VALVE, VAULT, FRAME AND CLOSED LID               |
| 7                  | FIRE HYDRANT REMOVAL                                  |
| 8                  | FIRE HYDRANT AND AUXILIARY VALVE                      |
| 9                  | WATER MAIN RESTRAINED JOINT FITTINGS                  |
| 10                 | WATER MAIN CHLORINATION AND TESTING                   |
| 11                 | WATER SERVICE LINE, COPPER                            |
| 12                 | WATER SERVICE SADDLES                                 |
| 13                 | CORPORATION STOP                                      |
| 14                 | CURB STOP   |
| 14                 | CURB BOX  |
| 15                 | PRIVATE WATER SERVICE FOUNDATION CONNECTION           |
| 16                 | PRIVATE WATER SERVICE METER CONNECTION                |
| 18                 | ITEMS AS DIRECTED BY THE CITY (LEAD SERVICES)         |
| 18                 | ABANDON EXISTING VALVE AND VAULT                      |
| 19                 | DES PLAINES UTILITY STRUCTURE FRAMES, LIDS AND GRATES |

|    |  |
|----|--|
| 20 | CASING PIPE  |
| 21 | CASING SPACERS   |
| 22 | PIPE REMOVAL, ALL TYPES AND SIZES  |
| 22 | STORM MANHOLE AND CATCH BASIN CONSTRUCTION                               |
| 23 | STORM SEWER, DUCTILE IRON PIPE   |
| 24 | MANHOLE, CATCH BASIN, VALVE VAULT ADJUSTMENT AND RECONSTRUCTION          |
| 25 | SANITARY MANHOLE, TYPE A, NEW FRAME, CLOSED LID                          |
| 26 | SANITARY MANHOLE ADJUSTMENT AND RECONSTRUCTION                           |
| 27 | SANITARY SEWER MAIN AND LATERAL REPAIR                                   |
| 28 | TRENCH BACKFILL  |
| 29 | SEWER LINING WITH CURED-IN-PLACE PIPE LINER                              |
| 36 | SIDEWALK REMOVAL, PORTLAND CEMENT CONCRETE SIDEWALK, DETECTABLE WARNINGS |
| 37 | REINFORCEMENT BARS, EPOXY COATED   |
| 38 | DRIVEWAY PAVEMENT REMOVAL AND REPLACEMENT IN PORTLAND CEMENT CONCRETE    |
| 39 | REMOVE AND RESET BRICK PAVER DRIVEWAY APRON                              |
| 40 | COMBINATION CONCRETE CURB AND GUTTER REMOVAL AND REPLACEMENT             |
| 41 | CURB KEYWAY  |
| 42 | TEMPORARY AGGREGATE, CA-6  |
| 42 | PAVEMENT PATCHING  |
| 43 | PAVEMENT REMOVAL, 14"  |
| 44 | AGGREGATE BASE COURSE, TYPE B  |
| 44 | TEMPORARY PAVEMENT PATCH   |
| 45 | HOT-MIX ASPHALT DRIVEWAY SURFACE COURSE REMOVAL AND REPLACEMENT          |
| 45 | GRADING AND SHAPING PARKWAYS AND DITCHES                                 |
| 46 | TOPSOIL PLACEMENT 4 INCHES AND SODDING                                   |
| 47 | REMOVE SIGN PANEL ASSEMBLY   |
| 47 | TELESCOPING STEEL SIGN SUPPORT   |
| 48 | SIGN PANEL, TYPE 1   |
| 49 | PORTABLE TOILETS   |
| 49 | TRAFFIC CONTROL AND PROTECTION   |

OTHER ATTACHMENTS:

INDEX FOR SUPPLEMENTAL SPECIFICATIONS AND RECURRING SPECIAL PROVISIONS

CHECK SHEET FOR RECURRING SPECIAL PROVISIONS

BDE SPECIAL PROVISIONS

LOCAL ROADS SPECIAL PROVISIONS

(CONT.)

TRENCH BACKFILL TABLES  
NO PARKING SIGN  
HIGHWAY STANDARDS  
STORM WATER POLLUTION PREVENTION PLAN  
SOIL BORINGS AND CORES

**CITY OF DES PLAINES  
 CONTRACT FOR THE CONSTRUCTION OF  
 2026 CIP WATER MAIN IMPROVEMENTS - CONTRACT A**

**ATTACHMENT 4**

LIST OF DRAWINGS

| INDEX OF SHEETS |                                      |
|-----------------|--------------------------------------|
| Sheet No.       | Description                          |
| 1               | COVER SHEET                          |
| 2               | LEGEND, ABBREVIATIONS                |
| 3               | SUMMARY OF QUANTITIES, GENERAL NOTES |
| 4               | MWRD GENERAL NOTES                   |
| 5               | TYPICAL SECTIONS                     |
| 6 - 8           | BIRCH STREET                         |
| 9 - 11          | FIFTH AVENUE                         |
| 12 - 15         | PRAIRIE AVENUE                       |
| 16 - 17         | PRAIRIE AVENUE PAVEMENT ELEVATIONS   |
| 18 - 19         | TYPICAL DETAILS                      |
| 20              | EROSION AND SEDIMENT CONTROL DETAILS |

**CITY OF DES PLAINES  
CONTRACT FOR THE CONSTRUCTION OF  
2026 CIP WATER MAIN IMPROVEMENTS - CONTRACT A**

**ATTACHMENT 5**

**SPECIAL PROJECT REQUIREMENTS**

**ACCELERATED SHOP DRAWING SUBMITTALS**

Due to potential material shortages and delays, the City requires that all shop drawings, catalog cuts and other material certifications that affect critical path items be submitted NO LATER THAN 5 DAYS after the Notice to Proceed is executed.

**PRE-CONSTRUCTION MEETING**

Prior to commencing any construction operations, there shall be a Pre-Construction Meeting conducted at the Public Works and Engineering Office, Des Plaines Civic Center, 1420 Miner Street, Room 504. The Engineer will set the date and time of the Pre-Construction Meeting after execution of the Contract by both parties. The Contractor's full time Superintendent must attend the Pre-Construction meeting.

The following shall be submitted for review at the Pre-Construction meeting:

Progress Schedule (submit 3 working days prior) for review

Superintendent 24-hour emergency phone number, field phone number, pager number and cellular telephone number

Name and 24-hour emergency telephone number of the person in the direct employ of the Contractor who is responsible for administering the Traffic Control on the Contract.

List of Subcontractors, including quantity and type of work to be sublet, their qualifications, references and certified copies of their subcontract agreements.

List of Material Suppliers and phone numbers

Mix Designs for concrete and hot-mix asphalt items to be incorporated in the Contract

All Subcontractors are required to either attend the Pre-Construction meeting or attend a Field Pre-Construction meeting with the Resident Engineer and the Contractor's Superintendent prior to the beginning of any sub-let work.

## **CLAIMS**

The Contractor agrees to save and hold harmless the Owner and the Engineer from all claims, demands, suits, judgment decrees, including costs, expenses and attorney fees on account of, or arising out of the use of the streets or sidewalks, or resulting from the excavations, openings, obstructions, or defects that may be made or left in the streets or sidewalks by the Contractor or their several agents, or any other person engaged in the performance of this Contract.

The Contractor shall save the Owner and the Engineer harmless from all claims, demands, suits, judgment decrees, including costs, expenses and attorney fees on account of, or arising out of any infringement of any patent rights or royalties claimed by any one on account of machinery, instrument tools, materials, principals or processes used by them or about said work.

### **PROCEDURE FOR RESOLVING PROPERTY DAMAGE CLAIMS**

The General Contractor agrees to adhere to the following procedure to resolve all property damage claims that are related to the performance of all Work on this Contract. It is the responsibility of the General Contractor to require that all Subcontractors and Material Suppliers follow this claim procedure. The City reserves the right to withhold one and one half times the estimated cost of the damages from sums due the General Contractor until all claims related to performance of their Work are resolved as herein provided.

Upon receipt of a claim against the General Contractor for property damage allegedly caused or related to the performance of their Work under this Contract, the General Contractor shall, within 5 working days of receipt of such claim:

Acknowledge the claim, in writing, to the property owner.

Furnish the Engineer with written acknowledgement of receipt of the claim, including a copy of the claim and all information related to it.

If the claim is not settled (or the General Contractor does not agree to settle the claim) within 5 days, the General Contractor shall:

Forward the claim to the General Contractor's Insurance Carrier.

Furnish the Engineer with a copy of the Insurance Carrier's written acknowledgement of receipt of the claim

The General Contractor shall either settle or deny the claim within 60 calendar days from initial receipt of the claim, the General Contractor shall:

Notify the Engineer, in writing, of claims that have been settled or denied, including the terms of the settlement or the reason for the denial.

Notify the property owner if there is a decision to deny their claim and shall include in the Notice of Denial the name and address of the person authorized to accept service of process on behalf of the General Contractor.

When a claim is allowed in any amount, within 30 days of the award, pay to the property owner the amount of the award.

If the Contractor does not make payment to the property owner within the 30 day period, the Owner shall be authorized to make the payment in the amount of the award on behalf of the General Contractor and deduct the amount of the payment from the amount due the General Contractor on the next payment due the Contractor under this Contract.



**PUBLIC WORKS AND  
ENGINEERING DEPARTMENT**

1111 Joseph J. Schwab Road  
Des Plaines, IL 60016  
P: 847-391-5464  
desplainesil.gov

**MEMORANDUM**

Date: April 23, 2026  
To: Dorothy Wisniewski, City Manager  
From: David Schilf, Superintendent   
Cc: Timothy Watkins, Director of Public Works and Engineering  
Tom Bueser, Assistant Director of Public Works  
Subject: M.E. Simpson Task Order #3 – Large Meter Testing

**Issue:** The 2026 budget includes funding for large water meter testing.

**Analysis:** Public Works annually files a water loss report to the IDNR. The mandated rules for this report have changed in recent years and we are now required to perform additional audit functions. This includes large meter testing and in-depth analysis of the City's metering and billing systems. This task will assist the City in identifying water loss.

The City has a Master Consultant Agreement with M.E. Simpson Company, Inc. and they have provided a proposal to perform the above tasks on large meters. Their proposal for Task Order #3 is in the amount of \$91,000.00.

**Recommendation:** We recommend approval of Task Order #3 with M.E. Simpson Company, Inc., 3406 Enterprise Avenue, Valparaiso, IN, 46383, in the amount of \$91,000.00. Funding source will be the Water Fund.

**Attachments:**

Resolution R-124-26  
Exhibit A – Task Order #3

CITY OF DES PLAINES

RESOLUTION R - 124 - 26

**A RESOLUTION APPROVING TASK ORDER NO. 3 WITH M.E. SIMPSON COMPANY, INC. FOR LARGE WATER METER TESTING.**

**WHEREAS**, Article VII, Section 10 of the 1970 Illinois Constitution authorizes the City to contract with individuals, associations, and corporations in any manner not prohibited by law or ordinance; and

**WHEREAS**, on December 16, 2024, the City Council approved Resolution R-206-24, which authorized the City to enter into a master contract ("**Master Contract**") with M.E. Simpson Company, Inc. ("**Consultant**") for the performance of professional engineering services for the City as such services are needed over time; and

**WHEREAS**, the City desires to procure professional engineering services for large water meter testing and in-depth analysis of the City metering and billing system to identify water loss ("**Engineering Services**"); and

**WHEREAS**, Consultant submitted a proposal to perform the Engineering Services in the amount of \$91,000; and

**WHEREAS**, the City has sufficient funds in the Water Fund for the procurement of the Engineering Services from Consultant; and

**WHEREAS**, the City desires to enter into Task Order No. 3 under the Master Contract for the procurement of the Engineering Services from Consultant in the total not-to-exceed amount of \$91,000 ("**Task Order No. 3**"); and

**WHEREAS**, the City Council has determined that it is in the best interest of the City to enter into Task Order No. 3 with Consultant;

**NOW, THEREFORE, BE IT RESOLVED** by the City Council of the City of Des Plaines, Cook County, Illinois, in the exercise of its home rule powers, as follows:

**SECTION 1: RECITALS.** The foregoing recitals are incorporated into, and made a part of, this Resolution as findings of the City Council.

**SECTION 2: APPROVAL OF TASK ORDER NO. 3.** The City Council hereby approves Task Order No. 3 in substantially the form attached to this Resolution as **Exhibit A**, and in a final form to be approved by the General Counsel.

**SECTION 3: AUTHORIZATION TO EXECUTE TASK ORDER NO. 3.** The City Council hereby authorizes and directs the City Manager and the City Clerk to execute and seal, on

behalf of the City, final Task Order No. 3 only after receipt by the City Clerk of at least one executed copy of final Task Order No. 3 from Consultant; provided, however, that if the City Clerk does not receive one executed copy of final Task Order No. 3 from Consultant within 60 days after the date of adoption of this Resolution, then this authority to execute and seal final Task Order No. 3 shall, at the option of the City Council, be null and void.

**SECTION 4: EFFECTIVE DATE.** This Resolution shall be in full force and effect from and after its passage and approval according to law.

**PASSED** this \_\_\_ day of \_\_\_\_\_, 2026.

**APPROVED** this \_\_\_ day of \_\_\_\_\_, 2026.

**VOTE:** AYES \_\_\_\_\_ NAYS \_\_\_\_\_ ABSENT \_\_\_\_\_

\_\_\_\_\_  
**MAYOR**

ATTEST:

Approved as to form:

\_\_\_\_\_  
**CITY CLERK**

\_\_\_\_\_  
**Peter M. Friedman, General Counsel**

DP-Resolution Approving Task Order No 3 with ME Simpson for Large Meter Testing

**ATTACHMENT A**

**TASK ORDER NO. 3**

In accordance with Section 1.2 of the Master Contract dated January 1, 2025 between the City of Des Plaines (the “*City*”) and M.E. Simpson (the “*Consultant*”), the Parties agree to the following Task Order Number 3:

1. **Contracted Services:** Large Meter Testing.
2. **Project Schedule** (attach schedule if appropriate): See attached.
3. **Project Completion Date:**

All Contracted Services must be completed on or before: November 30, 2026

4. **Project Specific Pricing** (if applicable): \$91,000.
5. **Additional Changes to the Master Contract** (if applicable): N/A.

**ALL OTHER TERMS AND CONDITIONS OF THE MASTER CONTRACT REMAIN UNCHANGED.**

**[SIGNATURE PAGE FOLLOWS]**

**CITY**

**CONSULTANT**

\_\_\_\_\_  
Signature  
Director of Public Works  
And Engineering

\_\_\_\_\_  
Signature

\_\_\_\_\_, 20\_\_\_\_  
Date

\_\_\_\_\_, 20\_\_\_\_  
Date

If compensation is greater than \$5,000, the City Manager’s signature is required.

\_\_\_\_\_  
Signature  
City Manager

\_\_\_\_\_, 20\_\_\_\_  
Date

If compensation is greater than \$25,000, then the City Council must approve the Task Order in advance and the City Manager’s signature is required.

\_\_\_\_\_  
Signature  
City Manager

\_\_\_\_\_, 20\_\_\_\_  
Date



April 2, 2026

David Schilf  
Superintendent of Utility Services  
City of Des Plaines  
1111 Joseph J. Schwab Rd.  
Des Plaines, IL 60016

**RE: PROPOSAL FOR A LARGE WATER METER TESTING PROGRAM**

Dear Mr. Schilf,

M.E. Simpson Co., Inc. is delighted to present our proposal to the City of Des Plaines for a Large Water Meter Testing Program. We feel privileged to be considered for this endeavor and are confident that our team will contribute to the success of the project.

As a Professional Services Firm, our primary focus is on developing and delivering programs and services that optimize the performance of our clients' water distribution systems. Many of these programs are recognized globally as Best Management Practices (BMPs) for utilities. We take pride in providing robust solutions through the utilization of top-tier technical and professional services, leveraging state-of-the-art technology, and employing a highly skilled and well-trained staff of professionals. Our team of educated engineers and technical experts is fully dedicated to the success of this project and ready to alleviate the burden on your staff, ensuring a seamless continuation of services.

Our services have been meticulously developed and refined to cater to the specific needs of utilities. Whether it's offering comprehensive turn-key solutions or assisting in the development of in-house programs, M.E. Simpson Co., Inc. strives to fulfill one overarching goal: to instill public confidence by ensuring the safety and quality of drinking water.

We sincerely appreciate your consideration and the opportunity to introduce our large water meter testing services through this proposal. We are committed to surpassing your expectations and delivering exceptional results.

Sincerely,

A handwritten signature in black ink, appearing to read "Joe Nepras", with a stylized flourish at the end.

Joe Nepras  
Regional Manager

Joe Nepras  
Regional Manager

3406 Enterprise Avenue  
Valparaiso, IN 46383

800.255.1521 P  
888.531.2444 F

joen@mesimpson.com

## SCOPE OF SERVICES

### Large Water Meter Testing Program

At M.E. Simpson Co., Inc., we recognize that large water meters are the revenue backbone of any water utility. Their accuracy directly impacts billing equity, non-revenue water loss, and customer trust. Our Large Water Meter Testing Program is designed to help utilities verify and calibrate meters efficiently and safely, ensuring dependable measurement across their commercial and industrial base.

#### Field Scope of Service

M.E. Simpson Co., Inc. will undertake a thorough evaluation and testing of the large water meters selected by the Utility. Here's a condensed breakdown of our field scope of service:

| Item                        | Description  |
|-----------------------------|--|
| Resource Provisions         | <ul style="list-style-type: none"> <li>M.E. Simpson Co., Inc. will supply all necessary resources, including labor, materials, transportation, tools, and equipment</li> <li>A minimum of Two Persons per team will work on the meter testing project at all times</li> </ul>  |
| Safety Measures             | <ul style="list-style-type: none"> <li>Field staff will work in an orderly and safe manner, wearing readily observable identification badges</li> <li>We will adhere to the safety specifications outlined for equipment use</li> </ul>  |
| Meter Assessment            | <ul style="list-style-type: none"> <li>Assess all meters listed in the designated test group, observing water usage on site and meter readings to determine the accuracy and suitability for their intended application</li> <li>Recommendations will be made to the Utility if meters cannot be tested in place</li> </ul>  |
| Meter Testing Process       | <ul style="list-style-type: none"> <li>Meter tests scheduled during regular working hours whenever feasible</li> <li>Utilize AWWA-recommended flow rates and manufacturer specifications for testing</li> <li>Meters will be tested and calibrated to bring them within accepted accuracy limits</li> <li>If necessary, meters will be removed from their settings for off-site testing, with recommendations provided for bypassing the meter if service disruption is intolerable</li> </ul> |
| Documentation and Reporting | <ul style="list-style-type: none"> <li>Comprehensive meter logs will be maintained for all meters assessed in the current test group, with records reviewed by the Project Team for verification</li> </ul>  |

|                                 |  |
|---------------------------------|--|
|                                 | <ul style="list-style-type: none"> <li>• Photos of each meter and its setting will be taken for record-keeping</li> <li>• Daily progress reports will be submitted to the Project Manager, outlining the meters tested and recommendations made</li> </ul>   |
| Quality Control                 | <ul style="list-style-type: none"> <li>• Maintain strict adherence to testing protocols and standards, with all testing results and calibrations thoroughly documented</li> <li>• Meters requiring extensive calibrations or deemed obsolete will be brought to the attention of the Project Manager for potential change-out by the Utility</li> </ul>  |
| Utility Coordination            | <ul style="list-style-type: none"> <li>• Utility Staff are welcome to observe field procedures and equipment demonstrations</li> <li>• Advanced notice will be provided for any off-hours testing</li> <li>• All newly installed meters will be tested according to the project's flow testing protocols.</li> </ul>   |
| Final Reports and Communication | <ul style="list-style-type: none"> <li>• Removed meters will be returned to the Utility or left at the customer's site as directed by the Utility Project Manager upon completion of testing</li> <li>• All documentation and reporting, including meter testing results, calibrations, and recommendations, will be provided to the Utility within the specified timeframe</li> </ul>   |
| Equipment Used                  | <ul style="list-style-type: none"> <li>• Badger (Recordall) or Sensus (W-Series, Omni V2) Portable Large Water Meter Testers with digital resettable registers</li> <li>• Proper lengths of 2-1/2" fire hose for on-site testing</li> <li>• All tools needed to perform on-site testing (hand tools, pipe wrenches, etc.)</li> <li>• Confined Space Entry Equipment (tripod, winch, personal fall protection, calibrated gas detector)</li> <li>• All safety/traffic-related signs, cones, and barricades</li> <li>• All PPE required (safety glasses, gloves, hard hat, steel-toe boots, etc.)</li> </ul> |

## PROJECT SAFETY PLAN

M.E. Simpson Co., Inc.'s Safety Programs cover all aspects of the work performed by M.E. Simpson Co., Inc. We take great pride in our safety program, and that is evident in our EMR scores over the last five years. The safety of our employees, the utilities employees, and that of the general public is our #1 priority.

*“**Safety** is a significant part of any project. M.E. Simpson Co., Inc. consistently provides a safe work environment for its employees. **Our staff is trained in General Industry OSHA rules, Confined Space Entry & Self-Rescue, First Responder First Aid, CPR, and Traffic Control.** While in the field on your project, M.E. Simpson Co., Inc., and its employees will follow all of the necessary safety procedures to protect themselves, your staff, and the general public.”*

Our Safety Program, with all of its parts, is 140 pages in length. To be more efficient and less wasteful, we do not print copies of the safety program for RFPs. There is nothing secretive or proprietary contained within our safety program, and we are happy to share its contents. If you would like a PDF copy, please contact Terrence Williams, Vice President of Operations, at (800) 255-1521, and a copy will be sent to you via email.

***M.E. Simpson Co., Inc. uses Two-Person Teams for Safety and Quality Assurance.***

The use of a “one-person” team is dangerous. Many of the utilities' assets are located in roadways, treatment facilities, and confined spaces. For safety, M.E. Simpson Co., Inc. always deploys a two-person team.

**M.E. Simpson Co., Inc. adheres to the following:**

|  |
|--|
| The Project Manager and the Project Leader will be trained in accordance with OSHA Standard 1910 (General Industry) and have an OSHA 10-Hour or 30-Hour Card.  |
| Any activity located in a " <b>confined space</b> ", such as pit and vault installations that require entry, will be treated per the safety rules regarding Confined Space Entry, designated by the Utility, the Department of Labor, <b>and OSHA</b> . <u>All personnel are <b>trained</b></u> in Confined Space Entry & Self-Rescue. |
| We will follow all safety rules regarding <b>First Aid &amp; CPR, designated by the Utility, the Department of Labor, and OSHA</b> . <u>All personnel are <b>trained and certified</b></u> in First Aid & CPR.   |
| We will follow all <b>traffic safety rules designated by the Utility, the Department of Labor, OSHA, and the Department of Transportation</b> . <u>All personnel are <b>trained and certified</b></u> by the <b>AMERICAN TRAFFIC SAFETY SERVICES ASSOCIATION (ATSSA)</b> in Traffic Control and Safety.                                |

Current documentation of safety training and certifications can be provided for all project personnel for the Utility. These certifications are current and up-to-date for all project personnel.

## WORK TO BE PERFORMED

Meter Testing services will be performed on **200 large water meters**. Additional meters will be invoiced at a piece rate.

## PROPOSED PROJECT SCHEDULE

|                                  |  |
|----------------------------------|--|
| <b>Project Start Date:</b>       | TBD. Tentatively to start 6/1/2026.            |
| <b>Kick-Off Meeting:</b>         | TBD after the Project Start Date is finalized. |
| <b>Completion of Field-Work:</b> | Dependent on Project Start Date.               |
| <b>Final Reports:</b>            | Within 20 Business days of Project Completion. |

## INVESTMENT

A commitment to improving and maximizing the City of Des Plaines water distribution system for future generations.

M.E. Simpson Co., Inc. is pleased to present our proposal for a Large Water Meter Evaluation, Testing, and Calibration program for the City of Des Plaines. M.E. Simpson Co., Inc. will perform our large meter testing and calibration services on approximately **200** large water meters within the City of Des Plaines’s water distribution system.

[Calibration services and calibration post-testing are part of this proposal. Parts are separate services and are not part of this proposal. The prices listed below are valid through 12/31/2026.](#)

**Meter Testing Fee:**

|  | Test                 | Calibrate                 |
|--|----------------------|---------------------------|
|  | <u>TEST</u>          | <u>CALIBRATE</u>          |
| 1.5" through 2" displacement style meters                              | \$385.00 /test       | \$0.00 Replace            |
| 1.5" through 2" displacement style meters (Pulled)                     | \$455.00 /test       | \$0.00 Replace            |
| 1.5" through 6" compound and turbine style meters                      | 200 @ \$455.00 /test | \$91,000.00 \$175.00 ea.* |
| 8" through 10" compound and turbine style meters                       | \$525.00 /test       | \$0.00 \$200.00 ea.*      |
| 2" through 12" fire meters and fire-line meters                        | \$555.00 /test       | \$0.00 T&M **             |
| 1.5" through 12" water meter inspection/recommend (Not-Testable)       | \$415.00 /insp.      | \$0.00                    |
| <u>Appointment, Client MISSED/NO SHOW/CANCELLATION (Under 24 Hrs.)</u> | \$455.00 each        | \$455.00 ea.*             |
| Inspect & Clean Strainer (Optional)                                    | \$395.00 each        | \$395.00 ea.*             |
| <b>Project Total</b>   |                      | <b>\$91,000.00</b>        |

We thank you for this opportunity to acquaint you with our Large Water Meter Evaluation, Testing and Calibration services and offer this proposal. If you have further inquiries or would like to discuss our service further, do not hesitate to call us.

**IN WITNESS WHEREOF**, the parties hereto have caused this Agreement, the scope and proposal above for Large Water Meter Testing, to be executed on \_\_\_\_\_ 2026.

**Owner**

City of Des Plaines, IL

**Service Provider**

M.E. Simpson Company, Inc.

By: \_\_\_\_\_

Name: \_\_\_\_\_

Title: \_\_\_\_\_

Date: \_\_\_\_\_

By: \_\_\_\_\_



Name: Michael D. Simpson

Title: Chief Executive Officer

Date: 4/2/2026

Attest: \_\_\_\_\_

Name: \_\_\_\_\_

Title: \_\_\_\_\_

Date: \_\_\_\_\_

Attest: \_\_\_\_\_



Name: Joe Nepras

Title: Regional Manager

Date: 4/2/2026

**MINUTES OF THE REGULAR MEETING OF THE CITY COUNCIL OF THE CITY OF DES PLAINES, ILLINOIS HELD IN THE ELEANOR ROHRBACH MEMORIAL COUNCIL CHAMBERS, DES PLAINES CIVIC CENTER, MONDAY, APRIL 20, 2026**

**CALL TO ORDER**

The regular meeting of the City Council of the City of Des Plaines, Illinois, was called to order by Mayor Goczkowski at 6:00 PM in the Eleanor Rohrbach Memorial Council Chambers, Des Plaines Civic Center on Monday, April 20, 2026.

**ROLL CALL**

Roll call indicated the following Aldermen present: Chlebek, Moylan, Oskerka, Sayad, Merlin, Walsten, Smith, and Charewicz. A quorum was present.

**CLOSED SESSION**

Moved by Sayad, seconded by Merlin to adjourn to Closed Session for Probable & Imminent Litigation, Pending Litigation, Acquisition of Property and Personnel. Upon roll call, the vote was:

AYES: 8 - Chlebek, Moylan, Oskerka, Sayad,  
Merlin, Walsten, Smith, Charewicz

NAYS: 0 - None

ABSENT: 0 - None

Motion declared carried

**RECONVENED**

Moved by Sayad, seconded by Oskerka, the City Council meeting was reconvened at 7:04 p.m. Upon roll call the following members were present:

PRESENT: 8 - Chlebek, Moylan, Oskerka, Sayad,  
Merlin, Walsten, Smith, Charewicz

ABSENT: 0 - None

Motion declared carried

**PRAYER AND PLEDGE**

The prayer and the Pledge of Allegiance to the Flag of the United States of America were offered by Mayor Goczkowski.

**PROCLAMATION**

City Clerk Bronakowski read a proclamation recognizing Armenian Genocide Remembrance Day.

**PUBLIC COMMENT**

Kenneth Killips, resident of the 3<sup>rd</sup> ward, shared an experience with the Des Plaines Police Department while he was panhandling on River Road and requested to connect with city staff regarding the interaction.

KT Peterson thanked the City Council for participating in the sustainability survey and encouraged the City to hire a sustainability coordinator. In addition, residents were encouraged to attend a movie showing at Trinity Lutheran Church on April 23<sup>rd</sup>.

The Go Green Selection Committee presented the inaugural Go Green Sustainability Award to Neena Volupe.

John Wayne Speckman, a Des Plaines resident, shared concern about rainfall and expressed a desire to see improvements addressing river flooding issues. He proposed making amendments to support significant investment in related infrastructure projects.

Adam, resident of the 1st Ward, is new to Des Plaines and an avid cyclist who frequently bikes to work, shared his support for bike lanes. He also commented on the importance of building protected bike lanes and referenced an experience on Lee Street.

**MAYORAL  
ANNOUNCEMENTS**

Mayor Goczkowski thanked City staff for their flood response and their round-the-clock dedication in keeping the City safe during flooding. He noted it was the biggest flood in the last 43 years, and it did not impact the City significantly.

He thanked volunteers for participating in the Community Clean-Up with Clean Up, Give Back Des Plaines.

On April 22nd, the Sustainability Survey will open and encouraged residents to participate.

On April 25th, the Police Department will be hosting its DEA Take Back Day.

The Des Plaines Community Garage Sale will take place May 1-3, from 8:00 AM to sunset and he encouraged residents to participate.

**ALDERMAN  
ANNOUNCEMENTS**

Alderman Charewicz thanked Chief Anderson for attending the 8th Ward meeting. On June 2nd at 7:00 PM at the Conservatory, the guest speaker will be from the Attorney General's Office and will discuss how to prevent scams and identity theft. He encouraged residents to attend Earth Day celebrations with the Des Plaines Park District which will take place on Saturday, April 25th from 11:00 AM to 2:00 PM at the Leisure Center. In addition, the Des Plaines History Center will host a meet and greet with State Representative Cochran and Mussman on April 28th from 5:30 to 7:30 PM, with tours of the Kinder House available during the event. He also thanked City staff for their diligence in improving infrastructure and assisting with flood prevention efforts.

Alderman Oskerka shared that a new DMV has opened on Lee Street, located at 1533 Lee Street, with hours of 7:00 AM to 5:00 PM. In addition, on May 2nd at 10:00 AM, Jet City Coalition will be hosting an event at Potawatomi Park to sign up new community members to help mow laws this summer.

Alderman Sayad thanked the City for honoring the Armenian Genocide. He also thanked Brad Goodman for his emails in keeping City officials informed about the work they do.

Alderman Merlin thanked City staff for their flood prevention efforts in the City.

Alderman Walsten thanked City staff for their help with flood prevention. He also shared that there will be a 6th Ward meeting on April 30th at 7:00 PM at the Arndt Park Field House. In addition, the Des Plaines Theatre will be hosting "The Amazing Caterpillar", on April 22nd at 7:00 PM. In addition, this summer, The Des Plaines Theatre will also be showing family movies on Tuesday nights for \$1, providing an opportunity for families to get together. Regarding data centers, an informational meeting will be held on May 20th at 6:30 PM at the Des Plaines Library, to discuss the impact of data centers on communities.

Alderman Smith thanked Des Plaines City staff for their response to the flooding and encouraged residents to attend the Des Plaines Community Foundation Comedy Night fundraiser on April 22nd.

**CITY CLERK  
ANNOUNCEMENTS**

Clerk Bronakowski reflected on a successful 4th Ward meeting hosted by Alderman Sayad and thanked all the volunteers who participated in the City of Des Plaines' Clean Up, Give Back, and the Lions Club forest clean-ups.

**MANAGER'S  
REPORT**

City Manager Dorothy Wisniewski thanked the Police, Fire, and Public Works teams for their response to flooding. She noted that the river has just passed 18 feet in height and is expected to peak tonight.

**COUNSEL  
REPORT**

No announcements at this time

**CONSENT  
AGENDA**

Moved by Sayad, seconded by Oskerka, to Establish the Consent Agenda. Upon voice vote, the vote was:

AYES: 8 - Chlebek, Moylan, Oskerka, Sayad,  
Merlin, Walsten, Smith, Charewicz

NAYS: 0 - None

ABSENT: 0 - None

Motion declared carried.

Moved by Smith seconded by Merlin, to Approve the Consent Agenda. Upon voice vote, the vote was:

AYES: 8 - Chlebek, Moylan, Oskerka, Sayad,  
Merlin, Walsten, Smith, Charewicz

NAYS: 0 - None

ABSENT: 0 - None

Motion declared carried.

Resolution R-99-26, R-100-26, R-101-26, R-102-26, R-103-26, R-104-26, R-105-26, R-106-26, R-106-26, R-107-26, and R-108-26 were approved. Regular Meeting Minutes for April 6, 2026 were approved. Ordinance M-5-26, M-7-26, M-8-26, and Z-7-26 were adopted.

**APPROVING  
PURCHASE AND  
INSTALLATION OF  
US DIGITAL  
DESIGNS ALERTING  
SYSTEM**

Moved by Smith, seconded by Merlin, to approve Resolution R-99-26, Approving Purchase of US Digital Designs Alerting System Equipment and Installation from Digicom Installations, Inc. – Fire Department Equipment and Professional Services Funds. Motion declared carried as approved unanimously under Consent Agenda.

**Resolution  
R-99-26**

**APPROVING  
PURCHASE OF  
OPERATIONAL  
KNIVES FROM  
MICROTECH  
KNIVES**

Moved by Smith, seconded by Merlin, to approve Resolution R-100-26, Approving the Purchase of Operational Knives from Microtech Knives, Inc. in an Amount Not-to-Exceed \$28,465. Budgeted Funds – Foreign Fire Insurance Board/Equipment. Motion declared carried as approved unanimously under Consent Agenda.

**Resolution  
R-100-26**

**APPROVING  
PURCHASE OF  
FIREFIGHTER PPE  
AND SERVICES  
FROM DINGES FIRE  
EQUIPMENT**

Moved by Smith, seconded by Merlin, to approve Resolution R-101-26, Approving the Purchase of Firefighter Personal Protective Equipment and Services from Dinges Fire Equipment in an Amount Not-to-Exceed \$185,970.18. Budgeted Funds – Fire Department/Emergency Services/Equipment. Motion declared carried as approved unanimously under Consent Agenda.

**Resolution  
R-101-26**

**APPROVING T.O.  
CHRISTOPHER B.  
BURKE ENG. FOR  
DEVON AVE WATER  
MAIN  
IMPROVEMENTS**

Moved by Smith, seconded by Merlin, to approve Resolution R-102-26, Approving Task Order No. 3 with Christopher B. Burke Engineering, Rosemont, Illinois for Devon Avenue Water Main Improvements in the Amount of \$57,100.00. Budgeted Funds: Capital Projects. Motion declared carried as approved unanimously under Consent Agenda.

**Resolution  
R-102-26**

**APPROVING T.O.  
CHRISTOPHER B.  
BURKE ENG. FOR  
DEVON AVE  
TRAFFIC SIGNAL  
DESIGN**

Moved by Smith, seconded by Merlin, to approve Resolution R-103-26, Approving Task Order No. 4 with Christopher B. Burke Engineering, Rosemont, Illinois for Devon Avenue Traffic Signal Design in the Amount of \$39,500.00. Budgeted Funds: Capital Project. Motion declared carried as approved unanimously under Consent Agenda.

**Resolution  
R-103-26**

**APPROVING T.O.  
WITH FGM  
ARCHITECTS FOR  
CONSTRUCTION  
ADMINISTRATION  
SERVICES**

Moved by Smith, seconded by Merlin, to approve Resolution R-104-26, Approving Task Order No. 2 with FGM Architects Inc., Oak Brook, Illinois, in the Not-to-Exceed Amount of \$199,500 plus \$500 for Reimbursable Expenses for Professional Construction Administration Services. Budgeted Funds: Facilities Replacement Fund. Motion declared carried as approved unanimously under Consent Agenda.

**Resolution  
R-104-26**

**APPROVING  
REPAIR OF POLICE  
SQUAD #55 BY  
AUTOKRAFTERS**

Moved by Smith, seconded by Merlin, to approve Resolution R-105-26, Approving, in the Best Interest of the City, the Repair of Police Department Squad #55 in the Amount of \$27,871.61 plus a Contingency in the Amount of \$1,500 for a Total Amount of \$29,371.61 by AutoKrafters of Des Plaines, Des Plaines, Illinois. Source of Funding: Risk Management Funds. Motion declared carried as approved unanimously under Consent Agenda.

**Resolution  
R-105-26**

**APPROVING T.O.  
WITH BERGER  
EXCAVATING  
CONTRACTORS**

Moved by Smith, seconded by Merlin, to approve Resolution R-106-26, Approving Task Order No. 13 with Berger Excavating Contractors, Wauconda, Illinois in the Amount of \$450,000.00. Source of Funding: Water Fund. Motion declared carried as approved unanimously under Consent Agenda.

**Resolution  
R-106-26**

**AWARDING BID  
FOR HOWARD  
WATER TANK  
PAINTING TO ERA-  
VALDIVIA  
CONTRACTORS**

Moved by Smith, seconded by Merlin, to approve Resolution R-107-26, Awarding the Bid for Howard Water Tank Painting to Era-Valdivia Contractors, Inc., Chicago, Illinois in the Amount of \$1,877,180.00. Source of Funding: Capital Improvement Projects. Motion declared carried as approved unanimously under Consent Agenda.

**Resolution  
R-107-26**

**APPROVING  
LICENSE  
AGREEMENT WITH  
EZEE FIBER TEXAS**

Moved by Smith, seconded by Merlin, to approve Resolution R-108-26, Approving a License Agreement Between the City and Ezee Fiber Texas, LLC. Motion declared carried as approved unanimously under Consent Agenda.

**Resolution  
R-108-26**

**APPROVE MINUTES**

Moved by Smith, seconded by Merlin, to approve the Regular Session Minutes of the City Council meeting of April 6, 2026, as published. Motion declared carried as approved unanimously under Consent Agenda

**SECOND READING –  
ORDINANCE M-5-26**

Moved by Smith, seconded by Merlin, to approve Ordinance M-5-26, Approving the purchase of a John Deere 160 P Excavator through Sourcewell Contract# 011723-JDC, from West Side Tractor Sales Company, Naperville, Illinois, in the Amount of \$288,984.97. Budgeted Funds – Equipment Replacement. Motion declared carried as approved unanimously under Consent Agenda

**SECOND READING –  
ORDINANCE M-7-26**

Moved by Smith, seconded by Merlin, to approve Ordinance M-7-26, Approving a New Class “A” Liquor License (Tavern Seats 250 or Less - On-Site Consumption Only) for White Hill Hospitality LLC d/b/a Fairfield Inn Chicago O’Hare at 2350 Mannheim Road. Motion declared carried as approved unanimously under Consent Agenda

**SECOND READING –  
ORDINANCE M-8-26**

Moved by Smith, seconded by Merlin, to approve Ordinance M-8-26, Approving a New Class “A” Liquor License (Tavern Seats 250 or Less - On-Site Consumption Only) for Los Azares Mexican Grill, LLC at 1290 Miner Street. Motion declared carried as approved unanimously under Consent Agenda

**SECOND READING –  
ORDINANCE Z-7-26**

Moved by Smith, seconded by Merlin, to approve Ordinance Z-7-26, Approving Text Amendments to the City Code, Title 12, Zoning Regarding Regulations for Off-Street Parking, Accessory Uses Related to EV Readiness and Drive Through Facility Operation and Layout Design Regulations. Motion declared carried as approved unanimously under Consent Agenda.

**NEW BUSINESS**

**FINANCE & ADMINISTRATION** – Alderman Sayad, Chair

**WARRANT  
REGISTER**

Alderman Sayad presented the Warrant Register.

**Resolution  
R-110-26**

Moved by Sayad, seconded by Oskerka to Approve the Warrant Register of April 20, 2026, in the Amount of \$5,399,336.44 and Approve Resolution R-110-26. Upon roll call, the vote was:

AYES: 8 - Chlebek, Moylan, Oskerka, Sayad,  
Merlin, Walsten, Smith, Charewicz

NAYS: 0 - None

ABSENT: 0 - None

Motion declared carried.

**COMMUNITY DEVELOPMENT** – Alderman Moylan, Chair

**APPROVING 6B  
INCENTIVE FOR  
ELSE II LLC & MID-  
STATES**

Community and Economic Development Director Jeff Rogers reviewed a memorandum dated April 13, 2026.

The applicant, ESLE II LLC and Mid-States Recycling, Inc., is seeking the City’s support

**RECYCLING AT 1777  
BUSSE HWY**

**Resolution  
R-111-26**

for a Cook County Class 6b Real Estate Tax Incentive for the property located at 1777 Busse Highway. The applicant owns and operates Mid-States Recycling, Inc. at the adjacent property at 1841 Busse Highway, where the company has been in business since 1999. Mid-States Recycling specializes in the processing and smelting of precious metals. The request would apply only to the new construction where additional investment is proposed.

The proposed project includes the expansion of the existing facility at 1841 Busse Highway onto the neighboring vacant 0.69-acre lot at 1777 Busse Highway, through the construction of a new 15,000-square-foot addition. The expansion will include approximately 12,500 square feet of processing space and 2,500 square feet of office space. In addition to the 22 full-time employees currently working at 1841 Busse Highway, the applicant anticipates adding five new full-time employees as a result of the project.

The total project investment is estimated at \$4,380,000, or approximately \$146 per square foot, meeting the City’s minimum investment threshold for consideration of a Class 6b tax incentive. Upon completion, the property is projected to have an estimated market value of \$2,000,000 and generate approximately \$918,031 in property tax revenue over the life of the incentive. If the property were to remain vacant, it is estimated to generate approximately \$81,228 in property tax revenue over the same 12-year period.

As proposed, the applicant would save approximately \$1,081,029 in property taxes if the Class 6b incentive is approved.

Alderman Moylan shared his support of this initiative.

Moved by Chlebek, seconded by Oskerka to Approve Resolution R-111-26, CONSIDERATION OF RESOLUTION SUPPORTING COOK COUNTY CLASS 6B INCENTIVE FOR ELSE II LLC & MID-STATES RECYCLING AT 1777 BUSSE HWY. Upon roll call, the vote was

- AYES: 8 - Chlebek, Moylan, Oskerka, Sayad,  
Merlin, Walsten, Smith, Charewicz
- NAYS: 0 - None
- ABSENT: 0 - None

Motion declared carried.

**DESIGNATING 1645  
BIRCHWOOD AVE  
AS BLIGHTED AND  
APPROVING 7A TAX  
INCENTIVE FOR  
BIRCHWOOD  
VENTURE LLC**

**Resolution  
R-117-26**

Community and Economic Development Director Jeff Rogers reviewed a memorandum dated April 13, 2026.

The subject property is comprised of approximately 1.08 acres and is improved with a 30,000-square-foot vacant commercial office building. The applicant proposes a substantial rehabilitation of the existing building, including the elimination of a split-level office and replacement of that space with a new commercial truck service center, along with other site improvements.

The applicant has furnished a report titled “Blight Factors and Physical Condition Assessment,” prepared by Elliott & Associates and dated April 2, 2026, regarding the condition of the subject property and its improvements. The report notes findings consistent with the requirements of the Illinois Tax Increment Allocation Redevelopment Act and the Commercial Renewal and Redevelopment Areas Act, as necessary evidence to support a determination that the area is blighted.

**Resolution  
R-118-26**

The property was previously designated as blighted by the City via Resolution R-20-16 prior to occupancy by a previous tenant. Although the prior tenant’s total investment in the property was sufficient to qualify for a 7a classification before their occupancy, that

investment, along with deferred maintenance since that time, has not been sufficient to eliminate the current blighted conditions.

Birchwood Venture LLC is requesting the City’s designation of the property as a blighted area in need of substantial rehabilitation, along with support and consent for a Class 7a incentive. The applicant proposes to purchase the property and invest approximately \$550,000 in new physical improvements, as reflected in the building permit value. This exceeds the City’s minimum investment requirement for approval of a Class 7a incentive under City Council policy.

Alderman Walsten supports this initiative.

Moved by Walsten, seconded by Sayad to Approve Resolution R-117-26, CONSIDERATION OF RESOLUTION DESIGNATING 1645 BIRCHWOOD AVE AS BLIGHTED AREA. Upon voice roll, the vote was

AYES: 8 - Chlebek, Moylan, Oskerka, Sayad,  
Merlin, Walsten, Smith, Charewicz

NAYS: 0 - None

ABSENT: 0 - None

Motion declared carried.

Moved by Walsten, seconded by Oskerka to Approve Resolution R-118-26, CONSIDERATION OF RESOLUTION APPROVING COOK COUNTY CLASS 7A TAX INCENTIVE FOR BIRCHWOOD VENTURE LLC. Upon voice roll, the vote was:

AYES: 8 - Chlebek, Moylan, Oskerka, Sayad,  
Merlin, Walsten, Smith, Charewicz

NAYS: 0 - None

ABSENT: 0 - None

Motion declared carried.

**COMMUNITY SERVICES**– Alderman Smith, Chair

Community and Police Social Worker, Angelika Danek reviewed a memorandum dated April 20, 2026.

The 2026 Social Service Funding notification, application, and timeline were made available on the City’s website on January 30, 2026. Applications were due February 27, 2026.

HS contacted agencies that received funding in 2025, those that inquired about the program throughout the year, and those that applied for funding in prior years but did not request funds the previous year.

The City received a total request for social service funding in the amount of \$365,380 from 40 agencies. All agencies have expressed gratitude for the City’s program and emphasized how valuable local support is in leveraging funding from public and private sources, which strengthens their service capabilities for residents.

Mayor Goczkowski shared his support for this program to help service the residents.

Moved by Smith, seconded by Merlin to Approve Resolution R-113-26, CONSIDERATION OF A RESOLUTION AWARDDING 40 GRANT RECIPIENTS FOR 2026 SOCIAL SERVICE PROGRAM FUNDING IN A TOTAL AMOUNT NOT TO EXCEED \$275,000. Upon roll call, the vote was

**AWARDING 40  
SOCIAL SERVICE  
GRANTS FOR 2026  
FUNDING**

**Resolution  
R-113-26**

AYES: 8 - Chlebek, Moylan, Oskerka, Sayad,  
 Merlin, Walsten, Smith, Charewicz  
 NAYS: 0 - None  
 ABSENT: 0 - None  
 Motion declared carried.

**ENGINEERING** – Alderman Chlebek, Chair

**ADOPTING 2026  
 ACTIVE  
 TRANSPORTATION  
 PLAN**

**Resolution  
 R-112-26**

Assistant Director of Engineering, Becka Shipp reviewed a memorandum dated April 9, 2026.

In 2011, the City of Des Plaines adopted its first Active Transportation Plan, affirming a commitment to improving safety, comfort, and accessibility for all modes of travel. Since that time, the City has advanced numerous recommendations from the 2011 Plan and incorporated its priorities of safety, connectivity, and accessibility into other major planning efforts.

The 2026 Des Plaines Active Transportation Plan builds upon this progress. The updated plan refreshes the goals outlined in 2011, incorporates changes in planning practices, infrastructure, and community needs, reflects evolving travel patterns, and addresses current safety concerns. It also expands the envisioned network and outlines clear strategies and priorities for future implementation. This updated plan will guide the City’s continued efforts to create a safer and more connected environment for people walking, biking, and rolling throughout Des Plaines

Mayor Goczkowski shared his support for the Active Transportation Plan.

Colin Tyson, with Bike/Walk Des Plaines, shared his support of the plan; however, he would like to see some larger projects take place.

Moved by Chlebek, seconded by Sayad to Approve Resolution R-112-26, CONSIDERATION OF THE ADOPTION OF THE 2026 ACTIVE TRANSPORTATION PLAN. Upon roll call, the vote was

AYES: 8 - Chlebek, Moylan, Oskerka, Sayad,  
 Merlin, Walsten, Smith, Charewicz  
 NAYS: 0 - None  
 ABSENT: 0 - None  
 Motion declared carried.

Alderman Walsten thanked the Director of Communications Brad Goodman for all of his help during the last week of heavy rain.

**ADJOURNMENT**

Moved by Sayad, seconded by Merlin, to adjourn the meeting. Upon voice vote, motion declared carried. The meeting adjourned at 8:00PM.

\_\_\_\_\_  
Dominik Bronakowski – CITY CLERK

APPROVED BY ME THIS 4<sup>th</sup>  
DAY OF May, 2026

\_\_\_\_\_  
Andrew Goczkowski, MAYOR



**MEDIA SERVICES**

1420 Miner Street  
Des Plaines, IL 60016  
P: 847.391.6122  
desplainesil.gov

**MEMORANDUM**

Date: April 28, 2026  
To: Mayor and Members of the City Council  
From: Brad Goodman, Director of Communications   
Subject: Resolution Authorizing Funding for Rights to Screen Motion Pictures at the Des Plaines Theatre

---

**Issue:** Attached for City Council consideration is a resolution authorizing the City of Des Plaines to purchase the rights to screen motion pictures at the Des Plaines Theatre in an amount not to exceed \$10,000.

**Analysis:** City staff met with Ron Onesti, operator of the Des Plaines Theatre through Onesti DPT, to discuss offering a classic family film series at the theatre. The series would begin this spring and run on Tuesday evenings through the fall. Admission would be set at \$1 per ticket.

**Recommendation:** I recommend that the City Council authorize staff to purchase motion picture screening rights in an amount not to exceed \$10,000.

**Attachments:**  
Resolution R-127-26

**CITY OF DES PLAINES**

**RESOLUTION R - 127 - 26**

**A RESOLUTION AUTHORIZING THE PURCHASE OF MOTION PICTURE SCREENING RIGHTS FOR THE DES PLAINES THEATRE CLASSIC FAMILY FILM SERIES.**

**WHEREAS**, Article VII, Section 10 of the 1970 Illinois Constitution authorizes the City to contract with individuals, associations and corporations, in any manner not prohibited by law or ordinance; and

**WHEREAS**, the Des Plaines Theatre proposes to screen various motion pictures as part of a classic family film series ("*Film Series*"); and

**WHEREAS**, the City desires to purchase the screening rights for the Film Series ("*Screening Rights*"); and

**WHEREAS**, the City Council has determined that it is in the best interest of the City to authorize the City to purchase the Screening Rights for the Film Series in the not to exceed amount of \$10,000.00;

**NOW, THEREFORE, BE IT RESOLVED** by the City Council of the City of Des Plaines, Cook County, Illinois, in the exercise of its home rule powers, as follows:

**SECTION 1: RECITALS.** The foregoing recitals are incorporated into, and made a part of, this Resolution as findings of the City Council.

**SECTION 2: APPROVAL AND AUTHORIZATION TO PURCHASE SCREENING RIGHTS.** The City Manager is authorized to purchase the Screening Rights for the Film Series in an amount not to exceed \$10,000.00.

**SECTION 3: EFFECTIVE DATE.** This Resolution shall be in full force and effect from and after its passage and approval according to law.

***[SIGNATURE PAGE FOLLOW]***

**PASSED** this \_\_\_ day of \_\_\_\_\_, 2026.

**APPROVED** this \_\_\_ day of \_\_\_\_\_, 2026.

**VOTE:** AYES \_\_\_\_\_ NAYS \_\_\_\_\_ ABSENT \_\_\_\_\_

---

**MAYOR**

ATTEST:

Approved as to form:

---

CITY CLERK

---

Peter M. Friedman, City Attorney



**PUBLIC WORKS AND  
ENGINEERING DEPARTMENT**

1111 Joseph J. Schwab Road  
Des Plaines, IL 60016  
P: 847.391.5464  
desplainesil.gov

**MEMORANDUM**

Date: April 23, 2026  
To: Dorothy Wisniewski, City Manager  
From: Timothy Watkins, Director of Public Works & Engineering *TW*  
Subject: I-490 – Touhy Avenue Reconstruction

---

**Issue:** Members of the City Council have requested additional information on the I-490 and Touhy Avenue Reconstruction Project.

**Analysis:** This project impacts multiple jurisdictions and is led by Cook County and the Illinois Tollway. Aaron Lebowitz, Associate Director of Construction for the Cook County Department of Transportation and Highways, is here this evening to provide additional information and answer any questions regarding the project.

**Conclusion:** This memo is for informational purposes only.



**FINANCE DEPARTMENT**

1420 Miner Street  
Des Plaines, IL 60016  
P: 847.391.5300  
desplainesil.gov

**MEMORANDUM**

Date: April 22, 2026  
To: Dorothy Wisniewski, City Manager  
From: Agnes Podbial, Director of Finance  
Subject: Resolution R-125-26, May 4, 2026, Warrant Register

**Recommendation:** I recommend that the City Council approve the May 4, 2026, Warrant Register Resolution R-125-26.

Warrant Register.....\$3,963,686.85

**Estimated General Fund Balance**  
Balance as of 03/31/2026: \$19,692,987  
*Please use caution when evaluating this number as revenues fluctuate dramatically from month to month due to delays in receiving sales tax revenue from the State and 1<sup>st</sup> & 2<sup>nd</sup> installments of property tax revenue.*

**CITY OF DES PLAINES**

**RESOLUTION**

**R-125-26**

**Be it resolved by the City Council of the City of Des Plaines that the following bills are due and payable and that the Mayor and City Clerk be and are hereby authorized to make payment for same.**

**May 4, 2026**

# City of Des Plaines

## Warrant Register 05/04/2026

| Line #                                   | Account | Vendor                            | Invoice                                 | Invoice Description | Amount                                   |                  |
|--|---------|-----------------------------------|---|---------------------|--|------------------|
| <b>Fund: 100 - General Fund</b>          |         |                                   |   |                     |  |                  |
| <b>Department: 00 - Non Departmental</b> |         |                                   |   |                     |  |                  |
| 1  | 4210    | Personal Property Replacement Tax | 4999 Des Plaines Public Library         | 1st Qtr 2026        | Q1 2026 PPRT Allocation                  | 71,025.49        |
| 2  | 4630    | Resident Ambulance Fees           | 9469 Millhiser, Leanore M               | 25-E1003366         | Medical Reimbursement for DOS 06/06/2025 | 70.50            |
| 3  | 4630    | Resident Ambulance Fees           | 9477 Hovde, Signe                       | 25-E1357102         | Medical Reimbursement for DOS 07/29/2025 | 114.81           |
| 4  | 4630    | Resident Ambulance Fees           | 9471 Donovan, Julie                     | 25-E1387318         | Medical Reimbursement for DOS 08/03/2025 | 746.54           |
| 5  | 4630    | Resident Ambulance Fees           | 9472 McCarty, Marian                    | 25-E1857492         | Medical Reimbursement for DOS 10/02/2025 | 275.00           |
| 6  | 4630    | Resident Ambulance Fees           | 9473 Dildy, Lori M                      | 25-E1857554         | Medical Reimbursement for DOS 10/02/2025 | 275.00           |
| 7  | 4630    | Resident Ambulance Fees           | 9475 Steinhaus, Madeline                | 25-E2732202         | Medical Reimbursement for DOS 10/28/2025 | 50.00            |
| 8  | 4630    | Resident Ambulance Fees           | 9476 Visage, Renee                      | 25-E759577          | Medical Reimbursement for DOS 04/28/2025 | 111.15           |
| 9  | 4631    | Nonresident Ambulance Fees        | 1459 Blue Cross Blue Shield of Illinois | 24-E1431814         | Medical Reimbursement for DOS 12/26/2024 | 1,373.93         |
| 10                                       | 4631    | Nonresident Ambulance Fees        | 9470 Gordon Gordon and Centracchio, LLP | 25-E1665379         | Medical Reimbursement for DOS 09/09/2025 | 25.00            |
| 11                                       | 4631    | Nonresident Ambulance Fees        | 9474 Moran TTEES, Thomas A              | 25-E2659894         | Medical Reimbursement for DOS 10/26/2025 | 250.00           |
| 12                                       | 4631    | Nonresident Ambulance Fees        | 9478 Fountain, Anne H                   | 25-E826966          | Medical Reimbursement for DOS 05/07/2025 | 145.51           |
| <b>Total 00 - Non Departmental</b>       |         |                                   |   |                     |  | <b>74,462.93</b> |

| <b>Elected Office</b>              |      |                       |                                      |          |  |          |
|------------------------------------|------|-----------------------|--------------------------------------|----------|--|----------|
| <b>Division: 110 - Legislative</b> |      |                       |                                      |          |  |          |
| 13                                 | 6000 | Professional Services | 9261 J Alexander Hunt Inc            | 29202603 | Lobbyist Services - March 2026, R-141-25 | 5,000.00 |
| 14                                 | 6000 | Professional Services | 9271 Taft Stettinius & Hollister LLP | 7062678  | Lobbyist Services - March 2026- R-140-25 | 5,000.00 |

# City of Des Plaines

## Warrant Register 05/04/2026

| Line #                         | Account | Vendor         | Invoice        | Invoice Description | Amount               |                  |
|--------------------------------|---------|----------------|----------------|---------------------|----------------------|------------------|
| 15                             | 7200    | Other Supplies | 2016 Signarama | 46188               | Engraved Name Badges | 198.00           |
| <b>Total 110 - Legislative</b> |         |                |                |                     |                      | <b>10,198.00</b> |

| <b>Division: 120 - City Clerk</b> |      |                                    |                                  |            |  |               |
|-----------------------------------|------|------------------------------------|----------------------------------|------------|--|---------------|
| 16                                | 6100 | Publication of Notices             | 1050 Journal & Topics Newspapers | 196164     | Legal Notice - 2026 Brick Paver Repairs 03/25/2026         | 97.43         |
| 17                                | 6100 | Publication of Notices             | 1050 Journal & Topics Newspapers | 196223     | Legal Notice - 2026 Asphalt Milling 04/01/2026             | 97.43         |
| 18                                | 6100 | Publication of Notices             | 1069 Paddock Publications Inc    | 373116     | Legal Notice - 2026 CIP Water Main Improvements 03/20/2026 | 40.50         |
| 19                                | 6195 | Miscellaneous Contractual Services | 1077 Shred-It USA LLC            | 8013952742 | Shredding Services for 02/27-03/27/2026                    | 93.96         |
| <b>Total 120 - City Clerk</b>     |      |                                    |                                  |            |  | <b>329.32</b> |

|                                  |  |  |  |  |  |                  |
|----------------------------------|--|--|--|--|--|------------------|
| <b>Total 10 - Elected Office</b> |  |  |  |  |  | <b>10,527.32</b> |
|----------------------------------|--|--|--|--|--|------------------|

| <b>City Administration</b>          |      |                |                |       |                      |              |
|-------------------------------------|------|----------------|----------------|-------|----------------------|--------------|
| <b>Division: 210 - City Manager</b> |      |                |                |       |                      |              |
| 20                                  | 7200 | Other Supplies | 2016 Signarama | 46188 | Engraved Name Badges | 36.00        |
| <b>Total 210 - City Manager</b>     |      |                |                |       |                      | <b>36.00</b> |

| <b>Division: 230 - Information Technology</b> |      |              |                                 |                |  |                 |
|---|------|--------------|---------------------------------|----------------|--|-----------------|
| 21  | 6300 | R&M Software | 5934 Tyler Technologies Inc     | 025-542086     | Hosted Report Management 02/01/2026-01/31/2027         | 1,500.00        |
| 22  | 6300 | R&M Software | 1370 Microsystems Inc           | 20260278       | Annual Maint of BlueLake Software 05/15/2026-5/14/2027 | 233.00          |
| 23  | 6300 | R&M Software | 5934 Tyler Technologies Inc     | CI100-00236048 | EnerGov Maintenance 01/01/2026-12/31/2026              | 3,319.62        |
| 24  | 6300 | R&M Software | 8395 Sentinel Technologies, Inc | INV60677       | Fortis-Services 03/01/2026-03/31/2026                  | 4,871.10        |
| <b>Total 230 - Information Technology</b>     |      |              |                                 |                |  | <b>9,923.72</b> |

| <b>Division: 240 - Media Services</b> |      |                                   |                                  |             |   |          |
|---------------------------------------|------|-----------------------------------|----------------------------------|-------------|---|----------|
| 25                                    | 6108 | Public Relations & Communications | 8670 Proforma Albrecht & Company | 1306154     | City-Branded Ribbon for Grand Openings              | 762.19   |
| 26                                    | 6110 | Printing Services                 | 1233 Press Tech Inc              | 57302       | Box of Business Cards for City Photographer 4/10/26 | 30.00    |
| 27                                    | 8015 | Equipment                         | 1035 Dell Marketing LP           | 10869183280 | Edit Station for PT Media Services Crew             | 6,575.38 |

# City of Des Plaines

## Warrant Register 05/04/2026

| Line #                            | Account | Vendor    | Invoice                | Invoice Description | Amount                                  |       |
|-----------------------------------|---------|-----------|------------------------|---------------------|---|-------|
| 28                                | 8015    | Equipment | 1035 Dell Marketing LP | 10869183280         | Edit Station for PT Media Services Crew | 48.97 |
| <b>Total 240 - Media Services</b> |         |           |                        |                     | <b>7,416.54</b>                         |       |

| <b>Division: 250 - Human Resources</b> |      |                                    |  |            |  |        |
|--|------|------------------------------------|--|------------|--|--------|
| 29                                     | 5340 | Pre-Employment Testing             | 1267 Northwest Community Hospital            | 39396      | 2 New Hire Pre-Employment Testing 3/27-3/30/2026             | 280.00 |
| 30                                     | 5340 | Pre-Employment Testing             | 1267 Northwest Community Hospital            | 39397      | 1 New Hire Pre-Employment Testing 3/30/2026                  | 50.00  |
| 31                                     | 5340 | Pre-Employment Testing             | 8533 Justifacts Credential Verification      | 417736     | 6 Pre-Employment Background Screening Services 3/2-3/20/2026 | 359.87 |
| 32                                     | 6100 | Publication of Notices             | 1485 ILCMA - IL City/County Management Assoc | 6900       | 2 Job Postings: Maint. Op. and Water Op. 04/07-04/27/2026    | 100.00 |
| 33                                     | 6195 | Miscellaneous Contractual Services | 1077 Shred-It USA LLC                        | 8013952742 | Shredding Services for 02/27-03/27/2026                      | 93.96  |
| <b>Total 250 - Human Resources</b>     |      |                                    |  |            | <b>883.83</b>  |        |

|                                       |  |  |  |  |                  |
|---------------------------------------|--|--|--|--|------------------|
| <b>Total 20 - City Administration</b> |  |  |  |  | <b>18,260.09</b> |
|---------------------------------------|--|--|--|--|------------------|

| <b>Department: 30 - Finance</b> |      |                                    |                       |            |   |       |
|---------------------------------|------|------------------------------------|-----------------------|------------|---|-------|
| 34                              | 6195 | Miscellaneous Contractual Services | 1077 Shred-It USA LLC | 8013952742 | Shredding Services for 02/27-03/27/2026 | 93.96 |
| 35                              | 7200 | Other Supplies                     | 2016 Signarama        | 46188      | Engraved Name Badges                    | 23.50 |
| <b>Total 30 - Finance</b>       |      |                                    |                       |            | <b>117.46</b>                           |       |

| <b>Community Development</b>                           |      |                       |   |       |  |          |
|--|------|-----------------------|---|-------|--|----------|
| <b>Division: 410 - Building &amp; Code Enforcement</b> |      |                       |   |       |  |          |
| 36   | 6000 | Professional Services | 6315 B&F Construction Code Services Inc | 22248 | March 2026 Inspection Services         | 4,362.30 |
| 37   | 6000 | Professional Services | 6315 B&F Construction Code Services Inc | 71341 | Plan Review 03/25/26 Project # 1136949 | 350.00   |
| 38   | 6000 | Professional Services | 6315 B&F Construction Code Services Inc | 71369 | Plan Review 03/30/26 Project # 1136886 | 2,695.00 |
| 39   | 6000 | Professional Services | 6315 B&F Construction Code Services Inc | 71384 | Plan Review 03/31/26 Project # 1136979 | 350.00   |
| 40   | 6000 | Professional Services | 6315 B&F Construction Code Services Inc | 71397 | Plan Review 03/31/26 Project # 1137030 | 350.00   |
| 41   | 6000 | Professional Services | 6315 B&F Construction Code Services Inc | 71419 | Plan Review 04/02/26 Project # 1137045 | 350.00   |
| 42   | 6000 | Professional Services | 6315 B&F Construction Code Services Inc | 71461 | Plan Review 04/08/26 Project # 1137010 | 1,102.50 |
| 43   | 6000 | Professional Services | 6315 B&F Construction Code Services Inc | 71467 | Plan Review 04/09/26 Project # 1137043 | 210.00   |

# City of Des Plaines

## Warrant Register 05/04/2026

| Line #   | Account |                       | Vendor                                   | Invoice | Invoice Description           | Amount           |
|--|---------|-----------------------|--|---------|-------------------------------|------------------|
| 44   | 6000    | Professional Services | 8629 Health Inspection Professionals Inc | 931     | March 2026 Health Inspections | 13,690.00        |
| <b>Total 410 - Building &amp; Code Enforcement</b> |         |                       |  |         |                               | <b>23,459.80</b> |

| <b>Division: 420 - Planning &amp; Zoning</b> |      |                       |                            |                  |  |                 |
|--|------|-----------------------|----------------------------|------------------|--|-----------------|
| 45   | 6000 | Professional Services | 9366 Antero Group LLC, The | CoD-2501.00-2603 | Housing Studies - Consulting Service Through 04/2026 | 1,952.50        |
| <b>Total 420 - Planning &amp; Zoning</b>     |      |                       |                            |                  |  | <b>1,952.50</b> |

| <b>Division: 430 - Economic Development</b> |      |                       |   |            |   |               |
|---|------|-----------------------|---|------------|---|---------------|
| 46  | 6000 | Professional Services | 5215 CoStar Realty Information Inc              | 123864979  | April 2026 Available Property Database  | 550.52        |
| 47  | 6000 | Professional Services | 1532 Des Plaines Chamber of Commerce & Industry | 8503695906 | December 2025 Business Retention Survey | 400.00        |
| <b>Total 430 - Economic Development</b>     |      |                       |   |            |   | <b>950.52</b> |

|   |  |  |  |  |  |                  |
|---|--|--|--|--|--|------------------|
| <b>Total 40 - Community Development</b> |  |  |  |  |  | <b>26,362.82</b> |
|---|--|--|--|--|--|------------------|

| <b>Public Works &amp; Engineering</b> |      |                       |                                      |         |   |                 |
|---------------------------------------|------|-----------------------|--------------------------------------|---------|---|-----------------|
| <b>Division: 100 - Administration</b> |      |                       |                                      |         |   |                 |
| 48                                    | 6000 | Professional Services | 9387 Blue Strike Environmental, Inc. | DES_004 | Sustainability Plan Update - 03/01-03/31/2026, R-218-25 | 9,633.45        |
| <b>Total 100 - Administration</b>     |      |                       |                                      |         |   | <b>9,633.45</b> |

| <b>Division: 530 - Street Maintenance</b> |      |                                    |  |                  |  |           |
|---|------|------------------------------------|--|------------------|--|-----------|
| 49  | 6115 | Licensing/Titles                   | 4761 Hampe, Daniel                     | Reimb 03/20/2026 | CDL Reimbursement - Arborist - Exp 06/22/2030            | 30.00     |
| 50  | 6170 | Tree Maintenance                   | 6555 Landscape Concepts Management Inc | 72519            | Parkway Tree Maintenance - Zone 5 - 03/31/2026, R-153-23 | 26,516.00 |
| 51  | 6170 | Tree Maintenance                   | 6555 Landscape Concepts Management Inc | 72520            | Stump Removals & Restorations - 03/31/2026, R-153-23     | 9,005.25  |
| 52  | 6170 | Tree Maintenance                   | 6555 Landscape Concepts Management Inc | 72521            | Tree Removals - 02/09/2026, R-153-23                     | 22,622.00 |
| 53  | 6170 | Tree Maintenance                   | 6555 Landscape Concepts Management Inc | 72522            | Stump Removals & Restorations - 03/11/2026, R-153-23     | 3,737.25  |
| 54  | 6195 | Miscellaneous Contractual Services | 6121 Shred First Inc                   | 137458           | Paper Shredding - 03/28/2026                             | 900.00    |
| 55  | 6195 | Miscellaneous Contractual Services | 8826 Chem-Wise Pest Management         | 1435575          | Pest Control - Joseph, Fox, Pratt - 03/03/2026           | 500.00    |

# City of Des Plaines

## Warrant Register 05/04/2026

| Line #                                | Account | Vendor                             | Invoice                      | Invoice Description | Amount  |          |
|---------------------------------------|---------|------------------------------------|------------------------------|---------------------|---|----------|
| 56                                    | 6195    | Miscellaneous Contractual Services | 1197 Snow Systems            | 25-069522           | Sidewalk Snow Removal - 12/29/2025, R-120-25                | 4,595.00 |
| 57                                    | 6195    | Miscellaneous Contractual Services | 1197 Snow Systems            | 25-069775           | Sidewalk Snow Removal - 01/30-01/31/2026, R-120-25          | 9,295.00 |
| 58                                    | 6325    | R&M Street Lights                  | 1044 H&H Electric Co         | 47629               | Locate - Oakton Tower - 11/11/2025, R-41-25                 | 549.98   |
| 59                                    | 6325    | R&M Street Lights                  | 1044 H&H Electric Co         | 47710               | Streetlight Repair - Lee/Ellinwood - 11/26/2025, R-41-25    | 813.72   |
| 60                                    | 6325    | R&M Street Lights                  | 1044 H&H Electric Co         | 47711               | Streetlight Repair - Rivers Casino - 11/29/2025, R-41-25    | 5,927.24 |
| 61                                    | 6325    | R&M Street Lights                  | 1044 H&H Electric Co         | 48491               | Streetlight Repair - Metro Square - 03/10/2026, R-41-25     | 1,882.38 |
| 62                                    | 6325    | R&M Street Lights                  | 1044 H&H Electric Co         | 48492               | Streetlight Repair - Oakton/ Lee - 03/11/2026, R-41-25      | 556.02   |
| 63                                    | 6325    | R&M Street Lights                  | 1044 H&H Electric Co         | 48493               | Locate - Hawthorne - 03/13/2026, R-41-25                    | 549.54   |
| 64                                    | 7020    | Supplies - Safety                  | 1520 Russo Power Equipment   | SPI21502385         | 2 Bayonet Adapters  | 23.98    |
| 65                                    | 7050    | Supplies - Streetscape             | 1347 Lurvey Landscape Supply | T1-10610492         | 3.0 Cu Yds Topsoil - Restorations - 04/07/2026              | 105.00   |
| 66                                    | 7050    | Supplies - Streetscape             | 1347 Lurvey Landscape Supply | T1-10610690         | 3.0 Cu Yds Topsoil & Grass Seed - Restorations - 04/08/2026 | 170.00   |
| 67                                    | 7055    | Supplies - Street R&M              | 1732 High Star Traffic       | 19702               | Sign Posts & Anchors  | 3,442.50 |
| 68                                    | 7200    | Other Supplies                     | 1233 Press Tech Inc          | 57231               | 10,000 Window Envelopes - Tree Planting                     | 1,440.00 |
| 69                                    | 7200    | Other Supplies                     | 1233 Press Tech Inc          | 57232               | 2,500 Return Envelopes - Tree Planting                      | 450.00   |
| 70                                    | 7300    | Uniforms                           | 2067 Cutler Workwear         | PS-INV059807        | Work Boots - Quartermasters                                 | 197.95   |
| <b>Total 530 - Street Maintenance</b> |         |                                    |                              |                     | <b>93,308.81</b>  |          |

| Division: 535 - Facilities & Grounds Maintenance |      |                                    |                                |         |  |       |
|--|------|------------------------------------|--------------------------------|---------|--|-------|
| 71   | 6195 | Miscellaneous Contractual Services | 8826 Chem-Wise Pest Management | 1440660 | Pest Control - 656 Pearson - 03/31/2026    | 70.00 |
| 72   | 6195 | Miscellaneous Contractual Services | 8826 Chem-Wise Pest Management | 1442166 | Pest Control - City Hall - 04/06/2026      | 60.00 |
| 73   | 6195 | Miscellaneous Contractual Services | 8826 Chem-Wise Pest Management | 1442170 | Pest Control - Police Station - 04/06/2026 | 60.00 |

# City of Des Plaines

## Warrant Register 05/04/2026

| Line # | Account | Vendor                             | Invoice                             | Invoice Description | Amount  |          |
|--------|---------|------------------------------------|-------------------------------------|---------------------|---|----------|
| 74     | 6195    | Miscellaneous Contractual Services | 8826 Chem-Wise Pest Management      | 1442200             | Pest Control - Metra Train Station - 04/06/2026           | 50.00    |
| 75     | 6195    | Miscellaneous Contractual Services | 7146 JOS Services Inc               | 19923               | TO#5 Plumbing Repair - 04/02/2026, R-204-24               | 1,885.00 |
| 76     | 6195    | Miscellaneous Contractual Services | 1029 Cintas Corporation             | 4255836248          | Mat Service - Police Station - 01/09/2026                 | 97.71    |
| 77     | 6195    | Miscellaneous Contractual Services | 1029 Cintas Corporation             | 4264842709          | Mat Service - Police Station - 04/03/2026                 | 97.71    |
| 78     | 6195    | Miscellaneous Contractual Services | 1029 Cintas Corporation             | 4264842728          | Mat Service - Metra Train Station - 04/03/2026            | 41.83    |
| 79     | 6195    | Miscellaneous Contractual Services | 9023 Granite Telecommunications LLC | 741563445           | Elevator Communications - Fire Department - 04/01/2026    | 231.00   |
| 80     | 6195    | Miscellaneous Contractual Services | 9023 Granite Telecommunications LLC | 741589231           | Elevator Communications - Civic Deck - 04/01/2026         | 302.66   |
| 81     | 6195    | Miscellaneous Contractual Services | 9023 Granite Telecommunications LLC | 741607420           | Elevator Communications - City Hall - 04/01/2026          | 304.46   |
| 82     | 6195    | Miscellaneous Contractual Services | 5214 State Industrial Products      | 904040253           | Wastewater Program - City Hall - 12/21/2025               | 362.25   |
| 83     | 6195    | Miscellaneous Contractual Services | 5214 State Industrial Products      | 904071898           | Wastewater Program - City Hall - 01/21/2026               | 362.25   |
| 84     | 6195    | Miscellaneous Contractual Services | 5214 State Industrial Products      | 904078248           | Primezyme - City Hall & Police Station - 01/28/2026       | 382.95   |
| 85     | 6315    | R&M Buildings & Structures         | 1237 Pro-Line Door Systems Inc      | 101466              | Overhead Door Repair - PW - 03/25/2026                    | 4,476.00 |
| 86     | 6315    | R&M Buildings & Structures         | 1135 Colley Elevator Co             | 297582              | Elevator Inspection - Theater - 04/01/2026                | 196.00   |
| 87     | 6315    | R&M Buildings & Structures         | 7599 JF Ahern Company               | 807654              | Special Hazards Inspection - City Hall - 03/01/2026       | 579.00   |
| 88     | 6315    | R&M Buildings & Structures         | 7599 JF Ahern Company               | 809316              | Pre-Engineered Inspection - Theater - 03/01/2026          | 663.00   |
| 89     | 6315    | R&M Buildings & Structures         | 7599 JF Ahern Company               | 809318              | Pre-Engineered Inspection - Fire Station #63 - 03/01/2026 | 663.00   |
| 90     | 6315    | R&M Buildings & Structures         | 7599 JF Ahern Company               | 810406              | Pre-Engineered Inspection - Fire Station #61 - 03/01/2026 | 663.00   |

# City of Des Plaines

## Warrant Register 05/04/2026

| Line # | Account | Vendor                      | Invoice                              | Invoice Description | Amount   |           |
|--------|---------|-----------------------------|--------------------------------------|---------------------|--|-----------|
| 91     | 6315    | R&M Buildings & Structures  | 4583 Argon Electric Company, Inc     | 9972                | TO #9 Security Camera Sys - Fire Station #61 -04/02/2026, R-1-25 | 17,540.00 |
| 92     | 6315    | R&M Buildings & Structures  | 8772 Helm Service                    | CHI145185P          | Recontrol Ventilation - Gun Range - 03/31/2026                   | 15,471.00 |
| 93     | 6315    | R&M Buildings & Structures  | 2350 Anderson Elevator Co            | INV-115925-J7D8     | Elevator Inspections - CH, PD, Metro, Library - April 2026       | 509.00    |
| 94     | 6315    | R&M Buildings & Structures  | 2350 Anderson Elevator Co            | INV-115925-J7D8     | Elevator Inspections - CH, PD, Metro, Library - April 2026       | 184.00    |
| 95     | 6315    | R&M Buildings & Structures  | 7706 Lakeshore Recycling Systems LLC | LR6725416           | Dumpster Roll-Off - City Hall - 03/23/2026                       | 450.85    |
| 96     | 7025    | Supplies - Custodial        | 1029 Cintas Corporation              | 4264842859          | Cleaners, Paper Towels, Soap, Mat, Scrubs, Etc. - PW             | 387.56    |
| 97     | 7030    | Supplies - Tools & Hardware | 1047 Home Depot Credit Svcs          | 4604216             | Paint Sprayer, Paint, Fuel                                       | 733.68    |
| 98     | 7030    | Supplies - Tools & Hardware | 1047 Home Depot Credit Svcs          | 4622105             | Wet Dry Vac, Filters, Dust Bags Shoe Kit                         | 227.91    |
| 99     | 7030    | Supplies - Tools & Hardware | 1047 Home Depot Credit Svcs          | 6510872             | Floor Scraper & Rotary Hammer                                    | 708.00    |
| 100    | 7030    | Supplies - Tools & Hardware | 1047 Home Depot Credit Svcs          | 8523951             | Saw Blades, Drill Bits, Blade Kit, Bit Set                       | 226.85    |
| 101    | 7030    | Supplies - Tools & Hardware | 1047 Home Depot Credit Svcs          | 8600280             | 2 Tape Measures  | 63.94     |
| 102    | 7045    | Supplies - Building R&M     | 9436 Mount Prospect Paint, Inc.      | 00165476            | 5 Gals Paint - Fire Station #63                                  | 233.95    |
| 103    | 7045    | Supplies - Building R&M     | 9436 Mount Prospect Paint, Inc.      | 00165478            | 8 Gals Primer - City Hall  | 990.52    |
| 104    | 7045    | Supplies - Building R&M     | 9436 Mount Prospect Paint, Inc.      | 00165504            | Frames & Convert Poles - City Hall                               | 95.02     |
| 105    | 7045    | Supplies - Building R&M     | 9436 Mount Prospect Paint, Inc.      | 00165514            | 5 Gals Paint, Racx Guard, Racx Fine Finish - City Hall           | 449.68    |
| 106    | 7045    | Supplies - Building R&M     | 9436 Mount Prospect Paint, Inc.      | 00165553            | 11 Gals Paint - City Hall  | 1,559.59  |
| 107    | 7045    | Supplies - Building R&M     | 1237 Pro-Line Door Systems Inc       | 101494              | Overhead Door Repair - PW - 03/27/2026                           | 1,959.20  |
| 108    | 7045    | Supplies - Building R&M     | 7807 L&W Supply Corporation          | 1016629921-001      | 160 Studs - City Hall  | 1,732.00  |
| 109    | 7045    | Supplies - Building R&M     | 7807 L&W Supply Corporation          | 1017488526-001      | Ceiling Grid - City Hall   | 347.76    |
| 110    | 7045    | Supplies - Building R&M     | 9248 Ferguson Enterprises LLC        | 1347580             | Plumbing Supplies - City Hall                                    | 2,534.50  |
| 111    | 7045    | Supplies - Building R&M     | 1057 Menard Incorporated             | 21252               | Struts, Pipes, Flange, Spring Nuts, Beam Clamp, Etc. - FS#61     | 470.62    |
| 112    | 7045    | Supplies - Building R&M     | 1057 Menard Incorporated             | 65426               | Ceiling Fan, Electrical Tape, Foil Tape - City Hall              | 36.45     |

# City of Des Plaines

## Warrant Register 05/04/2026

| Line # | Account | Vendor                  | Invoice                  | Invoice Description | Amount   |          |
|--------|---------|-------------------------|--------------------------|---------------------|--|----------|
| 113    | 7045    | Supplies - Building R&M | 1057 Menard Incorporated | 65434               | Funnel Set, Wall Protector, Drop Cloth - Police Station      | 17.35    |
| 114    | 7045    | Supplies - Building R&M | 1057 Menard Incorporated | 65438               | Paint Rollers, Edger Tray, Paint Trays - Metra Train Station | 45.50    |
| 115    | 7045    | Supplies - Building R&M | 1057 Menard Incorporated | 65447               | 1 Gallon Paint - Metra Train Station                         | 40.89    |
| 116    | 7045    | Supplies - Building R&M | 1057 Menard Incorporated | 65453               | Paint Bucket, Brushes, Cup, Tray - Police Station            | 36.32    |
| 117    | 7045    | Supplies - Building R&M | 1057 Menard Incorporated | 67458               | Metal Tracks, Metal Studs, Screws - City Hall                | 78.28    |
| 118    | 7045    | Supplies - Building R&M | 1057 Menard Incorporated | 67519               | Angled Sponges - City Hall                                   | 31.96    |
| 119    | 7045    | Supplies - Building R&M | 1057 Menard Incorporated | 67520               | Data Material - Fire Station #61                             | 129.96   |
| 120    | 7045    | Supplies - Building R&M | 1057 Menard Incorporated | 67524               | Returned Data Materials - Station 61                         | (129.96) |
| 121    | 7045    | Supplies - Building R&M | 1057 Menard Incorporated | 67526               | Metal Corner Beads - City Hall                               | 19.76    |
| 122    | 7045    | Supplies - Building R&M | 1057 Menard Incorporated | 67533               | Pails, Lids, Rollers, Buckets, Paint Brushes - City Hall     | 243.10   |
| 123    | 7045    | Supplies - Building R&M | 1057 Menard Incorporated | 67537               | Rubber Washers & Sealant - City Hall                         | 18.64    |
| 124    | 7045    | Supplies - Building R&M | 1057 Menard Incorporated | 67538               | 2 Floor Scrapers - City Hall                                 | 51.98    |
| 125    | 7045    | Supplies - Building R&M | 1057 Menard Incorporated | 67625               | Seam Sealer, Brush Set, Grout Sponge - Civic Deck            | 27.71    |
| 126    | 7045    | Supplies - Building R&M | 1057 Menard Incorporated | 67832               | Light Bulbs, Electrical Connectors, Ceiling Light - PW       | 63.95    |
| 127    | 7045    | Supplies - Building R&M | 1057 Menard Incorporated | 67853               | J-Beads & Corner Beads - City Hall                           | 34.75    |
| 128    | 7045    | Supplies - Building R&M | 1057 Menard Incorporated | 67891               | Threadlocker, Couplings, Flange, Pipes, Washers - FS#61      | 655.24   |
| 129    | 7045    | Supplies - Building R&M | 1057 Menard Incorporated | 67892               | Square Washers - Fire Station #61                            | 77.50    |
| 130    | 7045    | Supplies - Building R&M | 1057 Menard Incorporated | 67896               | Locknuts, Cover Blanks, Nipples, Screws - Fire Station #63   | 31.35    |
| 131    | 7045    | Supplies - Building R&M | 1057 Menard Incorporated | 67919               | Bleach - Metra Train Station                                 | 43.08    |
| 132    | 7045    | Supplies - Building R&M | 1057 Menard Incorporated | 67947               | Pail, Sand, Organizers - City Hall                           | 22.75    |
| 133    | 7045    | Supplies - Building R&M | 1057 Menard Incorporated | 68004               | Strut, Pipes, Washers, Nipples - Fire Station #61            | 131.74   |

# City of Des Plaines

## Warrant Register 05/04/2026

| Line # | Account | Vendor                  | Invoice                        | Invoice Description | Amount   |          |
|--------|---------|-------------------------|--------------------------------|---------------------|--|----------|
| 134    | 7045    | Supplies - Building R&M | 1057 Menard Incorporated       | 68010               | Spray Primer - City Hall                                       | 19.96    |
| 135    | 7045    | Supplies - Building R&M | 1057 Menard Incorporated       | 68014               | Washers - Fire Station #61                                     | 56.31    |
| 136    | 7045    | Supplies - Building R&M | 8244 Des Plaines Ace Hardware  | 8375                | Knob Key Safe - PW   | 44.99    |
| 137    | 7045    | Supplies - Building R&M | 8244 Des Plaines Ace Hardware  | 8396                | Fasteners - PW   | 5.08     |
| 138    | 7045    | Supplies - Building R&M | 8244 Des Plaines Ace Hardware  | 8463                | 4 Tubes Caulk - PW   | 17.96    |
| 139    | 7045    | Supplies - Building R&M | 8244 Des Plaines Ace Hardware  | 8495                | Fasteners - PW   | 2.00     |
| 140    | 7045    | Supplies - Building R&M | 8244 Des Plaines Ace Hardware  | 8496                | Impact Power Bit Set - PW                                      | 12.59    |
| 141    | 7045    | Supplies - Building R&M | 1047 Home Depot Credit Svcs    | 8510652             | Loop Chain, Hex Nuts, Eyebolts, Flip Toggle - Fire Station #63 | 48.78    |
| 142    | 7045    | Supplies - Building R&M | 5214 State Industrial Products | 904005865           | Restroom Program - Police Station - 11/20/2025                 | 328.92   |
| 143    | 7045    | Supplies - Building R&M | 5214 State Industrial Products | 904040092           | Restroom Program - Police Station - 01/04/2026                 | 328.92   |
| 144    | 7045    | Supplies - Building R&M | 1047 Home Depot Credit Svcs    | 9073294             | Lattice Moulding & Drydex - Fire Station #63                   | 10.56    |
| 145    | 7045    | Supplies - Building R&M | 8244 Des Plaines Ace Hardware  | 9243                | AAA & AA Batteries - Metra Train Station                       | 39.58    |
| 146    | 7045    | Supplies - Building R&M | 1047 Home Depot Credit Svcs    | 9600043             | Floor Protection, Seam Tape, Edge Tape - City Hall             | 225.28   |
| 147    | 7045    | Supplies - Building R&M | 1043 WW Grainger Inc           | 9872416020          | Electronic Module - Metra Train Station                        | 155.93   |
| 148    | 7045    | Supplies - Building R&M | 1043 WW Grainger Inc           | 9874498935          | Hot/Cold Cartridge - Fire Station #63                          | 212.70   |
| 149    | 7045    | Supplies - Building R&M | 2507 Idlewood Electric Supply  | INV277005           | Electrical Supplies - Fire Station #63                         | 472.24   |
| 150    | 7045    | Supplies - Building R&M | 2507 Idlewood Electric Supply  | INV290764           | Lighting Supplies - City Hall                                  | 1,217.88 |
| 151    | 7045    | Supplies - Building R&M | 2507 Idlewood Electric Supply  | INV290800           | Lighting Supplies - City Hall                                  | 947.24   |
| 152    | 7045    | Supplies - Building R&M | 8366 Connexion                 | S2139249.001        | Electrical Supplies - City Hall                                | 868.84   |
| 153    | 7045    | Supplies - Building R&M | 8366 Connexion                 | S2139249.003        | Electrical Supplies - City Hall                                | 973.54   |
| 154    | 7045    | Supplies - Building R&M | 8366 Connexion                 | S2139249.009        | Electrical Supplies - City Hall                                | 245.62   |
| 155    | 7045    | Supplies - Building R&M | 8366 Connexion                 | S2139249.012        | Electrical Supplies - City Hall                                | 349.27   |
| 156    | 7045    | Supplies - Building R&M | 8366 Connexion                 | S2139249.020        | Electric Supplies - City Hall                                  | 15.43    |

# City of Des Plaines

## Warrant Register 05/04/2026

| Line #  | Account | Vendor                  | Invoice                  | Invoice Description | Amount                                      |            |
|---|---------|-------------------------|--------------------------|---------------------|---|------------|
| 157   | 7045    | Supplies - Building R&M | 8366 Connexion           | S2139249.021        | Returned Electric Supplies - City Hall      | (1,308.85) |
| 158   | 7045    | Supplies - Building R&M | 8366 Connexion           | S2139249.022        | Electrical Supplies - City Hall             | 3,025.91   |
| 159   | 7045    | Supplies - Building R&M | 8366 Connexion           | S2139249.023        | Electrical Supplies - City Hall             | 544.00     |
| 160   | 7045    | Supplies - Building R&M | 8366 Connexion           | S2139249.024        | Electrical Supplies - City Hall             | 824.35     |
| 161   | 7045    | Supplies - Building R&M | 8366 Connexion           | S2139249.025        | Electrical Supplies - City Hall             | 1,193.94   |
| 162   | 7045    | Supplies - Building R&M | 8366 Connexion           | S2139249.027        | Electrical Supplies - City Hall             | 678.95     |
| 163   | 7045    | Supplies - Building R&M | 8366 Connexion           | S2139249.028        | Returned Electrical Supplies - City Hall    | (1,138.22) |
| 164   | 7045    | Supplies - Building R&M | 8366 Connexion           | S2139249.029        | Breaker - City Hall                         | 390.00     |
| 165   | 7045    | Supplies - Building R&M | 8366 Connexion           | S2139249.030        | Remodel Parts - City Hall                   | 428.45     |
| 166   | 7045    | Supplies - Building R&M | 8366 Connexion           | S2156467.002        | Camera Install Materials - Fire Station #61 | 3,729.16   |
| 167   | 7200    | Other Supplies          | 1057 Menard Incorporated | 67770               | 20 Cases Bottled Water - City Hall          | 73.08      |
| <b>Total 535 - Facilities &amp; Grounds Maintenance</b> |         |                         |                          |                     | <b>75,172.14</b>                            |            |

| <b>Division: 540 - Vehicle Maintenance</b> |      |                                    |                                   |               |  |        |
|--|------|------------------------------------|-----------------------------------|---------------|--|--------|
| 168  | 6115 | Licensing/Titles                   | 8938 James Drive Safety Lane LLC  | 1172          | Safety Lane Inspections - PW 5100 - 04/08/2026 | 41.00  |
| 169  | 6135 | Rentals                            | 1029 Cintas Corporation           | 4260024963    | Mechanic's Uniform Rental - 02/18/2026         | 263.21 |
| 170  | 6135 | Rentals                            | 1029 Cintas Corporation           | 4264538733    | Mechanic's Uniform Rental - 04/01/2026         | 263.21 |
| 171  | 6135 | Rentals                            | 1029 Cintas Corporation           | 4265434729    | Mechanic's Uniform Rental - 04/08/2026         | 263.21 |
| 172  | 6195 | Miscellaneous Contractual Services | 8854 Ford Motor Co.               | INV44545536   | Ford Telematics - PW 5161 - 03/31/2026         | 40.00  |
| 173  | 6310 | R&M Vehicles                       | 1071 Pomp's Tire Service Inc      | 280182459     | 5 Painted Wheels - FD Stock                    | 255.00 |
| 174  | 7035 | Supplies - Equipment R&M           | 8481 Linde Gas & Equipment Inc    | 55951977      | Propane Purchase - 04/04/2026                  | 279.87 |
| 175  | 7035 | Supplies - Equipment R&M           | 9262 NAPA Auto Parts              | 951386        | 6 Filters - PW 5005                            | 170.36 |
| 176  | 7035 | Supplies - Equipment R&M           | 5035 Northwest Trucks Inc         | X101252109:02 | 10 Terminals - PW 5134                         | 10.50  |
| 177  | 7040 | Supplies - Vehicle R&M             | 1078 Acme Truck Brake & Supply Co | 01_518361     | Air Bag - FD 7609                              | 819.00 |

# City of Des Plaines

## Warrant Register 05/04/2026

| Line # | Account | Vendor                 | Invoice                           | Invoice Description | Amount  |           |
|--------|---------|------------------------|-----------------------------------|---------------------|---|-----------|
| 178    | 7040    | Supplies - Vehicle R&M | 1078 Acme Truck Brake & Supply Co | 01_524562           | Shock Absorbers & Disc Pad Set - FD 7707            | 445.73    |
| 179    | 7040    | Supplies - Vehicle R&M | 1535 Wipeco Inc                   | 0147907-IN          | Shop Rags   | 442.88    |
| 180    | 7040    | Supplies - Vehicle R&M | 1018 Anderson Lock Company LTD    | 1193676             | 6 Keys Cut - PD 6930                                | 58.62     |
| 181    | 7040    | Supplies - Vehicle R&M | 1071 Pomp's Tire Service Inc      | 280182339           | 4 Drive Tires - Fire 7708                           | 1,720.44  |
| 182    | 7040    | Supplies - Vehicle R&M | 1501 Foster Coach Sales Inc       | 30782               | Door Parts & Lighting - FD 7707                     | 1,439.59  |
| 183    | 7040    | Supplies - Vehicle R&M | 1643 Golf Mill Ford               | 611488P             | Valve Cover & Gasket - FD 7512                      | 173.02    |
| 184    | 7040    | Supplies - Vehicle R&M | 1643 Golf Mill Ford               | 611514P             | Coolant Hose - PD 6094                              | 117.78    |
| 185    | 7040    | Supplies - Vehicle R&M | 1643 Golf Mill Ford               | 611636P             | Waste Gate Acuator - FD 7512                        | 225.34    |
| 186    | 7040    | Supplies - Vehicle R&M | 2137 McMaster-Carr Supply Company | 62675586            | Bolt Kit - FD 7608                                  | 9.71      |
| 187    | 7040    | Supplies - Vehicle R&M | 8244 Des Plaines Ace Hardware     | 8398                | Paint Containers & Lids                             | 16.12     |
| 188    | 7040    | Supplies - Vehicle R&M | 8244 Des Plaines Ace Hardware     | 8603                | Slot Angle - PW Stock                               | 24.29     |
| 189    | 7040    | Supplies - Vehicle R&M | 8244 Des Plaines Ace Hardware     | 9208                | Spray Paint - PW 5165                               | 6.29      |
| 190    | 7040    | Supplies - Vehicle R&M | 9262 NAPA Auto Parts              | 951036              | Brake Pads, Lube, Brake Rotors - PW 5114            | 400.85    |
| 191    | 7040    | Supplies - Vehicle R&M | 9262 NAPA Auto Parts              | 951170              | Cabin & Air Filters - FD 7707                       | 188.67    |
| 192    | 7040    | Supplies - Vehicle R&M | 9262 NAPA Auto Parts              | 951229              | 10 Wiper Blades - FD Stock                          | 108.10    |
| 193    | 7040    | Supplies - Vehicle R&M | 9262 NAPA Auto Parts              | 951231              | 10 Wiper Blades - FD Stock                          | 112.70    |
| 194    | 7040    | Supplies - Vehicle R&M | 9262 NAPA Auto Parts              | 951244              | Diesel Exhaust Fluid - PW Stock                     | 269.80    |
| 195    | 7040    | Supplies - Vehicle R&M | 9262 NAPA Auto Parts              | 951247              | Blend Door Actuators - PD 6078                      | 45.63     |
| 196    | 7040    | Supplies - Vehicle R&M | 9262 NAPA Auto Parts              | 951302              | Oil Filter & Oil - PW 9059                          | 17.90     |
| 197    | 7040    | Supplies - Vehicle R&M | 8104 MacQueen Emergency Group     | P37897              | 2 Radiator Hoses - FD 7609                          | 58.77     |
| 198    | 7040    | Supplies - Vehicle R&M | 8104 MacQueen Emergency Group     | P38402              | Shock Absorbers & Ball Joint Kits - FD 7608         | 3,390.84  |
| 199    | 7040    | Supplies - Vehicle R&M | 8104 MacQueen Emergency Group     | P38490              | Cab Bushings & Pins - FD 7608                       | 457.89    |
| 200    | 7040    | Supplies - Vehicle R&M | 5035 Northwest Trucks Inc         | X101251887:02       | V-Clamp - PW Stock                                  | 154.50    |
| 201    | 7120    | Gasoline               | 1014 Al Warren Oil Company Inc    | W1835356            | 5,019 Gals Unleaded Gasoline - 04/13/2026, R-217-25 | 13,534.07 |

# City of Des Plaines

## Warrant Register 05/04/2026

| Line #                                 | Account                  | Vendor                         | Invoice    | Invoice Description                               | Amount           |
|--|--------------------------|--------------------------------|------------|---|------------------|
| 202                                    | 7130 Diesel              | 1014 Al Warren Oil Company Inc | W1835355   | 2,001 Gals Bio Diesel Fuel - 04/13/2026, R-217-25 | 5,696.10         |
| 203                                    | 7320 Equipment < \$5,000 | 1043 WW Grainger Inc           | 9864514501 | Cutting & Grinding Oil - PW Shop                  | 232.60           |
| <b>Total 540 - Vehicle Maintenance</b> |                          |                                |            |   | <b>31,753.59</b> |

|  |                   |
|--|-------------------|
| <b>Total 50 - Public Works &amp; Engineering</b> | <b>209,867.99</b> |
|--|-------------------|

| Police Department                     |                      |   |        |  |               |
|---------------------------------------|----------------------|---|--------|--|---------------|
| <b>Division: 100 - Administration</b> |                      |   |        |  |               |
| 204                                   | 5310 Membership Dues | 1506 International Assoc of Chiefs of Police Inc (IACP) | 457808 | Membership Dues 1/1-12/31/2026 (Chief) | 220.00        |
| <b>Total 100 - Administration</b>     |                      |   |        |  | <b>220.00</b> |

|   |                     |                               |         |                                     |                 |
|---|---------------------|-------------------------------|---------|-------------------------------------|-----------------|
| <b>Division: 610 - Uniformed Patrol</b> |                     |                               |         |                                     |                 |
| 205                                     | 7200 Other Supplies | 2509 Lynn Peavey Co           | 425986  | 11 Drug Test Kits                   | 344.70          |
| 206                                     | 7300 Uniforms       | 1244 Ray O'Herron Company Inc | 2431507 | Uniforms for New Officer 8/19/2025  | 70.79           |
| 207                                     | 7300 Uniforms       | 1244 Ray O'Herron Company Inc | 2445021 | Uniforms for New Officer 8/19/2025  | 186.84          |
| 208                                     | 7300 Uniforms       | 1244 Ray O'Herron Company Inc | 2453204 | Uniforms for New Officer 12/29/2025 | 381.21          |
| 209                                     | 7300 Uniforms       | 1244 Ray O'Herron Company Inc | 2457372 | Uniforms for New Officer 1/9/2026   | 1,082.73        |
| <b>Total 610 - Uniformed Patrol</b>     |                     |                               |         |                                     | <b>2,066.27</b> |

|   |   |                                |            |                                       |               |
|---|---|--------------------------------|------------|---------------------------------------|---------------|
| <b>Division: 620 - Criminal Investigation</b> |   |                                |            |                                       |               |
| 210   | 6195 Miscellaneous Contractual Services | 1572 LexisNexis Risk Solutions | 1100290084 | Investigations Database 3/1-3/31/2026 | 155.40        |
| 211   | 6195 Miscellaneous Contractual Services | 1683 Thomson Reuters           | 853417519  | Investigations Database 3/1-3/31/2026 | 453.49        |
| <b>Total 620 - Criminal Investigation</b>     |   |                                |            |                                       | <b>608.89</b> |

|   |                            |                                    |          |  |          |
|---|----------------------------|------------------------------------|----------|--|----------|
| <b>Division: 630 - Support Services</b> |                            |                                    |          |  |          |
| 212                                     | 6000 Professional Services | 5975 Aero Removals Trisons Inc     | 112565   | Removal and Transport of 3 Deceased March 2026 | 1,305.00 |
| 213                                     | 6110 Printing Services     | 1142 Copyset Printing Company      | 66850    | 1,000 Vehicle Tow NCR 3/26/2026                | 198.00   |
| 214                                     | 6110 Printing Services     | 1142 Copyset Printing Company      | 67000    | 1,000 Arrest Jackets 3/13/2026                 | 885.00   |
| 215                                     | 6110 Printing Services     | 1142 Copyset Printing Company      | 67013    | 80 Daily Activity Forms 3/26/2026              | 400.00   |
| 216                                     | 6185 Animal Control        | 4125 Golf Rose Boarding & Grooming | 04012026 | Stray Animal Impoundment March 2026 (7)        | 460.00   |

# City of Des Plaines

## Warrant Register 05/04/2026

| Line #                              | Account | Vendor                             | Invoice                         | Invoice Description | Amount   |           |
|-------------------------------------|---------|------------------------------------|---------------------------------|---------------------|--|-----------|
| 217                                 | 6190    | Tow/Storage/Abandoned Fees         | 9367 Belmont Kolmar Towing Inc. | 46597               | Towing Services March 2026                                     | 40.00     |
| 218                                 | 6195    | Miscellaneous Contractual Services | 7736 Velan Solutions LLC        | 1149                | Police Peer Support Network System Renewal 5/16/2026-5/15/2027 | 2,184.00  |
| 219                                 | 6195    | Miscellaneous Contractual Services | 8566 Andy Frain Services Inc    | 392409              | 2026 Crossing Guard Services 3/1-3/31/2026 R-2-25              | 33,724.08 |
| 220                                 | 6195    | Miscellaneous Contractual Services | 1077 Shred-It USA LLC           | 8013952742          | Shredding Services for 02/27-03/27/2026                        | 469.77    |
| 221                                 | 6300    | R&M Software                       | 8806 Flock Group Inc            | INV-90765           | Flock Safety Program (Year 2 of 2) Jan-Dec 2026, R-159-25      | 32,500.00 |
| <b>Total 630 - Support Services</b> |         |                                    |                                 |                     | <b>72,165.85</b>   |           |

|                                     |                  |
|-------------------------------------|------------------|
| <b>Total 60 - Police Department</b> | <b>75,061.01</b> |
|-------------------------------------|------------------|

| Fire Department                    |      |                            |                                      |             |  |          |
|------------------------------------|------|----------------------------|--------------------------------------|-------------|--|----------|
| Division: 710 - Emergency Services |      |                            |                                      |             |  |          |
| 222                                | 5325 | Training                   | 1252 NIPSTA                          | 102209560   | Heavy Vehicle Rescue Class 10/12-10/19/26 -5 PM's                | 8,750.00 |
| 223                                | 5325 | Training                   | 1252 NIPSTA                          | 102218436   | Heavy Vehicle Rescue, Instructor I - 10/12-11/13/2026 - 2 PM's   | 2,650.00 |
| 224                                | 5325 | Training                   | 1252 NIPSTA                          | 102771833   | Basic Operations FF Academy 4/6-6/5/2026 - 1 Paramedic           | 5,950.00 |
| 225                                | 5325 | Training                   | 1252 NIPSTA                          | 103232160   | Passenger Vehicle Rescue - 06/09-06/12/2026 - 1 Paramedic        | 1,435.00 |
| 226                                | 5325 | Training                   | 1252 NIPSTA                          | 103280838   | Fire Apparatus Engineer - 09/14 - 09/18/2026 - 1 Paramedic       | 1,050.00 |
| 227                                | 5325 | Training                   | 2219 Jones & Bartlett Learning LLC   | 1295146     | 1 Rope Rescue Book, 1 Vehicle Rescue Book, Desk Reference 4/8/26 | 802.67   |
| 228                                | 5345 | Post-Employment Testing    | 1267 Northwest Community Hospital    | 39238       | 1 New Hire, 2 Fire Annual Physicals 03/02-03/24/2026             | 724.00   |
| 229                                | 6035 | Dispatch Services          | 5973 Emergency Twenty Four Inc       | 45430       | Elevator Alarm Dispatch Fees - March 2026                        | 1,153.00 |
| 230                                | 6305 | R&M Equipment              | 1147 Zoll Medical Corp               | 91004722    | Annual Dues for Ambulance Monitor - 02/01/2026-01/31/2027        | 340.00   |
| 231                                | 6315 | R&M Buildings & Structures | 1525 Hastings Air-Energy Control Inc | PS-I0017764 | Service Call @ Station 63 - 03/25/2026                           | 2,045.00 |

# City of Des Plaines

## Warrant Register 05/04/2026

| Line #   | Account | Vendor                  | Invoice                        | Invoice Description | Amount  |           |
|--|---------|-------------------------|--------------------------------|---------------------|---|-----------|
| 232  | 7000    | Office Supplies         | 1644 Warehouse Direct Inc      | 6122868-0           | 3 Cases Copy Paper - Station 61                         | 161.28    |
| 233  | 7000    | Office Supplies         | 1644 Warehouse Direct Inc      | 6127395-0           | 5 Boxes Batteries                                       | 77.88     |
| 234  | 7025    | Supplies - Custodial    | 1043 WW Grainger Inc           | 9865069943          | 6 Brooms  | 156.54    |
| 235  | 7045    | Supplies - Building R&M | 8244 Des Plaines Ace Hardware  | 9234                | 8 Cans Spray Paint, 8 Rolls Tape - Station 63           | 124.58    |
| 236  | 7200    | Other Supplies          | 1571 Welding Industrial Supply | R03515951           | 16 Cylinders - March 2026                               | 200.77    |
| 237  | 7300    | Uniforms                | 3212 On Time Embroidery Inc    | 151916              | 2 Polos - Paramedic                                     | 113.00    |
| 238  | 7300    | Uniforms                | 3212 On Time Embroidery Inc    | 151923              | 3 Polos, 1 Pair of Pants - Paramedic                    | 241.00    |
| 239  | 7300    | Uniforms                | 3212 On Time Embroidery Inc    | 152012              | 1 Shirt - Battalion Chief                               | 84.00     |
| 240  | 7300    | Uniforms                | 3212 On Time Embroidery Inc    | 152054              | 1 Pair of Pants - Paramedic                             | 79.00     |
| 241  | 7300    | Uniforms                | 3212 On Time Embroidery Inc    | 152102              | 3 Pairs of Pants - Paramedic                            | 225.00    |
| 242  | 7300    | Uniforms                | 3212 On Time Embroidery Inc    | 152350              | 1 Hooded Coat, 1 Shirt - Lieutenant                     | 88.00     |
| 243  | 7300    | Uniforms                | 3212 On Time Embroidery Inc    | 152433              | 1 Pair of Boots - Lieutenant                            | 189.00    |
| 244  | 7300    | Uniforms                | 3212 On Time Embroidery Inc    | 152615              | 2 Pairs of Pants - Battalion Chief                      | 158.00    |
| 245  | 7300    | Uniforms                | 3212 On Time Embroidery Inc    | 152926              | 1 Coat - Lieutenant                                     | 159.00    |
| 246  | 7300    | Uniforms                | 3212 On Time Embroidery Inc    | 153231              | 1 Tie - Lieutenant                                      | 11.00     |
| 247  | 7300    | Uniforms                | 3212 On Time Embroidery Inc    | 153734              | 4 Shirts, 1 Pair of Shorts - Engineer                   | 135.00    |
| 248  | 7300    | Uniforms                | 3212 On Time Embroidery Inc    | 153735              | 6 Shirts, 1 Hoodie - Lieutenant                         | 163.00    |
| 249  | 7320    | Equipment < \$5,000     | 6652 Stryker Sales Corporation | 9211892147          | R-56-26 Power Pro Ambulance Stretcher                   | 37,268.68 |
| 250  | 7550    | Miscellaneous Expenses  | 1228 Pesche's Inc              | 162660              | 2 Flower Bouquets for Promotional Ceremony - 03/16/2026 | 100.00    |
| <b>Total 710 - Emergency Services</b>              |         |                         |                                |                     | <b>64,634.40</b>  |           |
| <b>Division: 730 - Emergency Management Agency</b> |         |                         |                                |                     |   |           |
| 251  | 7300    | Uniforms                | 3212 On Time Embroidery Inc    | 152440              | 3 Shirts, 1 Pair of Pants, 1 Cap - EMA                  | 179.00    |
| <b>Total 730 - Emergency Management Agency</b>     |         |                         |                                |                     | <b>179.00</b>   |           |
| <b>Total 70 - Fire Department</b>                  |         |                         |                                |                     | <b>64,813.40</b>  |           |

# City of Des Plaines

## Warrant Register 05/04/2026

| Line #   | Account | Vendor                             | Invoice                                      | Invoice Description | Amount   |            |
|--|---------|------------------------------------|--|---------------------|--|------------|
| <b>Department: 75 - Fire &amp; Police Commission</b> |         |                                    |  |                     |  |            |
| 252  | 5340    | Pre-Employment Testing             | 9218 COPS and FIRE Personnel Testing Service | 2379                | Pre-Employment Psychological Testing Services 3/19-3/24/2026     | 1,250.00   |
| 253  | 5340    | Pre-Employment Testing             | 1267 Northwest Community Hospital            | 39238               | 1 New Hire, 2 Fire Annual Physicals 03/02-03/24/2026             | 935.00     |
| 254  | 5340    | Pre-Employment Testing             | 1267 Northwest Community Hospital            | 39333               | 1 BFPC New Hire Testing 03/11/2026                               | 713.00     |
| <b>Total 75 - Fire &amp; Police Commission</b>       |         |                                    |  |                     | <b>2,898.00</b>  |            |
| <b>Department: 90 - Overhead</b>                     |         |                                    |  |                     |  |            |
| 255  | 6030    | AMB Fee Processing Services        | 9063 EMS Management & Consultants Inc        | EMS-025031          | Ambulance Collections for March 2026                             | 8,545.68   |
| <b>Total 90 - Overhead</b>                           |         |                                    |  |                     | <b>8,545.68</b>  |            |
| <b>Total 100 - General Fund</b>                      |         |                                    |  |                     | <b>490,916.70</b>  |            |
| <b>Fund: 208 - TIF #8 Oakton</b>                     |         |                                    |  |                     |  |            |
| 256  | 6195    | Miscellaneous Contractual Services | 8950 DEM Services, Inc.                      | 23480               | Abatement Services - 1032-1062 Lee - 03/06/2026, R-34-26         | 43,900.00  |
| <b>Total 208 - TIF #8 Oakton</b>                     |         |                                    |  |                     | <b>43,900.00</b>   |            |
| <b>Fund: 260 - Asset Seizure Fund</b>                |         |                                    |  |                     |  |            |
| <b>Program: 2620 - DEA</b>                           |         |                                    |  |                     |  |            |
| 257  | 7015    | Supplies - Police Range            | 9139 Eagle Point Gun/TJ Morris and Sons      | 225601              | 4 Cases of .308 Ammunition for TRT                               | 2,592.00   |
| 258  | 7320    | Equipment < \$5,000                | 5174 Tri-Tech Forensics Inc                  | 01318159            | 10 Medical Kits for Officers                                     | 792.80     |
| 259  | 8015    | Equipment                          | 1045 Havey Communications                    | 15136               | Upfit Replacement D.E.A. T.F.O Squad 3/30/2026                   | 3,930.00   |
| <b>Total 2620 - DEA</b>                              |         |                                    |  |                     | <b>7,314.80</b>  |            |
| <b>Total 260 - Asset Seizure Fund</b>                |         |                                    |  |                     | <b>7,314.80</b>  |            |
| <b>Fund: 400 - Capital Projects Fund</b>             |         |                                    |  |                     |  |            |
| 260  | 6000    | Professional Services              | 1079 AECOM Technical Services Inc            | 2001131107          | TO#2 - 2025 Professional Eng Svcs R-32-25, 2/28-3/27/26          | 16,715.25  |
| 261  | 6000    | Professional Services              | 1126 Civiltech Engineering Inc               | 57088               | Task Order #6 Active Transportation Plan R-225-23 - 2/28-3/27/26 | 1,932.00   |
| 262  | 8100    | Improvements                       | 3691 A Lamp Concrete Contractors Inc         | 2025-WM-P4          | 2025 CIP Water Main Improvements R-130-25, 3/14-4/9/26           | 230,574.37 |

# City of Des Plaines

## Warrant Register 05/04/2026

| Line #                                   | Account | Vendor       | Invoice                              | Invoice Description | Amount   |            |
|--|---------|--------------|--------------------------------------|---------------------|--|------------|
| 263                                      | 8100    | Improvements | 3691 A Lamp Concrete Contractors Inc | 2025-WM-P4          | 2025 CIP Water Main Improvements R-130-25, 3/14-4/9/26 | 200,000.00 |
| 264                                      | 8100    | Improvements | 2032 Mount Prospect, Village of      | 2026-00067001       | R-171-23 Central Rd Resurfacing DP Portion 3/26/26     | 21,333.45  |
| 265                                      | 8100    | Improvements | 1139 Cook County of Illinois         | Touhy Av GS #1      | R-173-22 Touhy Ave GS 1st Installment 11/8/25          | 64,000.00  |
| <b>Total 400 - Capital Projects Fund</b> |         |              |                                      |                     | <b>534,555.07</b>                                      |            |

| Fund: 410 - Equipment Replacement Fund |      |          |                                  |        |   |            |
|--|------|----------|----------------------------------|--------|---|------------|
| Department: 60 - Police Department     |      |          |                                  |        |   |            |
| 266                                    | 8020 | Vehicles | 1146 Currie Motors Frankfort Inc | E2318A | (6) 2026 Ford Explorers - PD - 03/26/2026, R-241-25 | 287,754.00 |
| <b>Total 60 - Police Department</b>    |      |          |                                  |        | <b>287,754.00</b>                                   |            |

|   |  |  |  |  |                   |
|---|--|--|--|--|-------------------|
| <b>Total 410 - Equipment Replacement Fund</b> |  |  |  |  | <b>287,754.00</b> |
|---|--|--|--|--|-------------------|

| Fund: 420 - IT Replacement Fund        |      |                   |                        |             |  |           |
|--|------|-------------------|------------------------|-------------|--|-----------|
| 267                                    | 8005 | Computer Hardware | 1035 Dell Marketing LP | 10869378143 | Dell Pro 32 Plus 4K USB-C Hub Monitor    | 394.95    |
| 268                                    | 8005 | Computer Hardware | 1035 Dell Marketing LP | 10869966921 | Dell Pro Plus Earbuds                    | 158.15    |
| 269                                    | 8005 | Computer Hardware | 1035 Dell Marketing LP | 10869966948 | Dell Pro Plus Active Pen                 | 27.50     |
| 270                                    | 8005 | Computer Hardware | 1035 Dell Marketing LP | 10870385505 | 10 Dell Pro Micro Plus QBM1250 - R-50-26 | 16,569.40 |
| 271                                    | 8005 | Computer Hardware | 9410 Core 4 Solutions  | 400426      | 8 Cisco C9300 Switches                   | 22,400.00 |
| <b>Total 420 - IT Replacement Fund</b> |      |                   |                        |             | <b>39,550.00</b>                         |           |

| Fund: 430 - Facilities Replacement Fund |      |                            |  |              |  |            |
|---|------|----------------------------|--|--------------|--|------------|
| 272                                     | 6000 | Professional Services      | 9405 Affordable Technology Solutions, Inc. | 1091         | Utility Project Management - Fire Station 62 - 03/29/2026  | 700.00     |
| 273                                     | 6000 | Professional Services      | 9337 Pope Design Group                     | 251787       | TO#1 Design & Engineering - 678 Lee - 01/31/2026, R-154-25 | 121,547.04 |
| 274                                     | 6000 | Professional Services      | 7661 FGM Architects Inc                    | 26-4536.01-1 | TO #1 Architectural Svcs - 1504 Miner - 02/21-03/27/2026   | 14,500.00  |
| 275                                     | 6000 | Professional Services      | 9337 Pope Design Group                     | 260326       | TO#1 Design & Engineering - 678 Lee - 03/31/2026, R-154-25 | 138,528.00 |
| 276                                     | 6315 | R&M Buildings & Structures | 8826 Chem-Wise Pest Management             | 1442189      | Pest Control - Leela Building - 04/06/2026                 | 50.00      |

# City of Des Plaines

## Warrant Register 05/04/2026

| Line #   | Account | Vendor                     | Invoice                            | Invoice Description | Amount  |          |
|--|---------|----------------------------|------------------------------------|---------------------|---|----------|
| 277  | 6315    | R&M Buildings & Structures | 7371 Gilco Scaffolding Company LLC | 22218               | Pedestrian Protection Scaffold - 678 Lee - 03/04-03/31/2026 | 1,200.00 |
| <b>Total 430 - Facilities Replacement Fund</b> |         |                            |                                    |                     | <b>276,525.04</b>   |          |

| Fund: 500 - Water/Sewer Fund  |      |                                     |  |             |  |          |
|-------------------------------|------|-------------------------------------|--|-------------|--|----------|
| Division: 550 - Water Systems |      |                                     |  |             |  |          |
| 278                           | 6040 | Waste Hauling & Debris Removal      | 5772 Berger Excavating Contractors Inc | 24002.3-03  | Aggregate Materials & Spoils Disposal - March 2026, R-191-23 | 1,156.05 |
| 279                           | 6110 | Printing Services                   | 1233 Press Tech Inc                    | 57230       | 10,000 Door Hangers - Water 04/10/2026                       | 1,225.00 |
| 280                           | 6180 | Water Sample Testing                | 1642 Suburban Laboratories, Inc        | GA6000420   | Water Sample Testing - 08/07/2025-11/25/2025                 | 1,909.00 |
| 281                           | 6180 | Water Sample Testing                | 1642 Suburban Laboratories, Inc        | GA6001521   | Water Sample Testing - 02/27/2026-03/24/2026                 | 2,258.18 |
| 282                           | 6195 | Miscellaneous Contractual Services  | 3781 Smith Ecological Systems Company  | 25434       | Chlorine System Maintenance - 03/27/2026                     | 539.97   |
| 283                           | 6195 | Miscellaneous Contractual Services  | 1467 HBK Water Meter Service Inc       | 260167      | 3 Meter Bench Tests - 04/06/2026                             | 90.00    |
| 284                           | 6195 | Miscellaneous Contractual Services  | 4022 M E Simpson Co Inc                | 46292       | Leak Detection - 545 Touhy - 03/31/2026                      | 965.00   |
| 285                           | 7030 | Supplies - Tools & Hardware         | 8244 Des Plaines Ace Hardware          | 8458        | Drill Bits   | 30.58    |
| 286                           | 7035 | Supplies - Equipment R&M            | 8481 Linde Gas & Equipment Inc         | 55951977    | Propane Purchase - 04/04/2026                                | 279.87   |
| 287                           | 7040 | Supplies - Vehicle R&M              | 1535 Wipeco Inc                        | 0147907-IN  | Shop Rags  | 265.73   |
| 288                           | 7040 | Supplies - Vehicle R&M              | 9262 NAPA Auto Parts                   | 951237      | Tail Lights - PW 9066  | 205.97   |
| 289                           | 7040 | Supplies - Vehicle R&M              | 9262 NAPA Auto Parts                   | 951301      | Air Filters & Engine Oil Filters - PW 9059                   | 40.90    |
| 290                           | 7050 | Supplies - Streetscape              | 1347 Lurvey Landscape Supply           | T1-10606950 | 2.0 Cu Yds Topsoil & 25 Lbs Grass Seed - 11/19/2025          | 132.00   |
| 291                           | 7050 | Supplies - Streetscape              | 1347 Lurvey Landscape Supply           | T1-10610338 | 3.0 Cu Yds Topsoil - Restorations - 04/06/2026               | 105.00   |
| 292                           | 7050 | Supplies - Streetscape              | 1347 Lurvey Landscape Supply           | T1-10610413 | 1.0 Cu Yd Topsoil - Restorations - 04/06/2026                | 35.00    |
| 293                           | 7070 | Supplies - Water System Maintenance | 1255 Neenah Foundry Company            | 211545      | 30 Water Manhole Lids  | 4,740.00 |
| 294                           | 7070 | Supplies - Water System Maintenance | 5772 Berger Excavating Contractors Inc | 24002.3-03  | Aggregate Materials & Spoils Disposal - March 2026, R-191-23 | 490.11   |

# City of Des Plaines

## Warrant Register 05/04/2026

| Line # | Account | Vendor                              | Invoice                                | Invoice Description | Amount   |          |
|--------|---------|-------------------------------------|--|---------------------|--|----------|
| 295    | 7070    | Supplies - Water System Maintenance | 3530 Mid-American Water                | 263263A             | Copper Corps, Curb Stops, Copper Couplings                       | 3,140.00 |
| 296    | 7070    | Supplies - Water System Maintenance | 3530 Mid-American Water                | 291070W             | Valves, Reducer, Megalugs  | 4,763.00 |
| 297    | 7070    | Supplies - Water System Maintenance | 3530 Mid-American Water                | 291071W             | Sleeves, Bends, Megalugs, Tees                                   | 4,092.00 |
| 298    | 7070    | Supplies - Water System Maintenance | 3530 Mid-American Water                | 291072W             | Valves & Megalugs  | 2,254.00 |
| 299    | 7070    | Supplies - Water System Maintenance | 3530 Mid-American Water                | 291098W             | Hydrant Tee & Manhole Lid  | 1,840.00 |
| 300    | 7070    | Supplies - Water System Maintenance | 3530 Mid-American Water                | 291107W             | Valves, Megalugs, Sleeves  | 4,782.00 |
| 301    | 7070    | Supplies - Water System Maintenance | 3530 Mid-American Water                | 291108W             | Valves, Megalugs, Tees   | 3,388.00 |
| 302    | 7070    | Supplies - Water System Maintenance | 3530 Mid-American Water                | 468424WD-1          | PVC Pipes  | 3,256.80 |
| 303    | 7070    | Supplies - Water System Maintenance | 1437 Des Plaines Material & Supply LLC | 52957               | Epoxy Saddle   | 147.53   |
| 304    | 7070    | Supplies - Water System Maintenance | 1437 Des Plaines Material & Supply LLC | 53090               | Flange Gasket  | 42.38    |
| 305    | 7070    | Supplies - Water System Maintenance | 1437 Des Plaines Material & Supply LLC | 53369               | Split Bottom, Vault, Offset Cone - Westgate/Thacker              | 2,124.00 |
| 306    | 7070    | Supplies - Water System Maintenance | 1437 Des Plaines Material & Supply LLC | 53421               | Valve Vault, Manhole Boots, Concentric Cone - Oakton/Mt Prospect | 1,515.14 |
| 307    | 7070    | Supplies - Water System Maintenance | 1047 Home Depot Credit Svcs            | 6080839             | Drill Bits, Extension, Latex Brushes                             | 346.41   |
| 308    | 7070    | Supplies - Water System Maintenance | 1057 Menard Incorporated               | 67759               | Light Bulbs & Electrical Tape - Central                          | 20.47    |
| 309    | 7070    | Supplies - Water System Maintenance | 8244 Des Plaines Ace Hardware          | 8499                | Sawsall Blades   | 38.68    |
| 310    | 7070    | Supplies - Water System Maintenance | 8244 Des Plaines Ace Hardware          | 8565                | Torch Head   | 44.08    |

# City of Des Plaines

## Warrant Register 05/04/2026

| Line # | Account | Vendor                              | Invoice                            | Invoice Description | Amount  |            |
|--------|---------|-------------------------------------|------------------------------------|---------------------|---|------------|
| 311    | 7070    | Supplies - Water System Maintenance | 8244 Des Plaines Ace Hardware      | 8612                | Hydraulic Cement                                    | 20.69      |
| 312    | 7070    | Supplies - Water System Maintenance | 1072 Prairie Material              | 892404188           | 1.0 Cu Yd Concrete - Bennett - 03/25/2026           | 202.25     |
| 313    | 7070    | Supplies - Water System Maintenance | 8244 Des Plaines Ace Hardware      | 9193                | Sump Pump   | 188.99     |
| 314    | 7070    | Supplies - Water System Maintenance | 8244 Des Plaines Ace Hardware      | 9232                | Nipples & Couplings                                 | 31.47      |
| 315    | 7070    | Supplies - Water System Maintenance | 8244 Des Plaines Ace Hardware      | 9239                | 9V Batteries  | 17.99      |
| 316    | 7070    | Supplies - Water System Maintenance | 3217 Ozinga Ready Mix Concrete Inc | ARI03558378         | 12.5 Cu Yds Concrete - 03/30/2026                   | 2,787.63   |
| 317    | 7070    | Supplies - Water System Maintenance | 1703 Prosafety Inc                 | SI004663            | Locating Paint Supplies                             | 284.60     |
| 318    | 7070    | Supplies - Water System Maintenance | 6992 Core & Main LP                | Y249468             | Battery   | 240.15     |
| 319    | 7070    | Supplies - Water System Maintenance | 6992 Core & Main LP                | Y538377             | Returned Battery                                    | (240.15)   |
| 320    | 7070    | Supplies - Water System Maintenance | 6992 Core & Main LP                | Y722889             | Hydrant Flags                                       | 2,390.00   |
| 321    | 7070    | Supplies - Water System Maintenance | 6992 Core & Main LP                | Y724343             | Hydrant Parts                                       | 4,780.00   |
| 322    | 7070    | Supplies - Water System Maintenance | 6992 Core & Main LP                | Y751666             | Gate Valves, Hex Head Bolts, Hex Nuts               | 1,707.75   |
| 323    | 7070    | Supplies - Water System Maintenance | 6992 Core & Main LP                | Y800692             | Flanged Valves, Gaskets, Bolts, Nuts                | 1,458.36   |
| 324    | 7070    | Supplies - Water System Maintenance | 6992 Core & Main LP                | Y800825             | Returned Flanged Valves                             | (1,636.16) |
| 325    | 7070    | Supplies - Water System Maintenance | 6992 Core & Main LP                | Y820721             | Gaskets   | 140.00     |
| 326    | 7120    | Gasoline                            | 1014 Al Warren Oil Company Inc     | W1835356            | 5,019 Gals Unleaded Gasoline - 04/13/2026, R-217-25 | 2,199.43   |

# City of Des Plaines

## Warrant Register 05/04/2026

| Line #                           | Account | Vendor                    | Invoice                             | Invoice Description | Amount  |          |
|----------------------------------|---------|---------------------------|-------------------------------------|---------------------|---|----------|
| 327                              | 7130    | Diesel                    | 1014 Al Warren Oil Company Inc      | W1835355            | 2,001 Gals Bio Diesel Fuel - 04/13/2026, R-217-25 | 2,037.73 |
| 328                              | 7150    | Water Treatment Chemicals | 1082 Alexander Chemical Corporation | 106344              | Chlorine Gas - 02/24-03/30/2026                   | 255.00   |
| 329                              | 7150    | Water Treatment Chemicals | 1082 Alexander Chemical Corporation | 106345              | Chlorine Gas - 02/24-03/30/2026                   | 238.00   |
| 330                              | 7300    | Uniforms                  | 2067 Cutler Workwear                | PS-INV059650        | Boots - Quartermasters                            | 197.95   |
| <b>Total 550 - Water Systems</b> |         |                           |                                     |                     | <b>63,564.53</b>                                  |          |

| <b>Division: 560 - Sewer Systems</b> |      |                                     |  |            |   |          |
|--------------------------------------|------|-------------------------------------|--|------------|---|----------|
| 331                                  | 6505 | Subsidy - Sewer Lateral Program     | 9467 Pham, Tram Anh                      | SLP26-004  | Sewer Rebate SLP26-004 - 04/09/2026                 | 100.00   |
| 332                                  | 7030 | Supplies - Tools & Hardware         | 8244 Des Plaines Ace Hardware            | 8457       | 2 Buckets   | 12.58    |
| 333                                  | 7040 | Supplies - Vehicle R&M              | 1677 Wholesale Direct Inc                | 000278107  | Strobe Lights - PW 8048                             | 290.45   |
| 334                                  | 7040 | Supplies - Vehicle R&M              | 1535 Wipeco Inc                          | 0147907-IN | Shop Rags   | 177.15   |
| 335                                  | 7040 | Supplies - Vehicle R&M              | 2015 Drivetrain Service & Components Inc | 367258     | U-Joints - PW 8045                                  | 115.64   |
| 336                                  | 7040 | Supplies - Vehicle R&M              | 9262 NAPA Auto Parts                     | 951718     | 3 Filters - PW 8045                                 | 140.51   |
| 337                                  | 7075 | Supplies - Sewer System Maintenance | 1437 Des Plaines Material & Supply LLC   | 54809      | Inlet Bottom & Bottom                               | 1,090.00 |
| 338                                  | 7075 | Supplies - Sewer System Maintenance | 5214 State Industrial Products           | 903963690  | Block Worx  | 682.65   |
| 339                                  | 7075 | Supplies - Sewer System Maintenance | 5214 State Industrial Products           | 904088291  | Block Worx  | 753.69   |
| 340                                  | 7075 | Supplies - Sewer System Maintenance | 5214 State Industrial Products           | 904158553  | Block Worx Grease Control - Sewer                   | 753.69   |
| 341                                  | 7075 | Supplies - Sewer System Maintenance | 3008 Norlab Inc                          | 90837      | Tracing Dye   | 843.00   |
| 342                                  | 7075 | Supplies - Sewer System Maintenance | 1703 Prosafety Inc                       | SI004663   | Locating Paint Supplies                             | 284.60   |
| 343                                  | 7120 | Gasoline                            | 1014 Al Warren Oil Company Inc           | W1835356   | 5,019 Gals Unleaded Gasoline - 04/13/2026, R-217-25 | 1,056.06 |
| 344                                  | 7130 | Diesel                              | 1014 Al Warren Oil Company Inc           | W1835355   | 2,001 Gals Bio Diesel Fuel - 04/13/2026, R-217-25   | 1,617.84 |
| <b>Total 560 - Sewer Systems</b>     |      |                                     |  |            | <b>7,917.86</b>                                     |          |

# City of Des Plaines

## Warrant Register 05/04/2026

| Line #                                   | Account | Vendor                | Invoice                              | Invoice Description | Amount   |            |
|--|---------|-----------------------|--------------------------------------|---------------------|--|------------|
| <b>Division: 580 - CIP - Water/Sewer</b> |         |                       |                                      |                     |  |            |
| 345                                      | 6000    | Professional Services | 2506 Trotter & Associates Inc        | 26-26167            | TO#18 CIP Watermains 3/12-3/17/2026, R-218-22                    | 956.00     |
| 346                                      | 6000    | Professional Services | 2506 Trotter & Associates Inc        | 26-26191            | TO#8 Water Modeling & Misc Services 3/23-3/24/2026               | 420.00     |
| 347                                      | 6000    | Professional Services | 2506 Trotter & Associates Inc        | 26-26192            | TO#19 Water Model Refresh-Recalibration 3/16-3/24/2026, R-151-25 | 882.00     |
| 348                                      | 6000    | Professional Services | 1647 RJN Group Inc                   | 435802              | TO#1 MWRD Annual Report - 02/04-03/20/2026, R-233-25             | 5,772.50   |
| 349                                      | 8100    | Improvements          | 3691 A Lamp Concrete Contractors Inc | 2025-WM-P4          | 2025 CIP Water Main Improvements R-130-25, 3/14-4/9/26           | 181,744.11 |
| 350                                      | 8100    | Improvements          | 3530 Mid-American Water              | 468424WD            | Water Main Materials-Mt Prospect/Winthrop - 03/20/2026, R-43-26  | 69,478.40  |
| <b>Total 580 - CIP - Water/Sewer</b>     |         |                       |                                      |                     | <b>259,253.01</b>  |            |

|   |      |                                     |                                    |         |  |          |
|---|------|-------------------------------------|------------------------------------|---------|--|----------|
| <b>Division: 590 - Water Facilities</b> |      |                                     |                                    |         |  |          |
| 351                                     | 6000 | Professional Services               | 5995 Wunderlich-Malec Services Inc | 29213   | TO#8 Scada Services - 12/09-12/15/2025, R-229-23 | 3,716.70 |
| 352                                     | 6000 | Professional Services               | 5995 Wunderlich-Malec Services Inc | 29214   | TO#8 Scada Services - 01/15/2026, R-229-23       | 449.00   |
| 353                                     | 6000 | Professional Services               | 5995 Wunderlich-Malec Services Inc | 29215   | TO#8 Scada Services - 01/20-02/12/2026, R-229-23 | 2,996.25 |
| 354                                     | 6000 | Professional Services               | 5995 Wunderlich-Malec Services Inc | 29216   | TO#8 Scada Services - 02/02/2026, R-229-23       | 346.11   |
| 355                                     | 7070 | Supplies - Water System Maintenance | 6992 Core & Main LP                | Y683085 | 2 Water Meters                                   | 740.00   |
| 356                                     | 7070 | Supplies - Water System Maintenance | 6992 Core & Main LP                | Y757408 | Meter Cables                                     | 3,320.00 |
| <b>Total 590 - Water Facilities</b>     |      |                                     |                                    |         | <b>11,568.06</b>                                 |          |

|                                     |  |  |  |  |                   |
|-------------------------------------|--|--|--|--|-------------------|
| <b>Total 500 - Water/Sewer Fund</b> |  |  |  |  | <b>342,303.46</b> |
|-------------------------------------|--|--|--|--|-------------------|

| <b>Fund: 510 - City Owned Parking Fund</b> |      |                         |                           |                 |  |        |
|--|------|-------------------------|---------------------------|-----------------|--|--------|
| 357  | 6025 | Administrative Services | 7960 Passport Labs Inc    | INV-1059801     | Mobile Pay Parking Transaction Fee - March 2026            | 115.81 |
| 358  | 6320 | R&M Parking Lots        | 2350 Anderson Elevator Co | INV-115925-J7D8 | Elevator Inspections - CH, PD, Metro, Library - April 2026 | 550.00 |

# City of Des Plaines

## Warrant Register 05/04/2026

| Line #                                     | Account | Vendor                  | Invoice                          | Invoice Description | Amount   |        |
|--|---------|-------------------------|----------------------------------|---------------------|--|--------|
| 359  | 7060    | Supplies - Parking Lots | 2028 Northwest Electrical Supply | 17666607            | Light Fixture - Library Parking Deck                   | 790.00 |
| 360  | 7060    | Supplies - Parking Lots | 1057 Menard Incorporated         | 67459               | Gang Box, Connectors, Straps, Blank Cover - Metro Deck | 41.34  |
| <b>Total 510 - City Owned Parking Fund</b> |         |                         |                                  |                     | <b>1,497.15</b>  |        |

| Fund: 520 - Metra Leased Parking Fund        |      |                         |                                     |             |   |          |
|--|------|-------------------------|-------------------------------------|-------------|---|----------|
| 361  | 6025 | Administrative Services | 7960 Passport Labs Inc              | INV-1059801 | Mobile Pay Parking Transaction Fee - March 2026 | 981.24   |
| 362  | 7540 | Land Lease              | 1165 Union Pacific Railroad Company | Mar 2026    | Parking Fees for March 2026                     | 5,245.10 |
| <b>Total 520 - Metra Leased Parking Fund</b> |      |                         |                                     |             | <b>6,226.34</b>                                 |          |

| Fund: 600 - Risk Management Fund        |      |                          |                                  |          |   |          |
|---|------|--------------------------|----------------------------------|----------|---|----------|
| 363                                     | 5570 | Self Insured P&L Expense | 1089 Autokrafters of Des Plaines | 1519     | Accident Repair - PD 6096 - 09/11/2025    | 6,703.91 |
| 364                                     | 6000 | Professional Services    | 8850 Language Line Services Inc  | 11893992 | Interpretation Services Charge 03/31/2026 | 42.18    |
| <b>Total 600 - Risk Management Fund</b> |      |                          |                                  |          | <b>6,746.09</b>                           |          |

| Fund: 700 - Escrow Fund        |      |                                     |                                   |             |  |           |
|--------------------------------|------|-------------------------------------|-----------------------------------|-------------|--|-----------|
| 365                            | 2221 | Taste of Des Plaines                | 6045 Double D Booking             | 32609       | Deposit - Stage Entertainment-Taste of Des Plaines 6/19-6/20/26  | 11,550.00 |
| 366                            | 2224 | Special Event - Food Truck Round Up | 6045 Double D Booking             | 32612       | Entertainment - 3 Food Truck Round Ups 5/19/26, 7/21/26, 8/18/26 | 1,250.00  |
| 367                            | 2231 | Special Events - Harvest Hoot       | 6018 A Moon Jump 4-U Incorporated | 58984505    | Inflatable and Game Deposit for Harvest Hoot 10/17/26            | 1,636.69  |
| 368                            | 2430 | Escrow - Police Items               | 1320 IL State Police              | 20260301755 | Fingerprint Background Check Services March 2026                 | 81.00     |
| <b>Total 700 - Escrow Fund</b> |      |                                     |                                   |             | <b>14,517.69</b>   |           |

|                    |  |  |  |  |                     |
|--------------------|--|--|--|--|---------------------|
| <b>Grand Total</b> |  |  |  |  | <b>2,051,806.34</b> |
|--------------------|--|--|--|--|---------------------|

# City of Des Plaines

## Warrant Register 05/04/2026

### Manual Payments

| Line #                                     | Account | Vendor                 | Invoice                                 | Invoice Description | Amount  |
|--|---------|------------------------|---|---------------------|---|
| <b>Fund: 100 - General Fund</b>            |         |                        |   |                     |   |
| <b>Police Department</b>                   |         |                        |   |                     |   |
| <b>Division: 630 - Support Services</b>    |         |                        |   |                     |   |
| 369  | 6015    | Communication Services | 1009 AT&T                               | 847R185054603-26    | Communications Service 03/28-04/27/2026 64.24       |
| 370  | 7550    | Miscellaneous Expenses | 9462 Polish American Police Association | PAPA2026            | PAPA Award Ceremony 04/24/2026 - 7 Attendees 840.00 |
| <b>Total 630 - Support Services</b>        |         |                        |   |                     | <b>904.24</b>                                       |
| <b>Total 60 - Police Department</b>        |         |                        |   |                     | <b>904.24</b>                                       |
| <b>Fire Department</b>                     |         |                        |   |                     |   |
| <b>Division: 710 - Emergency Services</b>  |         |                        |   |                     |   |
| 371  | 7500    | Postage & Parcel       | 1566 UPS Store The                      | 02/01/2026-FD       | Shipping Charges 02/01/2026 14.34                   |
| <b>Total 710 - Emergency Services</b>      |         |                        |   |                     | <b>14.34</b>  |
| <b>Total 70 - Fire Department</b>          |         |                        |   |                     | <b>14.34</b>  |
| <b>Department: 90 - Overhead</b>           |         |                        |   |                     |   |
| 372  | 6015    | Communication Services | 1032 Comcast                            | 268849797-8482      | Internet/Cable Service 04/15-05/14/2026 1,504.95    |
| 373  | 6015    | Communication Services | 1009 AT&T                               | 334647516-03/26     | Communications Service Apr 2026 73.29               |
| 374  | 6015    | Communication Services | 8536 Peerless Network Inc               | 93902               | Communications Service April 2026 3,736.05          |
| <b>Total 90 - Overhead</b>                 |         |                        |   |                     | <b>5,314.29</b>                                     |
| <b>Total 100 - General Fund</b>            |         |                        |   |                     | <b>6,232.87</b>                                     |
| <b>Fund: 510 - City Owned Parking Fund</b> |         |                        |   |                     |   |
| 375  | 6015    | Communication Services | 8536 Peerless Network Inc               | 93902               | Communications Service April 2026 207.47            |
| 376  | 6015    | Communication Services | 8536 Peerless Network Inc               | 93902               | Communications Service April 2026 153.00            |
| <b>Total 510 - City Owned Parking Fund</b> |         |                        |   |                     | <b>360.47</b>                                       |
| <b>Grand Total</b>                         |         |                        |   |                     | <b>6,593.34</b>                                     |

# City of Des Plaines

## Warrant Register 05/04/2026

### JPMorgan Chase

| Line #  | Account | Vendor                             | Invoice                             | Invoice Description | Amount  |
|---|---------|------------------------------------|-------------------------------------|---------------------|---|
| <b>Fund: 100 - General Fund</b>               |         |                                    |                                     |                     |   |
| <b>Elected Office</b>                         |         |                                    |                                     |                     |   |
| <b>Division: 110 - Legislative</b>            |         |                                    |                                     |                     |   |
| 377   | 7200    | Other Supplies                     | 4348 Amazon.Com                     | PC - 52372          | Personalized Name Badges for Elected Officials 299.75                 |
| <b>Total 110 - Legislative</b>                |         |                                    |                                     |                     | <b>299.75</b>   |
| <b>Total 10 - Elected Office</b>              |         |                                    |                                     |                     | <b>299.75</b>   |
| <b>City Administration</b>                    |         |                                    |                                     |                     |   |
| <b>Division: 210 - City Manager</b>           |         |                                    |                                     |                     |   |
| 378   | 7300    | Uniforms                           | 1538 Lands' End Business Outfitters | PC - 52448          | Des Plaines Logo Wear - Cotton Zip Crew Cardigan 39.37                |
| <b>Total 210 - City Manager</b>               |         |                                    |                                     |                     | <b>39.37</b>  |
| <b>Division: 230 - Information Technology</b> |         |                                    |                                     |                     |   |
| 379   | 6195    | Miscellaneous Contractual Services | 6008 Network Solutions LLC          | PC - 52450          | Renewal Domain Expiration Protection 03/01/2026-02/28/2027 104.16     |
| 380   | 6195    | Miscellaneous Contractual Services | 6008 Network Solutions LLC          | PC - 52451          | Renewal Secure Xpress 03/01/2026-03/31/2026 11.99                     |
| 381   | 6195    | Miscellaneous Contractual Services | 6008 Network Solutions LLC          | PC - 52465          | Renewal Premium DNS Dpcitynet.org 03/01/2026-03/30/2026 14.97         |
| 382   | 6195    | Miscellaneous Contractual Services | 6008 Network Solutions LLC          | PC - 52467          | Renewal Premium DNS Dpcitynet.com 03/01/2026-03/31/2026 4.99          |
| 383   | 6195    | Miscellaneous Contractual Services | 6008 Network Solutions LLC          | PC - 52484          | Renewal Domain Privacy/Protection Dpcitynet.org 03/1-03/31/2026 21.99 |
| 384   | 6195    | Miscellaneous Contractual Services | 6008 Network Solutions LLC          | PC - 52487          | Renewal Secure Xpress 03/01/2026-03/31/2026 11.99                     |
| 385   | 6300    | R&M Software                       | 4639 Google                         | PC - 52449          | Google Workspace 02/01-02/06/2026 3.00                                |
| 386   | 6300    | R&M Software                       | 3875 Apple Inc                      | PC - 52474          | Timestamp Camera Pro App 4/6/2026 10.98                               |
| 387   | 6300    | R&M Software                       | 7392 Microsoft Corporation          | PC - 52476          | Microsoft Teams Shared Devices 03/13/2026-04/12/2026 210.00           |
| 388   | 6300    | R&M Software                       | 9456 Tele-Communication, Inc.       | PC - 52479          | 5 C436HD AudioCodes TEAMS Phones 2,155.20                             |
| 389   | 7200    | Other Supplies                     | 4348 Amazon.Com                     | PC - 52454          | Pack of 50 Shredder Plastic Bags 21.28                                |

# City of Des Plaines

## Warrant Register 05/04/2026

### JPMorgan Chase

| Line #                                    | Account | Vendor              | Invoice         | Invoice Description | Amount                                       |        |
|---|---------|---------------------|-----------------|---------------------|--|--------|
| 390                                       | 7320    | Equipment < \$5,000 | 4348 Amazon.Com | PC - 52455          | 2 Acer USB C Splitters                       | 49.38  |
| 391                                       | 7320    | Equipment < \$5,000 | 4348 Amazon.Com | PC - 52456          | Acer USB C to HDMI Cable                     | 11.99  |
| 392                                       | 7320    | Equipment < \$5,000 | 4348 Amazon.Com | PC - 52457          | 10 Ft. Extension Cord                        | 28.99  |
| 393                                       | 7320    | Equipment < \$5,000 | 4348 Amazon.Com | PC - 52458          | 2 Logitech Wireless Keyboards                | 49.92  |
| 394                                       | 7320    | Equipment < \$5,000 | 4348 Amazon.Com | PC - 52459          | Leviton Extreme Patch Panel Connectors       | 952.35 |
| 395                                       | 7320    | Equipment < \$5,000 | 4348 Amazon.Com | PC - 52460          | Tripp Lite 24 Port Patch Panels              | 267.68 |
| 396                                       | 7320    | Equipment < \$5,000 | 4348 Amazon.Com | PC - 52462          | DisplayPort to DisplayPort Cables            | 156.49 |
| 397                                       | 7320    | Equipment < \$5,000 | 4348 Amazon.Com | PC - 52464          | 2 Ceiling Mount TV Brackets                  | 227.98 |
| 398                                       | 7320    | Equipment < \$5,000 | 4348 Amazon.Com | PC - 52466          | 2 Ubiquiti POE Adapters                      | 42.99  |
| 399                                       | 7320    | Equipment < \$5,000 | 4348 Amazon.Com | PC - 52468          | 24 Pack of Keystone Couplers                 | 20.95  |
| 400                                       | 7320    | Equipment < \$5,000 | 4348 Amazon.Com | PC - 52469          | Ubiquiti POE Adapter                         | 42.99  |
| 401                                       | 7320    | Equipment < \$5,000 | 4348 Amazon.Com | PC - 52470          | 2 Ceiling Mount TV Brackets                  | 154.98 |
| 402                                       | 7320    | Equipment < \$5,000 | 4348 Amazon.Com | PC - 52471          | Network Rack Hardware                        | 22.78  |
| 403                                       | 7320    | Equipment < \$5,000 | 4348 Amazon.Com | PC - 52472          | ReMarkable Plus Pen                          | 129.00 |
| 404                                       | 7320    | Equipment < \$5,000 | 4348 Amazon.Com | PC - 52473          | Network Rack Clip-On                         | 60.00  |
| 405                                       | 7320    | Equipment < \$5,000 | 4348 Amazon.Com | PC - 52475          | 5 Logitech Web Cams                          | 365.55 |
| 406                                       | 7320    | Equipment < \$5,000 | 4348 Amazon.Com | PC - 52478          | 2 25-Packs of Leviton Patch Panel Connectors | 231.40 |
| 407                                       | 7320    | Equipment < \$5,000 | 4348 Amazon.Com | PC - 52481          | Leviton Patch Panel Connectors               | 231.40 |
| 408                                       | 7320    | Equipment < \$5,000 | 4348 Amazon.Com | PC - 52482          | USB to USB C                                 | 10.99  |
| 409                                       | 7320    | Equipment < \$5,000 | 4348 Amazon.Com | PC - 52483          | Logitech Wireless Keyboard                   | 29.99  |
| 410                                       | 7320    | Equipment < \$5,000 | 4348 Amazon.Com | PC - 52485          | Logitech Wireless Keyboards                  | 146.45 |
| 411                                       | 7320    | Equipment < \$5,000 | 4348 Amazon.Com | PC - 52486          | DisplayPort to HDMI Cables                   | 151.90 |
| <b>Total 230 - Information Technology</b> |         |                     |                 |                     | <b>5,956.70</b>                              |        |

# City of Des Plaines

## Warrant Register 05/04/2026

### JPMorgan Chase

| Line #                                | Account | Vendor                             | Invoice                          | Invoice Description   | Amount          |
|---------------------------------------|---------|------------------------------------|----------------------------------|---|-----------------|
| <b>Division: 240 - Media Services</b> |         |                                    |                                  |   |                 |
| 412                                   | 5320    | Conferences                        | 8480 Government Social Media LLC | PC - 52366<br>Virtual Ticket - GSM Conference - Digital Media Spec 5/5-5/7/26 | 519.00          |
| 413                                   | 6195    | Miscellaneous Contractual Services | 8824 Bitly Europe GMBH           | PC - 52421<br>QR Code Generator Services - 03/20/2026-3/20/2027               | 119.88          |
| 414                                   | 6195    | Miscellaneous Contractual Services | 4652 Survey Monkey               | PC - 52515<br>Subscription to Survey Monkey 2/27/26-2/26/27                   | 372.00          |
| 415                                   | 6535    | Subsidy - Youth Commission         | 4348 Amazon.Com                  | PC - 52369<br>Youth Commission Snacks and Giveaways - Fun Fair 03/14/26       | 416.64          |
| 416                                   | 6535    | Subsidy - Youth Commission         | 4348 Amazon.Com                  | PC - 52370<br>Youth Commission Supplies for Fun Fair - 03/14/2026             | 30.03           |
| 417                                   | 6535    | Subsidy - Youth Commission         | 8987 American Button Machines    | PC - 52371<br>Youth Commission Button Making Supplies - Fun Fair 03/14/2026   | 49.38           |
| 418                                   | 6535    | Subsidy - Youth Commission         | 1076 Sam's Club Direct           | PC - 52373<br>Youth Commission Water Bottles - Fun Fair 03/14/2026            | 7.96            |
| 419                                   | 7000    | Office Supplies                    | 4348 Amazon.Com                  | PC - 52518<br>Binders for MS Events, Gloves for Food Truck Round Up 5/19/26   | 23.62           |
| 420                                   | 7320    | Equipment < \$5,000                | 1091 B&H Photo-Video             | PC - 52422<br>Microphone and SD Cards Readers                                 | 357.67          |
| <b>Total 240 - Media Services</b>     |         |                                    |                                  |   | <b>1,896.18</b> |

|  |      |                        |  |  |               |
|--|------|------------------------|--|--|---------------|
| <b>Division: 250 - Human Resources</b> |      |                        |  |  |               |
| 421                                    | 5310 | Membership Dues        | 3248 Society For Human Resource Management | PC - 52377<br>Membership Dues - Director of Human Resources 4/1/26-3/31/27 | 299.00        |
| 422                                    | 5325 | Training               | 1546 IPELRA                                | PC - 52376<br>IPELRA Collective Bargaining Simulation 5/4-5/6/26           | 460.00        |
| 423                                    | 7000 | Office Supplies        | 4348 Amazon.Com                            | PC - 52382<br>3 of 20pcs of Pin Gift Boxes                                 | 39.66         |
| 424                                    | 7550 | Miscellaneous Expenses | 4444 Misc Vendor for Procurement Card      | PC - 52379<br>Deposit - Coffee Truck for PSRW 2026                         | 50.00         |
| <b>Total 250 - Human Resources</b>     |      |                        |  |  | <b>848.66</b> |

|                                       |  |  |  |  |                 |
|---------------------------------------|--|--|--|--|-----------------|
| <b>Total 20 - City Administration</b> |  |  |  |  | <b>8,740.91</b> |
|---------------------------------------|--|--|--|--|-----------------|

# City of Des Plaines

## Warrant Register 05/04/2026

### JPMorgan Chase

| Line #                          | Account | Vendor          | Invoice   | Invoice Description   | Amount          |
|---------------------------------|---------|-----------------|---|---|-----------------|
| <b>Department: 30 - Finance</b> |         |                 |   |   |                 |
| 425                             | 5310    | Membership Dues | 1737 GFOA Government Finance Officers Association | PC - 52508<br>Renewal of Membership Dues 03/01/2026-02/28/2027                | 1,000.00        |
| 426                             | 7000    | Office Supplies | 4348 Amazon.Com                                   | PC - 52503<br>24-Pack of Sharpie Permanent Markers                            | 22.38           |
| 427                             | 7000    | Office Supplies | 4348 Amazon.Com                                   | PC - 52504<br>Post-it Notes, Spiral Notebooks, Pens, Sharpies, Batteries Etc. | 109.76          |
| 428                             | 7200    | Other Supplies  | 4348 Amazon.Com                                   | PC - 52506<br>Post-it Notes, Spiral Notebooks, Pens, Sharpies, Batteries Etc. | 29.48           |
| 429                             | 7200    | Other Supplies  | 1076 Sam's Club Direct                            | PC - 52507<br>Paper Plates, Paper Cups, Lids, K-Cup Coffee                    | 284.50          |
| <b>Total 30 - Finance</b>       |         |                 |   |   | <b>1,446.12</b> |

| <b>Community Development</b>          |      |                 |   |  |                 |
|---------------------------------------|------|-----------------|---|--|-----------------|
| <b>Division: 100 - Administration</b> |      |                 |   |  |                 |
| 430                                   | 5310 | Membership Dues | 7034 American Planning Association - Illinois Chapter | PC - 52512<br>APA/AICP Membership Dues CED Dir - 4/1/26-3/31/27            | 776.50          |
| 431                                   | 5320 | Conferences     | 9075 IL Assoc of Municipal Mgmt Assistants IAMMA      | PC - 52488<br>CED Mgmt Analyst Network Conference 04/17/2026               | 75.00           |
| 432                                   | 5320 | Conferences     | 2489 American Planning Association                    | PC - 52511<br>APA IL State Conf. - CED Dir 4/25/26-4/28/26                 | 935.00          |
| 433                                   | 7000 | Office Supplies | 4348 Amazon.Com                                       | PC - 52416<br>Pens, AAA V9 Batteries, Post-It Notes, White Out, Copy Paper | 105.75          |
| 434                                   | 7200 | Other Supplies  | 4348 Amazon.Com                                       | PC - 52413<br>Coffee K-Cups  | 46.48           |
| 435                                   | 7300 | Uniforms        | 1538 Lands' End Business Outfitters                   | PC - 52513<br>CED Uniforms   | 49.66           |
| <b>Total 100 - Administration</b>     |      |                 |   |  | <b>1,988.39</b> |

| <b>Division: 410 - Building &amp; Code Enforcement</b> |      |                 |  |  |               |
|--|------|-----------------|--|--|---------------|
| 436  | 5325 | Training        | 5331 IL Plumbing Heating Cooling Contractors Assoc | PC - 52412<br>Plumb Inspector Training 03/20/2026                          | 35.00         |
| 437  | 7000 | Office Supplies | 4348 Amazon.Com                                    | PC - 52415<br>Pens, AAA V9 Batteries, Post-It Notes, White Out, Copy Paper | 167.42        |
| 438  | 7200 | Other Supplies  | 4348 Amazon.Com                                    | PC - 52414<br>Coffee K-Cups  | 52.13         |
| 439  | 7300 | Uniforms        | 1538 Lands' End Business Outfitters                | PC - 52510<br>Bldg and Code/CED Uniforms                                   | 33.16         |
| <b>Total 410 - Building &amp; Code Enforcement</b>     |      |                 |  |  | <b>287.71</b> |

# City of Des Plaines

## Warrant Register 05/04/2026

### JPMorgan Chase

| Line #                                       | Account | Vendor      | Invoice                            | Invoice Description  | Amount        |
|--|---------|-------------|------------------------------------|--|---------------|
| <b>Division: 420 - Planning &amp; Zoning</b> |         |             |                                    |  |               |
| 440  | 5320    | Conferences | 2489 American Planning Association | PC - 52509<br>APA Conf - Asst Director Planning/Zoning 4/25/26-4/28/26 | 917.00        |
| <b>Total 420 - Planning &amp; Zoning</b>     |         |             |                                    |  | <b>917.00</b> |

|   |  |  |  |  |                 |
|---|--|--|--|--|-----------------|
| <b>Total 40 - Community Development</b> |  |  |  |  | <b>3,193.10</b> |
|---|--|--|--|--|-----------------|

| <b>Public Works &amp; Engineering</b> |      |                 |  |            |  |          |
|---------------------------------------|------|-----------------|--|------------|--|----------|
| <b>Division: 100 - Administration</b> |      |                 |  |            |  |          |
| 441                                   | 5310 | Membership Dues | 4444 Misc Vendor for Procurement Card            | PC - 52375 | ICLEI Annual Membership - 04/01/2026-03/31/2027          | 2,200.00 |
| 442                                   | 5320 | Conferences     | 9075 IL Assoc of Municipal Mgmt Assistants IAMMA | PC - 52367 | IAMMA Conference Registration Fee - Mgmt Analyst 4/17/26 | 75.00    |
| <b>Total 100 - Administration</b>     |      |                 |  |            | <b>2,275.00</b>  |          |

|                                    |      |                       |   |            |  |       |
|------------------------------------|------|-----------------------|---|------------|--|-------|
| <b>Division: 510 - Engineering</b> |      |                       |   |            |  |       |
| 443                                | 6000 | Professional Services | 1753 American Public Works Association - APWA | PC - 52339 | National Public Works Week Poster 02/27/2026 | 21.00 |
| <b>Total 510 - Engineering</b>     |      |                       |   |            | <b>21.00</b>                                 |       |

|   |      |                       |   |            |  |          |
|---|------|-----------------------|---|------------|--|----------|
| <b>Division: 530 - Street Maintenance</b> |      |                       |   |            |  |          |
| 444                                       | 5310 | Membership Dues       | 5441 International Society of Arboriculture | PC - 52409 | IL Arborist Association Dues - 3/25/2026-3/24/2027 - Foreman   | 55.00    |
| 445                                       | 6000 | Professional Services | 4639 Google                                 | PC - 52408 | Google Workspace Account for Filling Out IDOT Forms - Mar 2026 | 16.80    |
| 446                                       | 7200 | Other Supplies        | 9301 Alco Covers LLC                        | PC - 52410 | Tarp for Road Salt Stockpile                                   | 2,585.99 |
| 447                                       | 7200 | Other Supplies        | 9301 Alco Covers LLC                        | PC - 52411 | Tarp for Road Salt Stockpile                                   | 3,194.99 |
| <b>Total 530 - Street Maintenance</b>     |      |                       |   |            | <b>5,852.78</b>  |          |

|   |      |                            |                 |            |   |          |
|---|------|----------------------------|-----------------|------------|---|----------|
| <b>Division: 535 - Facilities &amp; Grounds Maintenance</b> |      |                            |                 |            |   |          |
| 448   | 6315 | R&M Buildings & Structures | 7689 Ambius     | PC - 52420 | March 2026 Monthly Plant Maintenance                    | 939.40   |
| 449   | 7045 | Supplies - Building R&M    | 4348 Amazon.Com | PC - 52340 | Poster Frames   | 196.08   |
| 450   | 7045 | Supplies - Building R&M    | 4348 Amazon.Com | PC - 52490 | Data Panels, Connectors and Cable - City Hall 3rd Floor | 1,030.90 |
| 451   | 7045 | Supplies - Building R&M    | 4348 Amazon.Com | PC - 52491 | Data D-Rings for Cables - City Hall 3rd Floor           | 138.97   |

# City of Des Plaines

## Warrant Register 05/04/2026

### JPMorgan Chase

| Line #  | Account | Vendor                  | Invoice                | Invoice Description | Amount  |          |
|---|---------|-------------------------|------------------------|---------------------|---|----------|
| 452   | 7045    | Supplies - Building R&M | 4348 Amazon.Com        | PC - 52492          | Data Panels, Connectors and Cable - City Hall 3rd Floor | 207.30   |
| 453   | 7045    | Supplies - Building R&M | 9454 Wolf-Gordon, Inc. | PC - 52493          | Wall Protection - City Hall 3rd Floor                   | 4,635.25 |
| 454   | 7045    | Supplies - Building R&M | 9454 Wolf-Gordon, Inc. | PC - 52494          | Wall Protection - City Hall 3rd Floor                   | 69.53    |
| 455   | 7045    | Supplies - Building R&M | 4348 Amazon.Com        | PC - 52495          | Data Connectors - City Hall 3rd Floor                   | 1,631.54 |
| 456   | 7200    | Other Supplies          | 4348 Amazon.Com        | PC - 52496          | Coffee - City Hall                                      | 239.96   |
| 457   | 8010    | Furniture & Fixtures    | 4348 Amazon.Com        | PC - 52489          | Chair for Roll Call Room - PD                           | 74.99    |
| <b>Total 535 - Facilities &amp; Grounds Maintenance</b> |         |                         |                        |                     | <b>9,163.92</b>   |          |

| <b>Division: 540 - Vehicle Maintenance</b> |      |                             |                                       |            |  |        |
|--|------|-----------------------------|---------------------------------------|------------|--|--------|
| 458  | 5325 | Training                    | 7048 EVT Certification Commission Inc | PC - 52355 | EVT Fire and Ambulance Testing - 03/25/2026 - Mechanic | 135.00 |
| 459  | 7030 | Supplies - Tools & Hardware | 4348 Amazon.Com                       | PC - 52353 | Flat Wrenches - PW Shop                                | 42.54  |
| 460  | 7035 | Supplies - Equipment R&M    | 4348 Amazon.Com                       | PC - 52348 | Air Compressor Oil - PW 5PW4                           | 307.86 |
| 461  | 7035 | Supplies - Equipment R&M    | 4348 Amazon.Com                       | PC - 52349 | Filters and Spark Plugs - PW Stock                     | 35.08  |
| 462  | 7035 | Supplies - Equipment R&M    | 4348 Amazon.Com                       | PC - 52357 | Chipper Belt - PW 5041                                 | 358.98 |
| 463  | 7035 | Supplies - Equipment R&M    | 4348 Amazon.Com                       | PC - 52358 | AGM Battery Tender - PD 6930                           | 107.86 |
| 464  | 7040 | Supplies - Vehicle R&M      | 4348 Amazon.Com                       | PC - 52350 | LED Strobes - PW 5162                                  | 225.38 |
| 465  | 7040 | Supplies - Vehicle R&M      | 4348 Amazon.Com                       | PC - 52351 | Head Lights - FD Stock                                 | 478.16 |
| 466  | 7040 | Supplies - Vehicle R&M      | 4348 Amazon.Com                       | PC - 52352 | Sweeper Brooms - PW 5153                               | 818.28 |
| 467  | 7040 | Supplies - Vehicle R&M      | 4348 Amazon.Com                       | PC - 52356 | LED Strobe Lights - PW 5162                            | 239.98 |
| <b>Total 540 - Vehicle Maintenance</b>     |      |                             |                                       |            | <b>2,749.12</b>  |        |

|  |  |  |  |  |                  |
|--|--|--|--|--|------------------|
| <b>Total 50 - Public Works &amp; Engineering</b> |  |  |  |  | <b>20,061.82</b> |
|--|--|--|--|--|------------------|

# City of Des Plaines

## Warrant Register 05/04/2026

### JPMorgan Chase

| Line #                                  | Account | Vendor              | Invoice                               | Invoice Description | Amount  |        |
|---|---------|---------------------|---------------------------------------|---------------------|---|--------|
| <b>Police Department</b>                |         |                     |                                       |                     |   |        |
| <b>Division: 610 - Uniformed Patrol</b> |         |                     |                                       |                     |   |        |
| 468                                     | 5325    | Training            | 7781 Law Enforcement Seminars LLC     | PC - 52345          | Background Investigations Class 6/18-6/16/2026 (1 Cmdr)         | 445.00 |
| 469                                     | 5325    | Training            | 4444 Misc Vendor for Procurement Card | PC - 52347          | Lodging - Accident Reconstruction Training 3/24-3/26/26 (1 Ofc) | 898.32 |
| 470                                     | 7200    | Other Supplies      | 1047 Home Depot Credit Svcs           | PC - 52435          | Shop Vac, Towels, Hose, Shelf, Cleaning Supplies                | 108.80 |
| 471                                     | 7320    | Equipment < \$5,000 | 1047 Home Depot Credit Svcs           | PC - 52434          | Shop Vac, Towels, Hose, Shelf, Cleaning Supplies                | 360.58 |
| <b>Total 610 - Uniformed Patrol</b>     |         |                     |                                       |                     | <b>1,812.70</b>   |        |

|   |      |                        |   |            |  |        |
|---|------|------------------------|---|------------|--|--------|
| <b>Division: 620 - Criminal Investigation</b> |      |                        |   |            |  |        |
| 472   | 5310 | Membership Dues        | 1438 Association of Police Social Workers | PC - 52497 | 2026 Membership Dues for 2 Social Workers                    | 150.00 |
| 473   | 5325 | Training               | 4444 Misc Vendor for Procurement Card     | PC - 52384 | Cultural Competence (1 Soc Wrk) Online 3/11/2026             | 35.00  |
| 474   | 5325 | Training               | 4444 Misc Vendor for Procurement Card     | PC - 52385 | Implicit Bias in Counseling (1 Soc Wrk) Online 3/11/2026     | 65.00  |
| 475   | 5325 | Training               | 4444 Misc Vendor for Procurement Card     | PC - 52386 | Ethics and Professional Issues (1 Soc Wrk) Online 3/11/2026  | 35.00  |
| 476   | 5325 | Training               | 4444 Misc Vendor for Procurement Card     | PC - 52387 | Sexual Harassment Awareness (1 Soc Wrk) Online 3/11/2026     | 35.00  |
| 477   | 6015 | Communication Services | 8347 Browning Trail Cameras               | PC - 52344 | Cell Connection - Trail Camera for Surveillance 3/7-4/7/2026 | 29.99  |
| <b>Total 620 - Criminal Investigation</b>     |      |                        |   |            | <b>349.99</b>  |        |

|   |      |                 |                     |            |   |            |
|---|------|-----------------|---------------------|------------|---|------------|
| <b>Division: 630 - Support Services</b> |      |                 |                     |            |   |            |
| 478                                     | 6300 | R&M Software    | 6695 Finalcover LLC | PC - 52499 | Video Redaction Software - Charged in Error               | 3,588.00   |
| 479                                     | 6300 | R&M Software    | 6695 Finalcover LLC | PC - 52500 | Refund - Video Redaction Software - Charged in Error      | (3,588.00) |
| 480                                     | 7000 | Office Supplies | 4348 Amazon.Com     | PC - 52391 | Magnetic Wall Files                                       | 55.48      |
| 481                                     | 7000 | Office Supplies | 4348 Amazon.Com     | PC - 52393 | Magnetic File Folders, Cubicle Clips                      | 42.01      |
| 482                                     | 7000 | Office Supplies | 4348 Amazon.Com     | PC - 52394 | Magnetic Hooks, Batteries                                 | 60.82      |
| 483                                     | 7000 | Office Supplies | 4348 Amazon.Com     | PC - 52396 | Paper   | 23.01      |
| 484                                     | 7000 | Office Supplies | 4348 Amazon.Com     | PC - 52398 | Business Card Magnets, Post Its, Paper, USB Adapter, Etc. | 104.82     |

# City of Des Plaines

## Warrant Register 05/04/2026

### JPMorgan Chase

| Line #                              | Account | Vendor              | Invoice                               | Invoice Description | Amount  |         |
|-------------------------------------|---------|---------------------|---------------------------------------|---------------------|---|---------|
| 485                                 | 7000    | Office Supplies     | 4348 Amazon.Com                       | PC - 52399          | Refund for Magnetic File Folders                  | (24.00) |
| 486                                 | 7000    | Office Supplies     | 4348 Amazon.Com                       | PC - 52401          | Envelopes, Cable Clips, USB Cable, Extension Cord | 40.31   |
| 487                                 | 7000    | Office Supplies     | 4348 Amazon.Com                       | PC - 52403          | Return for 2 Phone Charging Cables                | (30.38) |
| 488                                 | 7000    | Office Supplies     | 4348 Amazon.Com                       | PC - 52404          | Compressed Air Dusters                            | 29.38   |
| 489                                 | 7200    | Other Supplies      | 4348 Amazon.Com                       | PC - 52363          | Disinfectant Wipes                                | 124.95  |
| 490                                 | 7300    | Uniforms            | 1538 Lands' End Business Outfitters   | PC - 52389          | Uniforms for Civilian Employees                   | 866.70  |
| 491                                 | 7300    | Uniforms            | 1538 Lands' End Business Outfitters   | PC - 52390          | Uniforms for Civilian Employees                   | 69.04   |
| 492                                 | 7300    | Uniforms            | 1538 Lands' End Business Outfitters   | PC - 52392          | Uniforms for Civilian Employees                   | 27.92   |
| 493                                 | 7300    | Uniforms            | 1538 Lands' End Business Outfitters   | PC - 52395          | Uniforms for Civilian Employees                   | 31.92   |
| 494                                 | 7300    | Uniforms            | 1538 Lands' End Business Outfitters   | PC - 52397          | Uniforms for Civilian Employees                   | 58.39   |
| 495                                 | 7300    | Uniforms            | 1538 Lands' End Business Outfitters   | PC - 52400          | Uniforms for Civilian Employees                   | 38.77   |
| 496                                 | 7320    | Equipment < \$5,000 | 4348 Amazon.Com                       | PC - 52346          | Cord Carrying Straps                              | 47.15   |
| 497                                 | 7320    | Equipment < \$5,000 | 4444 Misc Vendor for Procurement Card | PC - 52383          | Survival Blankets and Tourniquets                 | 181.25  |
| 498                                 | 7320    | Equipment < \$5,000 | 4348 Amazon.Com                       | PC - 52402          | 2 Garage Door Remotes                             | 69.90   |
| 499                                 | 7500    | Postage & Parcel    | 1700 United States Postal Service     | PC - 52502          | Shipping Tint Readers for Repair 3/19/2026        | 14.55   |
| <b>Total 630 - Support Services</b> |         |                     |                                       |                     | <b>1,831.99</b>                                   |         |

|                                     |                 |
|-------------------------------------|-----------------|
| <b>Total 60 - Police Department</b> | <b>3,994.68</b> |
|-------------------------------------|-----------------|

| Fire Department                   |      |                 |   |            |  |       |
|-----------------------------------|------|-----------------|---|------------|--|-------|
| Division: 100 - Administration    |      |                 |   |            |  |       |
| 500                               | 5310 | Membership Dues | 1482 Metropolitan Fire Chiefs Association of Illinois | PC - 52405 | Membership Dues - Fire Chief 1/1/26-12/31/26                   | 50.00 |
| 501                               | 7200 | Other Supplies  | 4633 Walgreen Co                                      | PC - 52406 | Plates, Plasticware and Cookies - Promotional Ceremony 3/16/26 | 37.76 |
| <b>Total 100 - Administration</b> |      |                 |   |            | <b>87.76</b>   |       |

| Division: 710 - Emergency Services |      |          |                                       |            |   |        |
|------------------------------------|------|----------|---------------------------------------|------------|---|--------|
| 502                                | 5325 | Training | 4444 Misc Vendor for Procurement Card | PC - 52437 | 3 Classes FDIC 04/20-04/25/2026 - 1 Paramedic   | 719.00 |
| 503                                | 5325 | Training | 4444 Misc Vendor for Procurement Card | PC - 52438 | First Due Symposium - 2 Paramedics - 04/25/2026 | 178.76 |

# City of Des Plaines

## Warrant Register 05/04/2026

### JPMorgan Chase

| Line #                                | Account | Vendor                     | Invoice                             | Invoice Description | Amount   |        |
|---------------------------------------|---------|----------------------------|-------------------------------------|---------------------|--|--------|
| 504                                   | 6115    | Licensing/Titles           | 1472 IL Department of Public Health | PC - 52440          | 2026 Annual Ambulance Inspections                          | 153.38 |
| 505                                   | 6115    | Licensing/Titles           | 1472 IL Department of Public Health | PC - 52441          | Paramedic License Renewal - 03/31/2026-03/31/2030          | 41.00  |
| 506                                   | 6115    | Licensing/Titles           | 1472 IL Department of Public Health | PC - 52442          | Paramedic License Renewal 03/31/2026-03/31/2030            | 41.00  |
| 507                                   | 6115    | Licensing/Titles           | 1472 IL Department of Public Health | PC - 52443          | EMT License Renewal - 04/30/2026-04/30/2030 - Deputy Chief | 21.00  |
| 508                                   | 6315    | R&M Buildings & Structures | 1557 Abt Electronics & Appliances   | PC - 52425          | Washing Machine Repair Balance - Station 61 - 01/08/2026   | 21.49  |
| 509                                   | 7000    | Office Supplies            | 4348 Amazon.Com                     | PC - 52436          | 2 Boxes of 3 Ring Binders                                  | 68.58  |
| 510                                   | 7200    | Other Supplies             | 4348 Amazon.Com                     | PC - 52338          | 3 Toilet Paper Roll Holders                                | 86.97  |
| 511                                   | 7200    | Other Supplies             | 7767 Quench USA Inc                 | PC - 52428          | Water Dispenser Station 61 - 02/28-05/31/2026              | 328.36 |
| 512                                   | 7200    | Other Supplies             | 4348 Amazon.Com                     | PC - 52432          | Refund for Delivery Fees                                   | (6.99) |
| 513                                   | 7200    | Other Supplies             | 1047 Home Depot Credit Svcs         | PC - 52439          | 36 OSB Boards and Supplies for Fire Training               | 792.26 |
| 514                                   | 7200    | Other Supplies             | 4348 Amazon.Com                     | PC - 52444          | 1 Streamlight Lantern                                      | 253.42 |
| 515                                   | 7200    | Other Supplies             | 4348 Amazon.Com                     | PC - 52498          | 1 Pry Opening Tool   | 25.98  |
| 516                                   | 7320    | Equipment < \$5,000        | 4348 Amazon.Com                     | PC - 52427          | 1 Evacuation Triangle                                      | 100.96 |
| 517                                   | 7320    | Equipment < \$5,000        | 4348 Amazon.Com                     | PC - 52429          | 1 Nylon Web Anchor Strap                                   | 33.65  |
| 518                                   | 7320    | Equipment < \$5,000        | 4348 Amazon.Com                     | PC - 52430          | 2 Helmets  | 784.75 |
| 519                                   | 7320    | Equipment < \$5,000        | 4348 Amazon.Com                     | PC - 52431          | 2 Pack of Garage Remote Control                            | 26.34  |
| 520                                   | 7320    | Equipment < \$5,000        | 4348 Amazon.Com                     | PC - 52433          | 5 Charging Packs   | 81.24  |
| 521                                   | 7550    | Miscellaneous Expenses     | 6867 Marianos                       | PC - 52426          | Cake for Promotional Ceremony - 03/16/2026                 | 36.80  |
| <b>Total 710 - Emergency Services</b> |         |                            |                                     |                     | <b>3,787.95</b>  |        |

| <b>Division: 720 - Fire Prevention</b> |      |                     |                                |            |   |        |
|--|------|---------------------|--------------------------------|------------|---|--------|
| 522                                    | 5310 | Membership Dues     | 1551 IL Fire Inspectors Assoc  | PC - 52424 | IL Fire Insp Membership Dues- Fire Prevention 01/01/26-01/01/27 | 100.00 |
| 523                                    | 7320 | Equipment < \$5,000 | 1018 Anderson Lock Company LTD | PC - 52417 | 3 Brass Tags  | 3.36   |
| <b>Total 720 - Fire Prevention</b>     |      |                     |                                |            | <b>103.36</b>   |        |

|                                   |  |  |  |  |                 |
|-----------------------------------|--|--|--|--|-----------------|
| <b>Total 70 - Fire Department</b> |  |  |  |  | <b>3,979.07</b> |
|-----------------------------------|--|--|--|--|-----------------|

# City of Des Plaines

## Warrant Register 05/04/2026

### JPMorgan Chase

| Line #   | Account | Vendor                 | Invoice                               | Invoice Description   | Amount        |
|--|---------|------------------------|---------------------------------------|---|---------------|
| <b>Department: 75 - Fire &amp; Police Commission</b> |         |                        |                                       |   |               |
| 524  | 7550    | Miscellaneous Expenses | 4444 Misc Vendor for Procurement Card | PC - 52378<br>Lunch for 3/9/2026 MAP240 Negotiations              | 99.84         |
| 525  | 7550    | Miscellaneous Expenses | 4444 Misc Vendor for Procurement Card | PC - 52380<br>Lunch for 3/17/2026 BFPC Special Meeting            | 159.14        |
| 526  | 7550    | Miscellaneous Expenses | 4444 Misc Vendor for Procurement Card | PC - 52381<br>Tax Refund-Lunch for 3/17/2026 BFPC Special Meeting | (0.50)        |
| <b>Total 75 - Fire &amp; Police Commission</b>       |         |                        |                                       |   | <b>258.48</b> |

|                                 |                  |
|---------------------------------|------------------|
| <b>Total 100 - General Fund</b> | <b>41,973.93</b> |
|---------------------------------|------------------|

| <b>Fund: 260 - Asset Seizure Fund</b> |      |                         |   |  |                 |
|---------------------------------------|------|-------------------------|---|--|-----------------|
| <b>Program: 2620 - DEA</b>            |      |                         |   |  |                 |
| 527                                   | 5345 | Post-Employment Testing | 2377 North Shore University Health System | PC - 52388<br>Nipas Physical (1 Ofc) 3/27/2026         | 625.00          |
| 528                                   | 7015 | Supplies - Police Range | 4444 Misc Vendor for Procurement Card     | PC - 52364<br>Moving Targets for TRT                   | 620.00          |
| 529                                   | 7200 | Other Supplies          | 4444 Misc Vendor for Procurement Card     | PC - 52360<br>Gas Mask Filter Mount Converter Kits     | 173.46          |
| 530                                   | 7200 | Other Supplies          | 4348 Amazon.Com                           | PC - 52365<br>Chem Lights                              | 130.69          |
| 531                                   | 7200 | Other Supplies          | 7186 Bentley's Pet Stuff-SC               | PC - 52407<br>Food and Token for Dog Wash for K9 Jager | 111.59          |
| 532                                   | 7320 | Equipment < \$5,000     | 4444 Misc Vendor for Procurement Card     | PC - 52359<br>Gas Mask and Filter                      | 677.90          |
| 533                                   | 7320 | Equipment < \$5,000     | 5854 MidwayUSA                            | PC - 52361<br>M-LOK Picatinny Rails for TRT            | 80.80           |
| 534                                   | 7320 | Equipment < \$5,000     | 5854 MidwayUSA                            | PC - 52362<br>Slings and Sling Mount for TRT           | 727.49          |
| <b>Total 2620 - DEA</b>               |      |                         |   |  | <b>3,146.93</b> |

|                                |      |                  |                            |   |               |
|--------------------------------|------|------------------|----------------------------|---|---------------|
| <b>Program: 2640 - Forfeit</b> |      |                  |                            |   |               |
| 535                            | 6115 | Licensing/Titles | 1744 IL Secretary of State | PC - 52501<br>Squad #2 Vehicle Registration 2026-2027 License Plate BY64246 | 154.40        |
| <b>Total 2640 - Forfeit</b>    |      |                  |                            |   | <b>154.40</b> |

|                                       |                 |
|---------------------------------------|-----------------|
| <b>Total 260 - Asset Seizure Fund</b> | <b>3,301.33</b> |
|---------------------------------------|-----------------|

| <b>Fund: 400 - Capital Projects Fund</b> |      |                                    |  |   |               |
|--|------|------------------------------------|--|---|---------------|
| 536                                      | 6195 | Miscellaneous Contractual Services | 6035 IL Dept of Natural Resources IDNR | PC - 52368<br>Endangered Species Investigation - Led Service Repl 3/23/26 | 127.81        |
| <b>Total 400 - Capital Projects Fund</b> |      |                                    |  |   | <b>127.81</b> |

# City of Des Plaines

## Warrant Register 05/04/2026

### JPMorgan Chase

| Line #                                 | Account | Vendor            | Invoice         | Invoice Description | Amount                      |          |
|--|---------|-------------------|-----------------|---------------------|-----------------------------|----------|
| <b>Fund: 420 - IT Replacement Fund</b> |         |                   |                 |                     |                             |          |
| 537                                    | 8005    | Computer Hardware | 4348 Amazon.Com | PC - 52452          | ReMarkable Paper Pro Tablet | 799.00   |
| 538                                    | 8005    | Computer Hardware | 4348 Amazon.Com | PC - 52453          | Lithium UPS Battery Backup  | 580.53   |
| 539                                    | 8005    | Computer Hardware | 4348 Amazon.Com | PC - 52461          | 2 APC 2200 Smart UPS        | 2,089.30 |
| 540                                    | 8005    | Computer Hardware | 4348 Amazon.Com | PC - 52463          | 10 APC 600 UPS's            | 1,029.40 |
| 541                                    | 8005    | Computer Hardware | 4348 Amazon.Com | PC - 52477          | Lithium UPS Battery Back Up | 199.49   |
| 542                                    | 8005    | Computer Hardware | 4348 Amazon.Com | PC - 52480          | 3 APC 1500 Smart UPS        | 1,784.97 |
| <b>Total 420 - IT Replacement Fund</b> |         |                   |                 |                     | <b>6,482.69</b>             |          |

|  |      |                                    |   |            |  |          |
|--|------|------------------------------------|---|------------|--|----------|
| <b>Fund: 430 - Facilities Replacement Fund</b> |      |                                    |   |            |  |          |
| 543  | 6195 | Miscellaneous Contractual Services | 1646 Metropolitan Water Reclamation Dist of Greater Chg | PC - 52374 | MWRD Permit Fee - 678 Lee Street 3/19/2026 | 1,424.80 |
| <b>Total 430 - Facilities Replacement Fund</b> |      |                                    |   |            | <b>1,424.80</b>                            |          |

|                                      |      |                                     |                                |            |                            |        |
|--------------------------------------|------|-------------------------------------|--------------------------------|------------|----------------------------|--------|
| <b>Fund: 500 - Water/Sewer Fund</b>  |      |                                     |                                |            |                            |        |
| <b>Non Departmental</b>              |      |                                     |                                |            |                            |        |
| <b>Division: 550 - Water Systems</b> |      |                                     |                                |            |                            |        |
| 544                                  | 7070 | Supplies - Water System Maintenance | 8586 Flight Light Incorporated | PC - 52418 | Aviation Light Water Tower | 693.15 |
| 545                                  | 7070 | Supplies - Water System Maintenance | 4348 Amazon.Com                | PC - 52419 | Screen for Towers          | 23.58  |
| 546                                  | 7070 | Supplies - Water System Maintenance | 4348 Amazon.Com                | PC - 52514 | Fish Tapes and Mouse Pad   | 292.01 |
| <b>Total 550 - Water Systems</b>     |      |                                     |                                |            | <b>1,008.74</b>            |        |

|                                      |      |                        |                 |            |   |       |
|--------------------------------------|------|------------------------|-----------------|------------|---|-------|
| <b>Division: 560 - Sewer Systems</b> |      |                        |                 |            |   |       |
| 547                                  | 7040 | Supplies - Vehicle R&M | 4348 Amazon.Com | PC - 52354 | Hitch Adapters and Wiring - Sewer Stock | 90.39 |
| <b>Total 560 - Sewer Systems</b>     |      |                        |                 |            | <b>90.39</b>                            |       |

|                                    |  |  |  |  |                 |
|------------------------------------|--|--|--|--|-----------------|
| <b>Total 00 - Non Departmental</b> |  |  |  |  | <b>1,099.13</b> |
|------------------------------------|--|--|--|--|-----------------|

# City of Des Plaines

## Warrant Register 05/04/2026

### JPMorgan Chase

| Line #                                  | Account | Vendor                              | Invoice                            | Invoice Description | Amount  |          |
|---|---------|-------------------------------------|------------------------------------|---------------------|---|----------|
| <b>Department: 30 - Finance</b>         |         |                                     |                                    |                     |   |          |
| 548                                     | 7000    | Office Supplies                     | 4348 Amazon.Com                    | PC - 52505          | Post-it Notes, Spiral Notebooks, Pens, Sharpies, Batteries Etc. | 109.75   |
| <b>Total 30 - Finance</b>               |         |                                     |                                    |                     | <b>109.75</b>   |          |
| <b>Total 500 - Water/Sewer Fund</b>     |         |                                     |                                    |                     | <b>1,208.88</b>   |          |
| <b>Fund: 600 - Risk Management Fund</b> |         |                                     |                                    |                     |   |          |
| 549                                     | 5325    | Training                            | 9441 Voila Nutrition               | PC - 52423          | 2 Fire Department Nutrition Classes - 02/25/2026, 02/27/2026    | 1,050.00 |
| <b>Total 600 - Risk Management Fund</b> |         |                                     |                                    |                     | <b>1,050.00</b>   |          |
| <b>Fund: 700 - Escrow Fund</b>          |         |                                     |                                    |                     |   |          |
| 550                                     | 2221    | Taste of Des Plaines                | 6928 Fun Express LLC               | PC - 52446          | Glow Sticks-Taste of DP 6/19-20/26, Float Decor-Parade 7/4/26   | 269.96   |
| 551                                     | 2221    | Taste of Des Plaines                | 1076 Sam's Club Direct             | PC - 52517          | Games for Food Truck 5/19, Forks-Taste Staff Meals 6/18-6/20/26 | 14.68    |
| 552                                     | 2224    | Special Event - Food Truck Round Up | 9119 Wild Bills Bubble Madness LLC | PC - 52445          | Bubble Activity Deposit for Food Truck Round Up 5/19/26         | 50.00    |
| 553                                     | 2224    | Special Event - Food Truck Round Up | 1076 Sam's Club Direct             | PC - 52516          | Games for Food Truck 5/19, Forks-Taste Staff Meals 6/18-6/20/26 | 70.96    |
| 554                                     | 2224    | Special Event - Food Truck Round Up | 4348 Amazon.Com                    | PC - 52519          | Binders for MS Events, Gloves for Food Truck Round Up 5/19/26   | 16.48    |
| 555                                     | 2226    | Special Events - July 4th           | 6928 Fun Express LLC               | PC - 52447          | Glow Sticks-Taste of DP 6/19-20/26, Float Decor-Parade 7/4/26   | 1,378.68 |
| 556                                     | 2229    | Event - Holiday Lighting            | 8728 Way To Go Limousine Inc       | PC - 52520          | Trolley #1 Deposit for Winter Fair 12/5/26                      | 355.00   |
| 557                                     | 2229    | Event - Holiday Lighting            | 8728 Way To Go Limousine Inc       | PC - 52521          | Trolley #2 Deposit for Winter Fair 12/5/26                      | 356.00   |
| <b>Total 700 - Escrow Fund</b>          |         |                                     |                                    |                     | <b>2,511.76</b>   |          |
| <b>Grand Total</b>                      |         |                                     |                                    |                     | <b>58,081.20</b>  |          |

# City of Des Plaines

## Warrant Register 05/04/2026

### Summary

|                                  | <u>Amount</u>                 | <u>Transfer Date</u> |
|----------------------------------|-------------------------------|----------------------|
| Automated Accounts Payable       | \$ 2,051,806.34 **            | 5/4/2026             |
| Manual Checks                    | \$ 6,593.34 **                | 4/17/2026            |
| Payroll                          | \$ 1,512,907.24               | 4/17/2026            |
| RHS Payout                       | \$ -                          |                      |
| Electronic Transfer Activity:    |                               |                      |
| JPMorgan Chase Credit Card       | \$ 58,081.20 **               | 4/25/2026            |
| Chicago Water Bill ACH           | \$ 197,701.65                 | 4/30/2026            |
| Postage - Pitney Bowes           | \$ 3,000.00                   | 4/15/2026            |
| Postage - USPS Access Point      | \$ -                          |                      |
| Postage - Sebis                  | \$ -                          |                      |
| Property Purchase                | \$ -                          |                      |
| Utility Billing Refunds          | \$ -                          |                      |
| Debt Interest Payment            | \$ -                          |                      |
| Unclaimed Property               | \$ -                          |                      |
| IMRF Payments                    | \$ 133,597.08                 | 4/9/2026             |
| IMRF Payments (SLEP)             | \$ -                          |                      |
| Employee Medical Trust           | \$ -                          |                      |
| <b>Total Cash Disbursements:</b> | <b><u>\$ 3,963,686.85</u></b> |                      |

\* Multiple transfers processed on and/or before date shown

\*\* See attached report

Adopted by the City Council of Des Plaines

This Fourth Day of May 2026

Ayes \_\_\_\_\_ Nays \_\_\_\_\_ Absent \_\_\_\_\_

---

Dominik Bronakowski, City Clerk

---

Andrew Goczkowski, Mayor



**CITY MANAGER'S OFFICE**

1420 Miner Street  
Des Plaines, IL 60016  
P: 847.391.5488  
desplainesil.gov

**MEMORANDUM**

Date: April 23, 2026

To: Mayor Goczkowski and Aldermen of the City Council

From: Dorothy Wisniewski, City Manager *DW*  
Jeff Rogers, AICP, Director of Community and Economic Development *JR*  
Tim Watkins, Director of Public Works and Engineering

Cc: Peter Friedman, Elrod Friedman, City Attorney for City of Des Plaines

Subject: Consideration of a Resolution approving a Purchase and Sale Agreement for the former Lattof YMCA building at 300 E. Northwest Highway

---

**Issue:** For the City Council to consider the purchase and sale agreement for the former Latoff YMCA building at 300 E. Northwest Highway.

**Analysis:** The City Council directed the City Manager to negotiate the purchase of the former Lattof YMCA. The site includes a series of interconnected buildings on 4.27 acres at 300 E. Northwest Highway. A third-party appraisal by Marous & Company valued it at \$2.2 million. The City Manager negotiated a price of \$1,850,000 with Council authority.

The site has served Des Plaines since 1961 as a key recreation hub offering health, fitness, sports leagues, and other programs for all ages. After its 2020 COVID-caused closure, private ownership limited public access. A proposed Purchase and Sale Agreement now enables renewed community investment through redevelopment.

**Recommendation:** In accordance with the City Council's direction, we recommend approval of the associated Purchase and Sale Agreement for 300 E. Northwest Highway.

**Attachments:**

- Resolution R-115 -26
- Exhibit A – Legal Description
- Exhibit B – Purchase & Sale Agreement

**CITY OF DES PLAINES**

**RESOLUTION R - 115 - 26**

**A RESOLUTION AUTHORIZING THE PURCHASE OF  
PROPERTY LOCATED AT 300 EAST NORTHWEST  
HIGHWAY, DES PLAINES, ILLINOIS.**

**WHEREAS**, Article VII, Section 10 of the 1970 Illinois Constitution authorizes the City to contract with individuals, associations, and corporations in any manner not prohibited by law or ordinance; and

**WHEREAS**, the Board of Trustees of the Young Men’s Christian Association of Chicago, a charter entity constituted pursuant to Special Acts of the Illinois General Assembly in 1861, as amended in 1867, and operating as a non-profit organization in Illinois (“**Owner**”), is the owner of those certain parcels of property commonly known as 300 East Northwest Highway, Des Plaines, Illinois, and legally described in **Exhibit A** attached to, and by this reference made a part of, this Resolution (“**Property**”); and

**WHEREAS**, the City desires to purchase the Property for the purchase price of \$1,850,000.00 (“**Purchase Price**”), which purchase is conditioned on the fulfillment of all terms, conditions, and purposes set forth in that certain Purchase and Sale Agreement by and between the City and the Owner (“**Agreement**”); and

**WHEREAS**, the City Council has determined that it is in the best interest of the City to enter into the Agreement with the Owner for the purchase of the Property;

**NOW, THEREFORE, BE IT RESOLVED** by the City Council of the City of Des Plaines, Cook County, Illinois, in the exercise of its home rule powers, as follows:

**SECTION 1: RECITALS.** The foregoing recitals are incorporated into, and made a part of, this Resolution as findings of the City Council.

**SECTION 2: APPROVAL OF AGREEMENT.** The City Council hereby approves the Agreement with the Owner for the purchase of the Property for the Purchase Price in substantially the form attached to this Resolution as **Exhibit B**, and in a final form approved by the City Manager and General Counsel.

**SECTION 3: AUTHORIZATION TO EXECUTE DOCUMENTS.** The City Council hereby authorizes and directs the City Manager to execute, on behalf of the City, the final Agreement and the Mayor, City Manager, City Clerk, and City Attorney, and such other officials as may be necessary, are hereby authorized to execute all agreements, legal instruments and other documents required to effectuate the intent of this resolution.

**SECTION 4: EFFECTIVE DATE.** This Resolution shall be in full force and effect from and after its passage and approval according to law.

**[SIGNATURE PAGE FOLLOWS]**

**PASSED** this \_\_\_\_ day of \_\_\_\_\_, 2026

**APPROVED** this \_\_\_\_ day of \_\_\_\_\_, 2026

**VOTE:** AYES \_\_\_\_ NAYS \_\_\_\_ ABSENT \_\_\_\_

---

**MAYOR**

ATTEST:

Approved as to form:

---

**CITY CLERK**

---

**Peter M. Friedman, General Counsel**

## EXHIBIT A

### LEGAL DESCRIPTION OF PROPERTY

#### PARCEL 1:

THAT PORTION OF LOT 'C' OF CUMBERLAND VILLAGE, UNIT NUMBER 1, BEING A SUBDIVISION OF PART OF THE SOUTH WEST FRACTIONAL 1/4 OF FRACTIONAL SECTION 7, TOWNSHIP 41 NORTH, RANGE 12 EAST OF THE THIRD PRINCIPAL MERIDIAN, DESCRIBED AS FOLLOWS: COMMENCING AT THE INTERSECTION OF THE NORTHERLY LINE OF UNITED STATES ROUTE 14 (COMMONLY KNOWN AS THE NORTHWEST HIGHWAY) WITH A LINE, 510.22 FEET WEST OF AND PARALLEL WITH THE EAST LINE OF SAID SOUTH WEST FRACTIONAL 1/4 OF SECTION 7, TOWNSHIP 41 NORTH, RANGE 12 EAST OF THE THIRD PRINCIPAL MERIDIAN, AS MEASURED AT RIGHT ANGLES TO SAID EAST LINE; THENCE NORTH ALONG SAID PARALLEL LINE (AT AN ANGLE OF 59 DEGREES 23 MINUTES 10 SECONDS WITH THE NORTH LINE OF SAID ROUTE 14) 400.84 FEET; THENCE WEST AT AN ANGLE OF 90 DEGREES WITH THE LAST DESCRIBED COURSE, A DISTANCE OF 166.85 FEET, MORE OR LESS, TO A POINT, 260 FEET NORTHEASTERLY OF THE NORTHERLY LINE OF SAID UNITED STATES ROUTE 14 AS MEASURED AT RIGHT ANGLES TO SAID NORTHERLY LINE; THENCE NORTHWESTERLY PARALLEL TO SAID NORTHERLY LINE AND 260 FEET NORTHEASTERLY THEREOF (AS MEASURED AT RIGHT ANGLES THERETO), A DISTANCE OF 253.95 FEET; THENCE SOUTHWESTERLY AT RIGHT ANGLES TO THE LAST DESCRIBED COURSE, 260 FEET TO A POINT ON THE NORTHERLY LINE OF SAID UNITED STATES ROUTE 14, 601.67 FEET NORTHWESTERLY FROM THE POINT OF BEGINNING; THENCE SOUTHEASTERLY 601.67 FEET ALONG SAID NORTHERLY LINE TO THE POINT OF BEGINNING, IN COOK COUNTY, ILLINOIS.

NOTE: PARCEL 1 OF THE LAND IS ALSO KNOWN AS TRACT 'D' OF CUMBERLAND VILLAGE UNIT NUMBER 2 REGISTERED JUNE 1, 1956 N BOOK 48 OF TORRENS PLATS PAGE 30 AS DOCUMENT NUMBER 1673761.

ALSO;

#### PARCEL 2:

LOT 26 AND LOT 27 AND ALL OF VACATED KENTON ROAD LYING WESTERLY OF CAMBRIDGE AVENUE BETWEEN LOTS 26 AND 27 IN H.M. CORNELL & CO'S CUMBERLAND WEST, BEING A SUBDIVISION OF PART OF THE EAST HALF OF THE SOUTHWEST FRACTIONAL QUARTER OF FRACTIONAL SECTION 7, TOWNSHIP 41 NORTH, RANGE 12 EAST OF THE THIRD PRINCIPAL MERIDIAN, IN COOK COUNTY, ILLINOIS, ACCORDING TO THE PLAT THEREOF REGISTERED IN THE OFFICE OF THE REGISTRAR OF TITLES OF COOK COUNTY, ILLINOIS ON MARCH 4, 1955 AS DOCUMENT 1579383.

Property Address: 300 East Northwest Highway, Des Plaines, Illinois

PINs: 09-07-310-005; 09-07-310-020; and 09-07-311-001

**PURCHASE AND SALE AGREEMENT**  
(300 East Northwest Highway, Des Plaines, Illinois)

**THIS PURCHASE AND SALE AGREEMENT (“Agreement”)** is made as of the Effective Date (as defined in Section 25 below) by and between **THE BOARD OF TRUSTEES OF THE YOUNG MEN’S CHRISTIAN ASSOCIATION OF CHICAGO**, a charter entity constituted pursuant to Special Acts of the Illinois General Assembly in 1861, as amended in 1867, and operating as a non-profit organization in Illinois (“**Seller**”), and the **CITY OF DES PLAINES**, an Illinois home rule corporation (“**Buyer**”).

**A G R E E M E N T :**

1. **BUYER AND SELLER ACKNOWLEDGE AND AGREE THAT BUYER IS A GOVERNMENTAL ENTITY AND ALTHOUGH THIS AGREEMENT MAY BE EXECUTED BY THE CITY MANAGER OF BUYER, THIS AGREEMENT IS SUBJECT TO, AND CONTINGENT ON, THE APPROVAL OF, AND IS NOT ENFORCEABLE UNLESS APPROVED AT AN OPEN MEETING BY, THE CORPORATE AUTHORITIES OF BUYER (“CORPORATE AUTHORITIES”). IN THE EVENT THIS CONTINGENCY IS NOT SATISFIED ON OR BEFORE SEPTEMBER 30, 2026, THIS AGREEMENT WILL AUTOMATICALLY TERMINATE AND THE PARTIES WILL HAVE NO FURTHER RIGHTS OR OBLIGATIONS HEREUNDER, EXCEPT FOR THOSE THAT EXPRESSLY SURVIVE ANY SUCH TERMINATION.**

2. **PURCHASE AND SALE OF PROPERTY.** Seller, whose identity will be updated to conform with the owner of record set forth in the Title Commitment (as defined in Section 7 below), if the identity of Seller differs from the owner of record in the Title Commitment, agrees to sell to Buyer, and Buyer agrees to purchase from Seller, upon the terms and conditions set forth in this Agreement, fee simple title to certain real property commonly known as 300 East Northwest Highway, Des Plaines, Illinois (PIN: 09-07-310-005-0000; 09-07-310-020-0000; and 09-07-311-001-0000,) located in the County of Cook (“**Property**”), which Property is legally described in **EXHIBIT A** attached hereto and made a part hereof, together with (i) all privileges, rights, easements, hereditaments and appurtenances thereto belonging, (ii) all right, title and interest of Seller in and to any streets, alleys, passages, common areas, amenities and other rights of way included therein or adjacent thereto, (iii) all buildings, structures and improvements located upon the Property including, without limitation, Seller’s interest in all systems, facilities, fixtures, machinery, equipment and conduits to provide fire protection, security, heat, exhaust, ventilation, air conditioning, electrical power, light, plumbing, refrigeration, gas, sewer and water thereto, and (iv) Seller’s interest in all tangible personal property located on the Property and used in connection with operation and maintenance of the improvements. The legal description will be updated to conform with the legal description from the Survey (as defined in Section 8 below), if the legal description from the Survey differs from that in **EXHIBIT A**.

3. **PURCHASE PRICE.** The purchase price for the purchase of the Property by Buyer is One Million Eight Hundred Fifty Thousand and No/100 Dollars (\$1,850,000.00) (“**Purchase Price**”). The Purchase Price will be paid by Buyer to Seller on the Closing Date (as defined in Section 5 below) after crediting the Earnest Money and subject to the prorations and adjustments set forth herein.

4. **EARNEST MONEY.** Within ten (10) business days after the Agreement is approved by the Corporate Authorities of Buyer as set forth in Section 1 above, Buyer will deposit Fifteen Thousand and No/100 Dollars (\$15,000.00) (“**Earnest Money**”) with the Title Company (as

defined in Section 5 below), pursuant to mutually acceptable strict joint order escrow instructions. Within one (1) business day after the expiration of both the Due Diligence Period and the deadline following the Objection Letter (as provided in Section 6.A. and Section 7, and provided that this Agreement is not sooner terminated in accordance with Section 6.A. or Section 7, the Earnest Money, and if applicable, Extended Due Diligence Period Earnest Money (as defined below), shall be nonrefundable but shall be applied to the Purchase Price in the event that the Closing occurs. At the Closing of the transaction, the Earnest Money and if applicable, Extended Due Diligence Period Earnest Money will be applied towards the Purchase Price.

5. **CLOSING AND POSSESSION.** The closing ("**Closing**") of the contemplated purchase and sale of the Property will take place remotely through a deed and money escrow ("**Escrow**") at the office of Old Republic Title Insurance Company, 20 S. Clark Street, Chicago, Illinois 60603 ("**Title Company**"), or at such other time and place as mutually agreed to by the parties. The parties need not physically attend the Closing.

A. **Closing Date.** The Closing will take place on or before 30 days following the expiration of the Due Diligence Period (defined below) ("**Closing Date**") unless extended pursuant to Buyer's Extended Due Diligence Period (defined below) for an additional thirty (30) calendar days or at such other time as mutually agreed to by the parties.

6. **BUYER'S DUE DILIGENCE PERIOD**

A. **Buyer's Due Diligence Period.** During the period that begins on the Effective Date and ends 30 days following the Effective Date (the "**Due Diligence Period**"), Buyer may enter upon the Property at all reasonable times to conduct such investigations, inspections, reviews, and analyses of or with respect to the Property as Buyer desires ("**Inspection Activities**"). Buyer agrees to coordinate the Inspection Activities with Seller. The Inspection Activities include, but are not limited to, examining the Seller Deliveries (as hereinafter defined), title to the Property, and conducting such marketing, economic, feasibility, and physical inspections, including environmental testing, such as Phase 1 Environmental Site Assessment and, if necessary, Phase 2 Environmental Site Assessment, of and on the Property as Buyer, in its sole discretion, deems necessary or prudent to determine the suitability of the Property.

Within three (3) business days after the Effective Date, Seller will deliver to Buyer copies of all of the following pertaining to the Property in Seller's possession or control: (i) all environmental studies and reports, as-built drawings and architectural and civil plans and specifications, (ii) a copy of the existing survey of the Property, (iii) a copy of the existing title policy, current title commitment and title exception documents, (iv) any and all licenses, permits, entitlements or other agreements affecting use and occupancy of the Property, if applicable, (v) insurance bills for the current and prior two years, (vi) a list of all personal property, (vii) all contracts and services agreements binding on the Property (viii) relevant unrecorded documents and (ix) all transferable warranties of any kind for labor and material related to construction on the Property (collectively "**Seller Deliveries**").

Buyer shall have the right to extend the Due Diligence Period ("**Extended Due Diligence Period**") for one (1) additional thirty (30) calendar day period if, prior to the expiration of the Due Diligence Period, Buyer delivers written notice of the Extended Due Diligence Period to Seller. Should Buyer exercise this option and enter into the Extended Due Diligence Period, then Buyer shall also, concurrent with providing Seller with the Extended Due Diligence Period election notice, deposit an additional Ten Thousand and No/100 Dollars (\$10,000.00) (the "**Extended Due Diligence**").

**Period Earnest Money**) with the Title Company. Buyer will have until the end of the Due Diligence Period or Extended Due Diligence Period, if applicable, in which to make such investigations and studies with respect to the Property as Buyer deems appropriate, and to deliver written notice to Seller terminating this Agreement if Buyer is not, for any reason or no reason, satisfied with the Property. If Buyer does so deliver notice to Seller terminating this Agreement, this Agreement will terminate and, provided Buyer is not then in default under this Agreement, the Earnest Money will be refunded to Buyer by Title Company, and the parties will have no further rights or obligations hereunder, except for those that expressly survive such termination.

**B. Physical Due Diligence.** Commencing upon the Effective Date and continuing until the Closing, Buyer shall have reasonable access to the Property at all reasonable times during normal business hours for the purpose of conducting tests, including surveys and architectural, engineering, geotechnical, and environmental inspections and tests, provided that:

i. Buyer must give Seller at least twenty-four (24) hours' prior written notice to Seller (via email to Basil Fitzsimons ([bfitzsimons@ymcachicago.org](mailto:bfitzsimons@ymcachicago.org)), with copy to [jshlensky@ymcachicago.org](mailto:jshlensky@ymcachicago.org) and [legal@ymcachicago.org](mailto:legal@ymcachicago.org) or as otherwise instructed) of any such inspection or test;

ii. Prior to performing any inspection or test, Buyer must deliver a Certificate of Insurance to Seller evidencing that Buyer and its contractors, agents and representatives have in place (and Buyer and its contractors, agents, and representatives shall maintain during the pendency of this Agreement) (a) commercial general liability insurance with limits of at least One Million Dollars (\$1,000,000.00) per occurrence and at least Five Million Dollars (\$5,000,000.00) in the aggregate for bodily injury or death and property damage insurance including coverage for contractual liability and personal and advertising injury with respect to Buyer's obligations hereunder, (b) commercial auto liability policy in the amount of at least One Million Dollars (\$1,000,000.00) and (c) workers' compensation and employers' liability insurance with limits of at least Five Hundred Thousand Dollars (\$500,000.00) each accident and Five Hundred Thousand Dollars (\$500,000.00) policy limit, all covering any accident arising in connection with the presence of Buyer, its contractors, agents and representatives on the Property, which insurance, except for workers' compensation and employers' liability, shall (x) name as additional insureds thereunder Seller and such other parties holding insurable interests as Seller may designate and (y) be written by a reputable insurance company having a rating of at least "A-VII" by Best's Rating Guide (or a comparable rating by a successor rating service), and (z) otherwise be subject to Seller's prior approval, which shall not be unreasonable withheld, conditioned or delayed;

iii. In conducting any inspections, investigations or tests of the Property and/or information relating thereto, Buyer and its agents and representatives shall use commercially reasonable efforts, but will not be in default unless given notice and a commercially reasonable period to cure, for the following: (a) not interfere with the operation and maintenance of the Property; (b) not damage any part of the Property; (c) not physically injure or otherwise cause bodily harm to Seller or its agents, guests, invitees, contractors and employees; (d) comply with all applicable laws; (e) promptly pay when due the costs of all tests, investigations, and examinations done with regard to the Property; (f) not permit any liens to attach to the Real Property by reason of the exercise of its rights hereunder; (g) repair any damage to the Real Property resulting directly or indirectly from any such inspection or tests; and (h) not reveal or disclose prior to Closing any information obtained during its inspection of or obtaining facts concerning the Property

and information relating thereto to anyone other than the Permitted Outside Parties (those persons who are responsible for investigating the Property in connection with Buyer's acquisition of the Property, the City and those consultants on behalf of the City and/or who may provide or assist Buyer with financing for purchase of the Property, and who have agreed to preserve the confidentiality of such information), except for Buyer's disclosure obligations as a municipal entity. All of Buyer's repair obligations in this Agreement are limited to restoration of the Property to the existing condition immediately prior to the Inspection Activities. Buyer's obligations under this Section shall survive the termination of this Agreement and shall survive the Closing for twelve (12) months.

**C. Proprietary Information; Confidentiality.** Buyer will use commercially reasonable efforts and coordinate with Seller to limit the disclosure of proprietary information to the extent Buyer is permitted to limit such disclosure as a municipal entity.

**D. No Representation of Warranty by Seller.** Except for Seller's representations set forth in this Agreement, Buyer shall rely solely upon its own investigation with respect to the Property, including the conditions or requirements for the development, sale or occupancy of the Property, the Property's physical, environmental or economic condition, compliance or lack of compliance with any ordinance, order, permit or regulation, conditions and requirements for the development of the Property or any other attribute or matter relating thereto. Buyer further acknowledges that some if not all of such information may have been prepared by third parties other than Seller. Seller expressly disclaims any and all liability for representations or warranties, express or implied, statements of fact and other matters contained in such information, whatever its origin, or for omissions from any such information, or in any other written or oral communications transmitted or made available to Buyer, except as provided for elsewhere in this Agreement.

**E. Buyer's Agreement to Indemnify.** Buyer will indemnify Seller for any damage caused during the Inspection Activities and will repair any damage to the state prior to the Inspection Activities if requested by Seller.

7. **TITLE INSURANCE.** At Seller's cost, Buyer will obtain and Seller will cooperate with Buyer in obtaining a title commitment issued by the Title Company, in the amount of the Purchase Price ("**Title Commitment**"), together with access to the copies of all underlying title documents listed in the Title Commitment ("**Underlying Title Documents**"), subject only to those matters described in **EXHIBIT B**, attached hereto and made a part hereof ("**Permitted Exceptions**"). If the Title Commitment, Underlying Title Documents or the Survey disclose exceptions to title, which are not acceptable to Buyer ("**Unpermitted Exceptions**"), Buyer may object to the Unpermitted Exceptions at any time prior to Closing. Buyer will provide Seller with an objection letter ("**Objection Letter**") listing the Unpermitted Exceptions, which are not acceptable to Buyer. Seller will have until the Closing to have the Unpermitted Exceptions removed from the Title Commitment or to cure such Unpermitted Exceptions or to have the Title Company commit to insure against loss or damage that may be occasioned by such Unpermitted Exceptions, as evidenced by Buyer's receipt of a proforma title policy ("**Proforma Title Policy**") reflecting the Title Company's commitment to insure the Unpermitted Exceptions. If Seller fails to have the Unpermitted Exceptions removed or, in the alternative, to obtain a Title Commitment insuring the Unpermitted Exceptions within the specified time, Buyer may elect to either (i) terminate this Agreement and receive the Earnest Money and this Agreement will become null and void without further action of the parties, or (ii) upon notice to Seller before the Closing, take title as it then is with the right to deduct from the Purchase Price any liens or encumbrances of a definite or ascertainable amount which are listed in the Title Commitment. The Proforma Title Policy will be

conclusive evidence of good title as shown therein as to all matters insured by the Title Company, subject only to the Permitted Exceptions.

8. **SURVEY**. After the Effective Date, at Buyer's cost, Buyer may obtain a current ALTA/NSPS survey of the Property ("**Survey**"). Seller to contact JULIE for Dig No. and completion date and all utilities to be marked prior to surveyor's field work so that there is evidence of all utilities.

9. **DEED**. At Closing, Seller will convey fee simple title to the Property to Buyer by a recordable Special Warranty Deed ("**Deed**") subject only to the Permitted Exceptions.

10. **CLOSING DOCUMENTS**. On the Closing Date, the obligations of Buyer and Seller will be as follows:

A. Seller will deliver or cause to be delivered to the Title Company:

- i. the original executed and properly notarized Deed and with applicable exemption language;
- ii. the original executed and properly notarized affidavit of title;
- iii. the original executed and properly notarized bill of sale;
- iv. the original executed and properly notarized Foreign Investment in Real Property Tax Act affidavit;
- v. a counterpart of the closing statement;
- vi. all keys and other access to the Property; and
- vii. such other standard closing documents or other documentation as is required by applicable law or the Title Company to effectuate the transaction contemplated hereby, including, without limitation, an ALTA Statement and GAP Undertaking or such other documentation as is reasonably required by the Buyer or the Title Company to issue Buyer its owners title insurance policy in accordance with the Proforma Title Policy.

B. Buyer will deliver or cause to be delivered to the Title Company:

- i. the balance of the Purchase Price, plus or minus prorations;
- ii. counterpart of the closing statement; and
- iii. Buyer-executed bill of sale, if signature is required;
- iv. such other standard closing documents or other documentation as is required by applicable law or the Title Company to effectuate the transaction contemplated herein, including but not limited to conveyancing or transfer tax forms as are required to be delivered or signed by Buyer by applicable state and local law in connection with the conveyance of the Property.

C. Buyer will prepare the Closing documents, each of which will be in form approved by Seller.

D. The parties will jointly deposit fully executed Closing escrow instructions, State of Illinois, Cook County, and City of Des Plaines (if required) transfer declarations ("**Transfer Declarations**").

11. **POSSESSION**. If the Closing occurs, possession of the Property will be finally and fully delivered to Buyer on the Closing Date, free and clear of any other parties. Any leases affecting the Property, if any, must be terminated prior to Closing. All loose refuse and personal property that is not to be conveyed to Buyer will be removed from the Property at Seller's expense prior to delivery of possession. Buyer will have the right to inspect the Property prior to Closing to verify that the Property is in broom clean condition and substantially the same condition as of Effective Date, normal wear and tear excepted.

12. **PRORATIONS/CLOSING COSTS**. At Closing, the following adjustments and prorations will be computed as of the Closing Date and the balance of the Purchase Price will be adjusted to reflect such prorations. All prorations will be based on a 365-day year, with Seller having the day of the Closing.

A. **Real Estate Taxes**. General real estate taxes for 2025 will be paid by Seller at Closing and subsequent years, special assessments and all other public or governmental charges against the Property, if any, which are or may be payable on an annual basis (including charges, assessments, liens or encumbrances for sewer, water, drainage or other public improvements completed or commenced on or prior to the Closing Date) will be adjusted and apportioned as of the Closing Date. If the exact amount of general real estate taxes is not known at Closing, the proration will be based on 110% per year of the most recent full year tax bill, and will be conclusive, with no subsequent adjustment.

B. **Closing Costs**. Buyer will pay the costs charged by the Title Company for any title endorsements requested by Buyer, costs of recording the Deed, and Survey. The parties shall equally split the cost of any and all escrow fees and costs, including those charged for holding the Deposit or conducting the Closing. Seller will pay the costs associated with the Title Commitment and the pro forma title policy with extended coverage. Buyer and Seller will each pay their respective attorney's fees. All other charges and fees customarily prorated and adjusted in similar transactions will be prorated as of Closing Date. In the event that accurate prorations and other adjustments cannot be made at Closing because current bills or statements are not obtainable (as, for example, all water, sewer, gas and utility bills), the parties will prorate on the best available information. Final readings and final billings for utilities will be taken as of the date of Closing except for a water bill which may be taken up to two (2) days before the Closing Date.

13. **CONVEYANCE TAXES**. The parties acknowledge that, as Buyer is a governmental entity, this transaction is exempt from any State and County real estate transfer tax pursuant to 35 ILCS 200/31-45(b). Seller will furnish completed Real Estate Transfer Declarations signed by Seller or Seller's agent in the form required pursuant to the Real Estate Transfer Tax Act of the State of Illinois, in addition to any applicable City Transfer Declaration and transfer stamps.

14. **COVENANTS, REPRESENTATIONS, DISCLAIMERS, AND WARRANTIES**. The covenants, representations, disclaimers and warranties contained in this Section will be deemed remade as of the Closing Date and will survive the Closing for a period of twelve (12) months and will be deemed to have been relied upon by Buyer in consummating this transaction, notwithstanding any investigation Buyer may have made with respect thereto, or any information developed by or made available to Buyer prior to the Closing and consummation of this transaction. Seller covenants, represents and warrants to Buyer as to the following matters, each

of which is so warranted to be true and correct as of the Effective Date and also on the Closing Date. Furthermore, except as expressly set forth in this Agreement, it is understood and agreed that Seller and Seller's agents, representatives, beneficiaries, trustees and heirs (collectively, with Seller, the "**Seller Parties**") have not at any time made and are not now making, and they specifically disclaim, any warranties, representations or guaranties of any kind or character, express or implied, with respect to the Property, except as otherwise stated in this Agreement.

A. **Sale "As Is, Where Is"**. Buyer acknowledges and agrees that upon Closing, Seller shall sell and convey to Buyer and Buyer shall accept the Property "AS IS, WHERE IS, WITH ALL FAULTS". Except as expressly set forth in this Agreement, Buyer has not relied and will not rely on, and the Seller Parties have not made and are not liable for or bound by, any express or implied warranties, guarantees, statements, representations or information pertaining to the Property or relating thereto (including, specifically, information packages distributed with respect to the Property) made or furnished by Seller, any of the other Seller Parties or any property manager, real estate broker (including, but not limited to, Broker), agent or third party representing or purporting to represent Seller, to whomever made or given, directly or indirectly, orally or in writing, except as otherwise stated in this Agreement.

B. **Buyer's Investigation**. Buyer may conduct such inspections and investigations of the Property as Buyer deems necessary, including, but not limited to, any requirements or conditions for the development, sale, use or occupancy of the Property and the physical and environmental conditions thereof, and shall rely upon same. Buyer acknowledges that Seller has afforded Buyer a full opportunity to conduct such investigations of the Property as Buyer deemed necessary to satisfy itself as to such requirements and conditions, the condition of the Property and the existence or non-existence with respect to any Hazardous Materials on or discharged from the Property, and, Buyer will rely solely upon same and not upon any information provided by or on behalf of Seller or any other Seller Parties with respect thereto, other than such representations, warranties and covenants of Seller as are expressly set forth in this Agreement. Upon Closing, Buyer shall assume the risk that adverse matters, including, but not limited to, adverse physical or construction defects or adverse environmental, health or safety conditions, may not have been revealed by Buyer's inspections and investigations, except as otherwise stated in this Agreement.

**C. BUYER'S ACKNOWLEDGEMENT.** BUYER ACKNOWLEDGES AND AGREES THAT, EXCEPT AS SPECIFICALLY SET FORTH IN THIS AGREEMENT, THE PROPERTY WILL BE PURCHASED BY BUYER AND SOLD AND DELIVERED BY SELLER IN AN "AS IS" CONDITION AND ON A "WHERE-IS" BASIS "WITH ALL FAULTS INCLUDING, BUT NOT LIMITED TO, BOTH LATENT AND PATENT DEFECTS." BUYER ACKNOWLEDGES AND AGREES THAT, EXCEPT AS EXPRESSLY SET FORTH IN THIS AGREEMENT, NO WARRANTIES, EXPRESS, IMPLIED OR STATUTORY, OF ANY KIND WHATSOEVER, HAVE BEEN, ARE OR AT ANY TIME WILL BE MADE BY THE SELLER PARTIES OR ANY OTHER PERSON, AND BUYER WAIVES ALL SUCH WARRANTIES, OTHER THAN AS SET FORTH EXPRESSLY IN THIS AGREEMENT, INCLUDING WITH RESPECT TO THE CONDITION (PHYSICAL OR OTHERWISE) AND USE OF THE PROPERTY INCLUDING, BUT NOT LIMITED TO, (i) WARRANTIES OF MERCHANTABILITY OR FITNESS FOR A PARTICULAR PURPOSE, (ii) WARRANTIES WITH RESPECT TO THE CONDITION OF THE PROPERTY, ITS COMPLIANCE WITH ANY ZONING OR OTHER RULES, REGULATIONS, LAWS OR STATUTES APPLICABLE TO THE PROPERTY, (iii) WARRANTIES WITH RESPECT TO THE USES PERMITTED ON, THE DEVELOPMENT REQUIREMENTS OR CONDITIONS FOR, OR

ANY OTHER MATTER OR THING RELATING TO THE PROPERTY OR ANY PORTION THEREOF, INCLUDING SOIL, COMPACTION, DRAINAGE, SEISMIC, HAZARDOUS MATERIALS, COMPLIANCE WITH ENVIRONMENTAL REQUIREMENTS, UTILITIES, ACCESS, COMPLIANCE WITH RENT CONTROL ORDINANCES, AND THE ECONOMIC OR OTHER RETURN THAT MAY BE DERIVED FROM OWNERSHIP, DEVELOPMENT, IMPROVEMENT OR USE OF THE PROPERTY, OR (iv) WARRANTIES WITH RESPECT TO ANY IMPROVEMENTS TO THE PROPERTY OR ANY WORK THERETO. BUYER ALSO ACKNOWLEDGES THAT SOME DEFECTS MAY NOT BECOME APPARENT PRIOR TO THE CLOSING DATE AND HEREBY RELEASES THE SELLER PARTIES FROM BLAME AND ALL LIABILITY FOR SUCH "LATENT DEFECTS." EXCEPT AS OTHERWISE PROVIDED IN THIS AGREEMENT, BUYER HEREBY COVENANTS NOT TO BRING ANY ACTION AGAINST ANY OF THE SELLER PARTIES BASED ON ANY OF THESE CLAIMS, EXCEPT AS OTHERWISE PROVIDED IN THIS AGREEMENT.

**D. Seller Parties Released from Liability.**

Except as otherwise set forth in this Agreement, Buyer acknowledges that it will have the opportunity to inspect the Property during the Due Diligence Period, and during such period, observe its physical characteristics and existing conditions and the opportunity to conduct such investigation and study on and off the Property and adjacent areas as Buyer deems necessary, and as of the Closing Buyer hereby FOREVER RELEASES AND DISCHARGES the Seller Parties from all responsibility and liability (including civil liability) regarding the condition, valuation, salability or utility of the Property, or its suitability for any purpose whatsoever, including liabilities under the Comprehensive Environmental Response, Compensation and Liability Act Of 1980 (42 U.S.C. Sections 9601 et seq.), as amended ("**CERCLA**"), and from all other federal, state and local laws, rules, regulations or ordinances that might impose liability regarding the development, use, sale, occupancy, condition, valuation, salability or utility of the Property, or its suitability for any purpose whatsoever (including, but not limited to, with respect to the presence in the soil, air, structures and surface and subsurface waters, of Hazardous Materials or other materials or substances that have been or may in the future be determined to be toxic, hazardous, undesirable or subject to regulation and that may need to be specially treated, handled and/or removed from the Property under current or future federal, state and local laws, regulations or guidelines, and any structural and geologic conditions, subsurface soil and water conditions and solid and hazardous waste and Hazardous Materials on, under, adjacent to or otherwise affecting the Property). Except as otherwise set forth in this Agreement, Buyer further hereby WAIVES (and by Closing this transaction will be deemed to have WAIVED) any and all objections and complaints (including, but not limited to, federal, state and local statutory and common law based actions, and any private right of action under any federal, state or local laws, regulations or guidelines to which the Property is or may be subject (including, but not limited to, CERCLA) concerning the development, use, sale, occupancy, the physical characteristics and any existing conditions of the Property, whether arising before or after the Effective Date. Except as otherwise set forth in this Agreement, Buyer further hereby assumes the risk of changes in applicable laws and regulations relating to past, present and future environmental conditions on the Property and the risk that adverse physical characteristics and conditions, including, without limitation, the presence of Hazardous Materials or other contaminants, may not have been revealed by its investigation.

**E. Possession.** Possession of the Property has been with Seller prior to the Effective Date. There are no agreements, understandings, or other commitments granting third parties any right to the use or possession of the Property,

**F. Title Matters.** Seller has good and marketable fee simple title to the Property, subject only to the Permitted Exceptions.

**G. Violations of Zoning and Other Laws.** No written notice from any governmental agency relating to the Property alleging any violations of any statute, ordinance, regulation or code has been received.

**H. Pending and Threatened Litigation.** There are no action or proceeding pending, or to Seller's actual knowledge, threatened matters of litigation, administrative action or examination, claim or demand whatsoever relating to the Property against Seller which challenges or impairs Seller's ability to execute or perform its obligations under this Agreement or which could result in a lien, charge, encumbrance or judgment against any part of or any interest in the Property.

**I. Eminent Domain.** There is no pending or contemplated eminent domain, condemnation or other governmental taking of the Property or any part thereof by a governmental agency.

**J. Access to Property Utilities.** No fact or condition exists which would result in the termination or impairment of access to the Property or which could result in discontinuation of presently available or otherwise necessary sewer, water, electric, gas, or other utilities or services.

**K. Authority of Signatories; No Breach of Other Agreements.** The execution, delivery of and performance under this Agreement by Seller is pursuant to authority validly and duly conferred upon Seller and the signatories hereto. The consummation of the transaction herein contemplated and the compliance by Seller with the terms of this Agreement do not and will not conflict with or result in a breach of any of the terms or provisions of, or constitute a default under, any agreement, arrangement, understanding, accord, document or instruction by which Seller or the Property are bound; and will not and does not, to the knowledge of Seller, constitute a violation of any applicable law, rule, regulation, judgment, order or decree of, or agreement with, any governmental instrumentality or court, domestic or foreign, to which Seller or the Property are subject or bound.

**L. Executory Agreements.** Seller is not a party to, and the Property is not subject to, any contract or agreement of any kind whatsoever, written or oral, formal or informal, with respect to the sale or transfer of the Property, other than this Agreement. Buyer will not, by reason of entering into or closing under this Agreement, become subject to or bound by any agreement, contract, lease, lease amendment, license, invoice, bill, undertaking or understanding which Buyer will not have expressly and specifically previously acknowledged and agreed in writing to accept. Other than those disclosed by Seller to Buyer pursuant to this Agreement, no written leases, licenses or occupancies exist in regard to the Property and, further, that no person, corporation, entity, tenant, licensee or occupant has an option or right of first refusal to purchase, lease or use the Property, or any portion thereof.

**M. Mechanic's Liens.** As of Closing, all obligations of Seller for bills and invoices for labor and material of any kind relating to the Property will be paid in full.

**N. Governmental Obligations.** There are no unperformed material obligations relative to the Property outstanding to any governmental or quasi-governmental body or authority. Notwithstanding the above, governmental obligations to the City of Des Plaines are specifically excluded from this Section 14(N).

**O. Easements.** To the best of Seller's knowledge, the Property has no unrecorded easements or agreements that would hinder Buyer from its intended use of the Property.

**P. Environmental Matters.** To the knowledge of Seller, (a) Hazardous Substances have not been used, generated, transported, treated, stored, released, discharged or disposed of in, onto, under or from the Property in violation of any Environmental Laws; (b) no notification of release of a Hazardous Substance has been filed as to the Property, nor is the Property listed on the National Priority List promulgated pursuant to CERCLA or on any other Federal or state list of Hazardous Substance sites requiring investigation or cleanup; (c) there are no above-ground or underground tanks or any other underground storage facilities located on the Property; and (d) the Property does not contain any Hazardous Substances. "**Hazardous Substances**" means "Hazardous Material", Hazardous Substance", "Pollutant or Contaminant", and "Petroleum" and "Natural Gas Liquids", as those terms are defined or used in Section 101 of CERCLA, and any other substances regulated because of their effect or potential effect on public health or the environment, including, without limitation, PCBs, lead paint, asbestos, urea formaldehyde, retroactive materials, putrescible materials, and infectious materials. "**Environmental Laws**". shall mean any and all present and future federal, state and local law (whether under common law, statute, rule, ordinance, agreement, regulation or otherwise), requirement under any permit issued with respect thereto, and other requirements of agencies having jurisdiction thereunder relating to or dealing with the protection of health or the environment, including the Federal Insecticide, Fungicide, and Rodenticide Act, 7 U.S.C. §§ 136, et seq.; the Toxic Substances Control Act, 15 U.S.C. §§ 2601, et seq.; Federal Asbestos Hazard Emergency Response Act, 15 U.S.C. §§ 2641 et seq.; the Comprehensive Environmental Response, Compensation and Liability Act of 1980, 42 U.S.C. §§ 9601, et seq.; the Resource Conservation and Recovery Act, 42 U.S.C. §§ 6901 et seq.; the Federal Water Pollution Prevention and Control Act, 33 U.S.C. §§ 1251 et seq.; the Hazardous Materials Transportation Act, 49 U.S.C. §§ 1801, et seq.; the Solid Waste Disposal Act, 42 U.S.C. §§ 6901, et seq.; the Federal Water Pollution Control Act, 33 U.S.C. §§ 1321; and 42 U.S.C. §§ 7401 et seq.; all as amended to the date hereof.

**Q. Section 1445 Withholding.** Seller represents that it is not a "foreign person" as defined in Section 1445 of the Internal Revenue Code and is, therefore, exempt from the withholding requirements of said Section. At Closing, Seller will furnish Buyer with a Non-Foreign Affidavit as set forth in said Section 1445.

**R. No Bankruptcy.** Seller has not filed any petition in bankruptcy or made any assignment for the benefit of creditors, or filed any petition seeking reorganization or arrangement or other action under Federal or State bankruptcy laws wherein Seller is named a debtor, and Seller has not received written notice of any such petition or action filed or initiated against it.

**S. Assessments; Tax Appeals.** Within the three (3) year period immediately preceding the Effective Date (and at Closing, within the three (3) year period immediately preceding the Closing Date), Seller has received no written notice from any governmental authority of any special or other assessments for public improvements or otherwise now affecting the Property nor does Seller have knowledge of any pending or threatened special or other assessments affecting the Property or any tax abatements or exemptions affecting the Property. To the best of Seller's knowledge, as of the Effective Date, there are no pending certiorari or other proceeding to determine or appeal the assessed value of the Property. There are no proceedings pending for the reduction of the assessed valuation of the Property, or any portion thereof. Seller shall not commence or settle any such proceeding except upon the advice of tax counsel and with the prior written consent of Buyer, which consent shall not be unreasonably withheld or delayed. Any settlement and/or award made in connection with any such proceeding shall be prorated

between the parties based on the Closing Date, and such obligation to prorate any such settlement and/or award shall survive Closing.

**T. Intentionally Omitted.**

**U. Purchase Rights.** Seller has not granted to any person or entity any option or other right to purchase, sell or lease all or any portion of the Property (other than this Agreement) which option or other right is currently in effect, and to Seller's knowledge, no person or entity has any option or other right to purchase the Property.

**V. Employees.** There are no employees of Seller in respect to the operation of the Property for which Buyer shall be responsible or liable for after the Closing. Seller is not a party to or, to Seller's knowledge, bound by any collective bargaining agreements or other agreements with a union that are binding on the operation of the Property. There are no labor or other disputes, litigation or proceedings pending or threatened against or related to Seller, the Property or the operation thereof, nor, to Seller's knowledge, does any basis exist for any such action.

**W. Association.** The Property is not subject to any property owner, condominium or homeowner association.

**X. Operational Systems.** Seller represents that the heating, plumbing, electrical, central cooling, ventilating systems, appliances, and fixtures on the Property are in working order as of the Effective Date and the Closing Date.

Seller hereby indemnifies and holds Buyer harmless against all losses, damages, liabilities, costs, expenses (including reasonable attorneys' fees) and charges which Buyer may incur or to which Buyer may become subject as a direct or indirect consequence of such breach of the above representations or warranties made hereunder, including all incidental and consequential damages which are incurred within twelve (12) months of the Closing.

The terms and conditions of this Section 14 shall expressly survive the Closing and shall not merge with the provisions of any closing documents. Buyer acknowledges and agrees that these disclaimers and other agreements set forth herein are an integral part of this Agreement and that Seller would not have agreed to sell the Property to Buyer for the Purchase Price without the disclaimers and other agreements set forth above.

15. **CONDEMNATION OR CASUALTY PRIOR TO CLOSING.** If prior to Closing the Property is destroyed or materially damaged by fire or other casualty, or the Property is taken by condemnation, then Buyer will have the option of either terminating this Agreement (and receiving a refund of Earnest Money) or accepting the Property as damaged or destroyed, together with the proceeds of the condemnation award or any insurance payable as a result of the destruction or damage, which gross proceeds Seller agrees to assign to Buyer and deliver to Buyer at Closing. Seller will not be obligated to repair or replace damaged improvements. The provisions of the Uniform Vendor and Purchaser Risk Act of the State of Illinois will be applicable to this Agreement, except as modified by this Section 15.

16. **CONDITIONS PRECEDENT TO CLOSING, DEFAULT, AND REMEDIES.**

A. It is a condition precedent to Closing that:

- i. fee simple title to the Property is shown to be good and marketable, subject only to the Permitted Exceptions, as required hereunder;
- ii. the covenants, representations and warranties of Seller contained in Section 14 hereof and elsewhere in this Agreement are true and accurate on the Closing Date in all material respects, or waived by Buyer in writing on the Closing Date; and
- iii. Seller has performed under the Agreement and otherwise has performed all of its covenants and obligations and fulfilled all of the conditions required of it under the Agreement in order to close on the Closing Date.

If any of the foregoing conditions precedent is not satisfied or waived in writing by Buyer, Buyer may, but will not be obligated to, elect, at its option, by notice to Seller, either to: (x) terminate this Agreement, in which event the parties hereto will have no further rights or obligations hereunder, except for those which expressly survive such termination; or (y) close without regard to the failure of such condition. The foregoing election is not intended to be in derogation of, but will be in addition to, Buyer's remedies for Seller's default hereunder, and does not negate, modify or amend the representations, warranties of Seller contained herein, which representations, warranties will survive the Closing as herein provided.

**B. Buyer's Remedies.** IF SELLER FAILS TO CONSUMMATE THE SALE OF THE PROPERTY PURSUANT TO THIS AGREEMENT OR OTHERWISE MATERIALLY DEFAULTS ON ITS OBLIGATIONS HEREUNDER AT OR PRIOR TO CLOSING FOR ANY REASON EXCEPT FAILURE BY BUYER TO PERFORM HEREUNDER, AND SELLER DOES NOT CURE COMMENCE THE PROCESS TO CURE THE BREACH WITHIN FIVE (5) BUSINESS DAYS (WITH RESPECT TO BREACHES OTHER THAN A FAILURE TO CLOSE), OR THREE (3) BUSINESS DAYS (WITH RESPECT TO A SELLER FAILURE TO CLOSE), AS APPLICABLE, AFTER RECEIPT OF WRITTEN NOTICE OF THE BREACH FROM BUYER, THEN SELLER WILL BE IN DEFAULT UNDER THIS AGREEMENT AND BUYER MAY, AT ITS OPTION AND AS ITS SOLE AND EXCLUSIVE REMEDY, EITHER (i) TERMINATE THIS AGREEMENT AND RECEIVE THE RETURN OF THE EARNEST MONEY AND ANY EXTENSION PAYMENTS, AND SELLER SHALL PAY TO BUYER AN AMOUNT EQUAL TO BUYER'S OUT OF POCKET COSTS INCURRED RELATED TO ITS DUE DILIGENCE, INVESTIGATION AND ENTITLEMENT OF THE PROPERTY, INCLUDING, WITHOUT LIMITATION, ENGINEERING, ENVIRONMENTAL, PHYSICAL INSPECTION, PLANNING, SURVEYING, ARCHITECTURAL, MUNICIPAL REVIEW AND ATTORNEYS' FEES, WHICH SHALL BE DOCUMENTED TO SELLER'S REASONABLE SATISFACTION AND SHALL NOT EXCEED TWENTY-FIVE THOUSAND DOLLARS (\$25,000.00), (ii) ENFORCE SPECIFIC PERFORMANCE OF THIS AGREEMENT; PROVIDED, HOWEVER, IF SPECIFIC PERFORMANCE IS NOT AVAILABLE FOR ANY REASON, BUYER MAY PURSUE ITS DAMAGES AND/OR ANY OTHER REMEDY AT LAW OR IN EQUITY, OR (iii) WAIVE SAID FAILURE OR BREACH AND PROCEED TO CLOSING WITHOUT ANY REDUCTION IN THE PURCHASE PRICE. BUYER'S REMEDIES SHALL BE LIMITED TO THOSE DESCRIBED IN THIS SECTION 16.B. IN NO EVENT SHALL SELLER'S DIRECT OR INDIRECT PARTNERS, SHAREHOLDERS, MEMBERS, MANAGERS, OWNERS OR AFFILIATES, ANY OFFICER OR MANAGER, DIRECTOR, EMPLOYEE OR AGENT OF THE FOREGOING, OR ANY AFFILIATE OR CONTROLLING PERSON THEREOF HAVE ANY LIABILITY FOR ANY CLAIM, CAUSE OF ACTION OR OTHER LIABILITY ARISING OUT OF OR RELATING TO THIS AGREEMENT OR THE PROPERTY, WHETHER BASED ON CONTRACT, COMMON LAW, STATUTE, EQUITY OR OTHERWISE.

SELLER AND BUYER ACKNOWLEDGE THAT THEY HAVE READ AND UNDERSTAND THE PROVISIONS OF THIS SECTION AND BY THEIR INITIALS IMMEDIATELY BELOW AGREE TO BE BOUND BY ITS TERMS.

SELLER'S INITIALS

BUYER'S INITIALS

C. **Seller's Remedies.** IF BUYER FAILS TO CONSUMMATE THE PURCHASE OF THE PROPERTY PURSUANT TO THIS AGREEMENT OR OTHERWISE MATERIALLY DEFAULTS ON ITS OBLIGATIONS HEREUNDER AT OR PRIOR TO CLOSING FOR ANY REASON EXCEPT FAILURE BY SELLER TO PERFORM HEREUNDER, AND BUYER FAILS TO CURE OR TO COMMENCE THE PROCESS TO CURE THE BREACH WITHIN FIVE (5) BUSINESS DAYS (WITH RESPECT TO BREACHES OTHER THAN A FAILURE TO CLOSE), OR THREE (3) BUSINESS DAYS (WITH RESPECT TO A BUYER FAILURE TO CLOSE), AS APPLICABLE, AFTER RECEIPT OF WRITTEN NOTICE OF THE BREACH FROM SELLER, THEN BUYER WILL BE IN DEFAULT UNDER THIS AGREEMENT, AND SELLER SHALL BE ENTITLED, AS ITS SOLE AND EXCLUSIVE REMEDY (EXCEPT AS OTHERWISE EXPRESSLY PROVIDED IN THIS AGREEMENT) TO TERMINATE THIS AGREEMENT AND RETAIN THE EARNEST MONEY AND ANY EXTENSION PAYMENTS (TO THE EXTENT ALL OR ANY PORTION THEREOF SHALL HAVE BEEN DEPOSITED), AS LIQUIDATED DAMAGES AND NOT AS A PENALTY, IN FULL SATISFACTION OF CLAIMS AGAINST BUYER HEREUNDER. SELLER AND BUYER AGREE THAT SELLER'S DAMAGES RESULTING FROM BUYER'S DEFAULT ARE DIFFICULT, IF NOT IMPOSSIBLE, TO DETERMINE AND THE DEPOSIT AND ANY EXTENSION PAYMENTS ARE A FAIR ESTIMATE OF THOSE DAMAGES WHICH HAS BEEN AGREED TO IN AN EFFORT TO CAUSE THE AMOUNT OF SUCH DAMAGES TO BE CERTAIN, AND THAT BUYER SEEKS TO LIMIT ITS LIABILITY UNDER THIS AGREEMENT TO THE AMOUNT OF THE DEPOSIT AND ANY EXTENSION PAYMENTS IN THE EVENT THIS AGREEMENT IS TERMINATED AND THE TRANSACTION CONTEMPLATED BY THIS AGREEMENT DOES NOT CLOSE DUE TO A DEFAULT OF BUYER UNDER THIS AGREEMENT. SUCH RETENTION OF THE DEPOSIT AND ANY EXTENSION PAYMENTS BY SELLER IS INTENDED TO CONSTITUTE LIQUIDATED DAMAGES TO SELLER AND SHALL NOT BE DEEMED TO CONSTITUTE A FORFEITURE OR PENALTY IN VIOLATION OF APPLICABLE LAW. IF THE CLOSING OCCURS IN ACCORDANCE WITH THE TERMS OF THIS AGREEMENT, THE DEPOSIT AND ANY EXTENSION PAYMENTS SHALL BE APPLIED AS A CREDIT TOWARD THE PURCHASE PRICE. NOTWITHSTANDING ANYTHING IN THIS SECTION 16.C. TO THE CONTRARY, IN THE EVENT OF BUYER'S DEFAULT OR A TERMINATION OF THIS AGREEMENT, SELLER SHALL HAVE ALL REMEDIES AVAILABLE AT LAW OR IN EQUITY IN THE EVENT BUYER OR ANY PARTY RELATED TO OR AFFILIATED WITH BUYER IS ASSERTING ANY CLAIMS OR RIGHT TO THE PROPERTY THAT WOULD OTHERWISE DELAY OR PREVENT SELLER FROM HAVING CLEAR, INDEFEASIBLE AND MARKETABLE TITLE TO THE PROPERTY. IN ALL OTHER EVENTS SELLER'S REMEDIES SHALL BE LIMITED TO THOSE DESCRIBED IN THIS SECTION 16.C. IF CLOSING IS CONSUMMATED, SELLER SHALL HAVE ALL REMEDIES AVAILABLE AT LAW OR IN EQUITY IN THE EVENT BUYER FAILS TO PERFORM ANY OBLIGATION OF BUYER UNDER THIS AGREEMENT; PROVIDED, IN NO EVENT SHALL BUYER BE LIABLE TO SELLER FOR INCIDENTAL, CONSEQUENTIAL, OR PUNITIVE DAMAGES.

SELLER AND BUYER ACKNOWLEDGE THAT THEY HAVE READ AND UNDERSTAND THE PROVISIONS OF THIS SECTION AND BY THEIR INITIALS IMMEDIATELY BELOW AGREE TO BE BOUND BY ITS TERMS.

SELLER'S INITIALS

BUYER'S INITIALS

D. Notwithstanding the foregoing, the parties agree that no default of or by either party will be deemed to have occurred unless and until notice of any failure by the non-defaulting party has been sent to the defaulting party and the defaulting party has been given a period of five (5) business days from receipt of the notice to cure the default.

17. **BINDING EFFECT.** This Agreement, and the terms, covenants, and conditions herein contained, shall inure to the benefit of and be binding upon the heirs, personal representatives, successors, and assigns of each of the parties hereto. Buyer may not assign or otherwise transfer its rights or obligations under this Agreement, provided that the original Buyer named herein (the "**Original Buyer**") may assign its rights under this Agreement upon the following conditions: (a) the assignment shall only be effective from and after the Closing Date; (b) the assignee of the Original Buyer must be an entity directly or indirectly controlled by the Original Buyer (with "control" meaning the ability to make all decisions (including the power to veto) in respect of the ownership, management and operation of the applicable entity and without veto by third parties); (c) the Original Buyer shall remain primarily liable for the performance of Buyer's obligations; (d) the assignee shall assume all obligations of the Original Buyer effective from and after the Closing Date; and (e) a copy of the fully executed written assignment and assumption agreement shall be delivered to Seller as of the Closing Date.

18. **BROKERAGE.** Each Party shall individually pay for all costs and fees associated with any broker they have or may retain as part of the purchase and sale of the Property (i.e. Seller pays for Seller's broker; Buyer pays for Buyer's broker). Buyer does not have a broker and will not owe a commission pursuant to this Section 18. Seller and Buyer hereby agree to indemnify and hold one another harmless for any claim (including reasonable expenses incurred in defending such claim) made by a broker or sales agent or similar Party in connection with this transaction and claiming by or through the indemnifying Party and not disclosed herein. The provisions of this Section shall survive the Closing.

19. **BULK SALES.** At least twenty (20) days prior to the Closing, Seller must, and Buyer may, notify the Illinois Department of Revenue ("**Department**") of the intended sale of the Property and request the Department to make a determination as to whether Seller has an assessed, but unpaid, amount of tax, penalties, or interest under 35 ILCS 5/902(d) or 35 ILCS 120/5j (collectively the "**Bulk Sale Act**"). If Buyer requests a Department clearance, Seller must deliver to Buyer, at or prior to Closing, evidence that the sale of the Property to Buyer hereunder is not subject to, and does not subject Buyer to liability under the Bulk Sale Act ("**Release**"). At the request of Buyer, prior to the Closing, Seller must, and Buyer may, notify the Illinois Department of Employment Security (the "**IDES**") of the intended sale of the Property and request the IDES to make a determination as to whether Seller has an assessed, but unpaid, amount of tax, penalties, or interest under the Section 2600 of the Illinois Unemployment Insurance Act (collectively part of the "**Bulk Sale Act**"). If Buyer requests an IDES determination, Seller must deliver to Buyer, at or prior to Closing evidence that the sale of the Property to Buyer hereunder is not subject to, and does not subject Buyer to liability under the Bulk Sale Act (collectively, "**Release**"). Buyer may, at the Closing, deduct and withhold from the proceeds that are due Seller the amount necessary to comply with the withholding requirements imposed by the Bulk Sale Act, provided that such amounts are deposited in escrow at Closing and released to Seller upon obtaining a release from the Department or otherwise satisfying any amounts due under the Bulk Sale Act. Seller must indemnify, defend with counsel of Buyer's choosing, and hold harmless Buyer, and its commissioners, officers, employees, agents, successors and assigns, harmless from any and all obligations, liabilities, claims, demands, losses, expenses, or damages arising from Seller's failure to (i) provide any required notice of its sale of the Property to the appropriate state, county, or municipal governmental authorities, (ii) pay any and all taxes and other amounts due in

connection with its ownership, operation or sale of the Property, or (iii) otherwise comply with any bulk sales laws of the State of Illinois. The foregoing indemnity will survive the Closing Date.

20. **NOTICES**. Except as otherwise specified herein, any notice required to be given under this Agreement must be in writing and must be delivered (i) personally, (ii) by a reputable overnight courier, (iii) by certified mail, return receipt requested, and deposited in the U.S. Mail, postage prepaid, or (iv) by email. Unless otherwise expressly provided in this Agreement, notices will be deemed received upon the earlier of: (a) actual receipt; (b) one business day after deposit with an overnight courier as evidenced by a receipt of deposit; (c) three business days following deposit in the U.S. mail, as evidenced by a return receipt; or (d) by email. Email notices will be deemed received by the addressee upon explicit or implicit acknowledgment of receipt by the addressee. By notice complying with the requirements of this Section, each party will have the right to change its address or its addressee, or both, for all future notices to the other party, but no notice of a change of addressee or address will be effective until actually received.

Notices to Buyer will be addressed to, and delivered at, the following address:

City of Des Plaines  
1420 Miner Street  
Des Plaines, IL 60016  
Attention: Dorothy Wisniewski, City Manager  
Email: [dwisniewski@desplainesil.gov](mailto:dwisniewski@desplainesil.gov)

With a copy to: Elrod Friedman LLP  
350 North Clark Street  
Second Floor  
Chicago, Illinois 60654  
Attn: Peter Friedman and Andrew Carlins  
Email: [peter.friedman@elrodfriedman.com](mailto:peter.friedman@elrodfriedman.com)  
[andrew.carlins@elrodfriedman.com](mailto:andrew.carlins@elrodfriedman.com)

Notices to Seller will be addressed to, and delivered at, the following address:

YMCA of Metropolitan Chicago  
1030 W. Van Buren Street  
Chicago, IL 60607  
Attn: Basil Fitzsimons, VP of Real Estate & Facilities  
Email: [bfitzsimon@ymcachicago](mailto:bfitzsimon@ymcachicago)

With a copy to:  
YMCA of Metropolitan Chicago  
1030 W. Van Buren Street  
Chicago, IL 60607  
Attn: Justin Shlensky, VP of Legal & Risk Management  
Email: [jshlensky@ymcachicago.org](mailto:jshlensky@ymcachicago.org), and [legal@ymcachicago.org](mailto:legal@ymcachicago.org)

21. **RIGHT OF WAIVER**. Both Buyer and Seller may waive a condition of the Closing, which is an obligation of the other party, without waiver of any other condition or other prejudice of its rights hereunder. Such waiver by a party will, unless otherwise herein provided, be in a writing signed by the waiving party and delivered to the other party.

22. **DISCLOSURE OF INTERESTS**. In accordance with Illinois law, 50 ILCS 105/3.1, prior to execution of this Agreement, an owner, authorized trustee, corporate official or managing agent of Seller must submit a sworn affidavit to Buyer disclosing the identity of every owner and beneficiary having any interest, real or personal, in the Property, and every shareholder entitled to receive more than 7½% of the total distributable income of any corporation having any real interest, real or personal, in the Property, or, alternatively, if a corporation's stock is publicly traded, a sworn affidavit by an officer of the corporation or its managing agent that there is no readily known individual having a greater than 7½% percent interest, real or personal, in the Property. The sworn affidavit will be substantially similar to the one in **EXHIBIT C** attached hereto and made a part hereof.

23. **ASSIGNMENT**. Buyer may assign any of Buyer's rights hereunder or any part thereof to any person, firm, partnership, corporation or other entity without the prior written approval of Seller. Provided, however, that any assignee shall assume all of the duties, obligations and liabilities of assignor under this Agreement and Buyer shall remain fully obligated under this Agreement.

24. **MISCELLANEOUS**.

A. **Time of the Essence**. Time is of the essence in the performance of this Agreement.

B. **Calendar Days; Calculation of Time Periods**. Unless otherwise specified in this Agreement, references to days in this Agreement are to calendar days. Unless otherwise specified in this Agreement, in computing any period of time under this Agreement, the day of the act or event on which the designated period of time begins to run is not to be included and the last day of the period so computed is to be included, unless the last day is a Saturday, Sunday or legal holiday under the laws of the State in which the Property is located, in which event the period will run until the end of the next day which is not a Saturday, Sunday or legal holiday. The final day of any period will be deemed to end at 5:00 p.m., Central prevailing time.

C. **Rights Cumulative**. Unless otherwise provided in this Agreement, all rights, remedies, and benefits provided by this Agreement are cumulative and are not exclusive of any other rights, remedies, and benefits allowed by law.

D. **Non-Waiver**. No waiver of any provision of this Agreement, and no delay in exercising or failure to exercise any right or authority set forth in this Agreement, will be deemed to or constitute a waiver of any other provision of this Agreement (whether or not similar) nor will any waiver be deemed to or constitute a continuing waiver unless otherwise expressly provided in this Agreement.

E. **Consents**. Unless otherwise provided in this Agreement, all required permissions, authorizations, approvals, acknowledgments, or similar indications of assent of any party must be in writing.

F. **Governing Laws**. This Agreement will be interpreted according to the internal laws, but not the conflict of laws rules, of the State of Illinois.

G. **Venue**. Exclusive jurisdiction with regard to the any actions or proceedings arising from, relating to, or in connection with this Agreement will be in the Illinois circuit court for Cook County, Illinois, or, where applicable, in the federal court for the Northern District of Illinois.

H. **Severability**. If any provision of this Agreement is held by a court of competent jurisdiction to be invalid, void, or unenforceable, the Buyer will have the right, in its sole and absolute discretion, to determine if (i) the remainder of the provisions of this Agreement will remain in full force and effect and will in no way be affected, impaired, or invalidated; or (ii) the entire Agreement is invalid, void, and unenforceable.

I. **Survival**. The provisions of this Agreement that contemplate performance after the Closing and the obligations of the parties not fully performed at the Closing (other than any unfulfilled closing conditions which have been waived or deemed waived by the other Party) shall survive the Closing for the time period contemplated herein and shall not be deemed to be merged into or waived by the instruments of Closing.

J. **Entire Agreement**. This Agreement constitutes the entire agreement between the parties, and supersedes any and all previous or contemporaneous oral or written agreements and negotiations between the parties, with respect to the Property.

K. **Interpretation**. This Agreement will be construed without regard to the identity of the party who drafted the various provisions of this Agreement. Every provision of this Agreement will be construed as though all parties to this Agreement participated equally in the drafting of this Agreement. Any rule or construction that a document is to be construed against the drafting party will not be applicable to this Agreement.

L. **Exhibits**. Exhibits A through C attached to this Agreement are incorporated in and made a part of this Agreement.

M. **Amendments and Modifications**. No amendment to this Agreement will be effective unless and until the amendment is in writing, properly approved in accordance with applicable procedures, and executed by all parties.

N. **Counterpart Execution**. This Agreement may be executed in counterparts, each of which is deemed to be an original but all of which will constitute one and the same instrument. Facsimile or electronic counterpart copies of this Agreement will be considered for all purposes, including delivery, as originals.

O. **No Recordation**. Except for disclosures required by Buyer as a municipal entity, there shall be no recordation of either this Agreement or any memorandum hereof, or any affidavit pertaining hereto, and any such recordation of this Agreement or memorandum or affidavit by Buyer without the prior written consent of Seller shall constitute a default hereunder by Buyer, whereupon Seller shall be entitled to any and all remedies as allowed under this Agreement.

P. **Further Assurances**. In addition to the acts and deeds recited herein and contemplated to be performed, executed and/or delivered by either party at Closing, each party agrees to perform, execute and deliver, but without any obligation to incur any additional liability or expense, on or after the Closing any further deliveries and assurances as may be reasonably necessary to consummate the transactions contemplated hereby or to further perfect the conveyance, transfer and assignment of the Property to Buyer.

Q. **Discharge of Obligations**. The recordation of the Deed at Closing shall be deemed to be a full performance and discharge of every representation and warranty made by Seller or Buyer herein and every agreement and obligation on the part of Seller or Buyer to be

performed pursuant to the provisions of this Agreement, except those which are herein specifically stated to survive Closing.

R. **Limitation on Liability.** Buyer acknowledges and agrees that its recourse against Seller under this Agreement for a default by Seller hereunder or any agreement related hereto is limited to the remedies set forth in Section 16 hereof. In no event shall Buyer seek or attempt to obtain any recovery or judgment against any of Seller's other assets (if any) other than the Property or against any Seller Parties. In no event shall Buyer be entitled to seek or obtain any other damages of any kind, including speculative, direct, or punitive damages, and Buyer hereby waives any right to any of these. In no event shall Seller be entitled to seek or obtain speculative, direct, or punitive damages, and Seller hereby waives any right to any of these. This Section shall survive the Closing or any termination of this Agreement.

S. **No Third Party Beneficiary.** The provisions of this Agreement and of the documents to be executed and delivered at Closing are and will be for the benefit of Seller and Buyer only and are not for the benefit of any third party, and accordingly, no third party shall have the right to enforce the provisions of this Agreement or of the documents to be executed and delivered at Closing. Except as otherwise stated in agreement.

T. **Real Estate Procedures Act of 1974.** The parties hereby agree to make all disclosures and do all things necessary to comply with the applicable provisions of the Real Estate Procedures Act of 1974. In the event that either party will fail to make appropriate disclosures when asked, such failure will be considered a breach on the part of said party.

U. **Authority to Sign.** The parties warrant and represent that the execution, delivery of and performance under this Agreement is pursuant to authority, validly and duly conferred upon the parties and the signatories hereto.

V. **Grammatical Usage and Construction.** In construing this Agreement, plural terms are to be substituted for singular and singular for plural, in any place in which the context requires.

W. **Headings.** The headings, titles, and captions in this Agreement are used only for convenience and in no way define, limit, extend, or describe the scope or intent of this Agreement or any of the substantive provisions of this Agreement.

X. **Prevailing Party.** In the event of a judicial proceeding brought by one party against the other party on account of the negotiation, execution, performance, or breach of, or default under, this Agreement, the prevailing party in the judicial proceeding will be entitled to reimbursement from the unsuccessful party of all reasonable costs and expenses, including reasonable attorneys' fees, incurred in connection with the judicial proceeding.

Y. **1031 Exchange.** Each party will have the right to consummate the transaction as a tax-deferred exchange under Section 1031 of the Internal Revenue Code. Each party will make all reasonable efforts to cooperate with the other party to facilitate the exchange; provided, however, that the Closing Date hereunder will not be delayed as a result of the exchange.

25. **EFFECTIVE DATE.** This Agreement will be deemed dated and become effective on the date that is the later to occur of (a) the date that the authorized signatory of Seller signs this Agreement, and (b) the date that the authorized signatory of Buyer signs this Agreement.

[THIS SPACE INTENTIONALLY LEFT BLANK]

**IN WITNESS WHEREOF**, the parties hereto have executed this Agreement as of the date below their respective signatures.

**SELLER:**

**BUYER:**

**BOARD OF TRUSTEES OF THE YOUNG  
MEN'S CHRISTIAN ASSOCIATION OF  
CHICAGO**

**CITY OF DES PLAINES**, an Illinois  
home rule corporation

By: \_\_\_\_\_

By: \_\_\_\_\_

Name: \_\_\_\_\_

Name: \_\_\_\_\_

Title: \_\_\_\_\_

Title: \_\_\_\_\_

Date: \_\_\_\_\_

Date: \_\_\_\_\_

**APPROVED AS TO FORM ONLY:**

By: \_\_\_\_\_

Name: \_\_\_\_\_

Title: \_\_\_\_\_

Date: \_\_\_\_\_

**EXHIBIT A**

**LEGAL DESCRIPTION OF THE PROPERTY**

**PARCEL 1:**

THAT PORTION OF LOT 'C' OF CUMBERLAND VILLAGE, UNIT NUMBER 1, BEING A SUBDIVISION OF PART OF THE SOUTH WEST FRACTIONAL 1/4 OF FRACTIONAL SECTION 7, TOWNSHIP 41 NORTH, RANGE 12 EAST OF THE THIRD PRINCIPAL MERIDIAN, DESCRIBED AS FOLLOWS: COMMENCING AT THE INTERSECTION OF THE NORTHERLY LINE OF UNITED STATES ROUTE 14 (COMMONLY KNOWN AS THE NORTHWEST HIGHWAY) WITH A LINE, 510.22 FEET WEST OF AND PARALLEL WITH THE EAST LINE OF SAID SOUTH WEST FRACTIONAL 1/4 OF SECTION 7, TOWNSHIP 41 NORTH, RANGE 12 EAST OF THE THIRD PRINCIPAL MERIDIAN, AS MEASURED AT RIGHT ANGLES TO SAID EAST LINE; THENCE NORTH ALONG SAID PARALLEL LINE (AT AN ANGLE OF 59 DEGREES 23 MINUTES 10 SECONDS WITH THE NORTH LINE OF SAID ROUTE 14) 400.84 FEET; THENCE WEST AT AN ANGLE OF 90 DEGREES WITH THE LAST DESCRIBED COURSE, A DISTANCE OF 166.85 FEET, MORE OR LESS, TO A POINT, 260 FEET NORTHEASTERLY OF THE NORTHERLY LINE OF SAID UNITED STATES ROUTE 14 AS MEASURED AT RIGHT ANGLES TO SAID NORTHERLY LINE; THENCE NORTHWESTERLY PARALLEL TO SAID NORTHERLY LINE AND 260 FEET NORTHEASTERLY THEREOF (AS MEASURED AT RIGHT ANGLES THERETO), A DISTANCE OF 253.95 FEET; THENCE SOUTHWESTERLY AT RIGHT ANGLES TO THE LAST DESCRIBED COURSE, 260 FEET TO A POINT ON THE NORTHERLY LINE OF SAID UNITED STATES ROUTE 14, 601.67 FEET NORTHWESTERLY FROM THE POINT OF BEGINNING; THENCE SOUTHEASTERLY 601.67 FEET ALONG SAID NORTHERLY LINE TO THE POINT OF BEGINNING, IN COOK COUNTY, ILLINOIS.

NOTE: PARCEL 1 OF THE LAND IS ALSO KNOWN AS TRACT 'D' OF CUMBERLAND VILLAGE UNIT NUMBER 2 REGISTERED JUNE 1, 1956 N BOOK 48 OF TORRENS PLATS PAGE 30 AS DOCUMENT NUMBER 1673761.

ALSO;

**PARCEL 2:**

LOT 26 AND LOT 27 AND ALL OF VACATED KENTON ROAD LYING WESTERLY OF CAMBRIDGE AVENUE BETWEEN LOTS 26 AND 27 IN H.M. CORNELL & CO'S CUMBERLAND WEST, BEING A SUBDIVISION OF PART OF THE EAST HALF OF THE SOUTHWEST FRACTIONAL QUARTER OF FRACTIONAL SECTION 7, TOWNSHIP 41 NORTH, RANGE 12 EAST OF THE THIRD PRINCIPAL MERIDIAN, IN COOK COUNTY, ILLINOIS, ACCORDING TO THE PLAT THEREOF REGISTERED IN THE OFFICE OF THE REGISTRAR OF TITLES OF COOK COUNTY, ILLINOIS ON MARCH 4, 1955 AS DOCUMENT 1579383.

Property Address: 300 East Northwest Highway, Des Plaines, Illinois

PIN: 09-07-310-005; 09-07-310-020; and 09-07-311-001

**EXHIBIT B**

**PERMITTED EXCEPTIONS**

1. 2025 real estate taxes and subsequent years, not due and payable for the Property.

**EXHIBIT C**  
**DISCLOSURE AFFIDAVIT**  
(attached)

State of Illinois )  
 ) ss.  
County of \_\_\_\_\_ )

### DISCLOSURE AFFIDAVIT

I, \_\_\_\_\_, (“Affiant”) am involved with the owner of \_\_\_\_\_, \_\_\_\_\_, in \_\_\_\_\_ County, State of Illinois, being first duly sworn and having personal knowledge of the matters contained in this Affidavit, swear to the following:

1. That I am over the age of eighteen and the  owner or  authorized trustee or  corporate official or  managing agent or  \_\_\_\_\_ of the grantor (“Grantor”) of the Real Estate (as defined below).

2. That the Real Estate (as defined herein) being conveyed to the “Grantee,” as defined below, is described as:

P.I.N.: 09-07-310-005-0000; 09-07-310-020-0000; and 09-07-311-001-0000  
Commonly known as: 300 East Northwest Highway, Des Plaines, Illinois (“Real Estate”).

3. That I understand that, pursuant to 50 ILCS 105/3.1, Illinois State Law requires the owner, authorized trustee, corporate official or managing agent of Grantor to submit a sworn affidavit to the City of Des Plaines, an Illinois home rule corporation (“Grantee”), disclosing the identity of every owner and beneficiary having any interest, real or personal, in the Real Estate, and every shareholder entitled to receive more than 7½% of the total distributable income of any corporation having any interest, real or personal, in Grantor.

4. As the  owner or  authorized trustee or  corporate official or  managing agent or  \_\_\_\_\_ of the Grantor, I declare under oath that (choose one):

The owners or beneficiaries of the trust are:  
or

The shareholders with more than 7 1/2% interest are:  
or

The corporation is publicly traded and there is no readily known individual having greater than a 7½% interest in the corporation.

This Disclosure Affidavit is made to induce the Grantee to acquire title to the Real Estate in accordance with 50 ILCS 105/3.1.

\_\_\_\_\_  
AFFIANT

SUBSCRIBED AND SWORN to before me  
this \_\_\_\_\_ day of \_\_\_\_\_, 2026.

\_\_\_\_\_  
NOTARY PUBLIC



## CITY MANAGER'S OFFICE

1420 Miner Street  
Des Plaines, IL 60016  
P: 847.391.5488  
desplainesil.gov

## MEMORANDUM

Date: April 23, 2026

To: Mayor Goczkowski and Aldermen of the City Council

From: Dorothy Wisniewski, City Manager *DW*  
Jeff Rogers, AICP, Director of Community and Economic Development *JWR*  
Tim Watkins, Director of Public Works and Engineering

Cc: Peter Friedman, Elrod Friedman, City Attorney for City of Des Plaines

Subject: Consideration of a Resolution approving a Term Sheet for an Economic Incentive and Development Agreement for the former Lattof YMCA building at 300 E. Northwest Highway

**Issue:** For the City Council to consider the Resolution approving a term sheet for the economic incentive and development agreement between the City of Des Plaines and SG Des Plaines, LLC and Spectate Group LLC (the "Developer") for the redevelopment of the property located at 300 E. Northwest Highway, also known as the Lattof YMCA.

**Analysis:** The Northwest Suburban YMCA opened in January 1961 at 300 E. Northwest Highway in Des Plaines as a regional recreation center for the rapidly growing northwest suburbs of Chicago. Designed as a shared community facility, it quickly became a hub for youth and adult programs and indoor sports.

Renamed the Lattof YMCA in 1980 to honor local philanthropist Nicholas M. Lattof, the facility grew into one of the area's largest YMCAs. At its peak, it had the largest membership of any non-residential YMCA in the Chicago region and was reportedly the largest in the world. After decades as a gathering place for suburban families, financial pressures tied to aging infrastructure and the COVID-19 pandemic led to its permanent closure in June 2020.

This parcel is a key lot along Northwest Highway at the west end of the commercial district surrounding the Cumberland Metra train station. The current zoning for this property is C-3 (General Commercial District). The property is improved with a series of interconnected buildings together comprising 98,470 square feet of floor area and is situated on 4.27 acres of land. The property has been and continues to be exempt from all property taxes.

Since the site has been vacant for the last six years, the City has not received any development proposals. During this time, the property has become an attractive nuisance and experienced a decline in property maintenance.

In late December 2025, the City received a proposal from the Nicholas Family of Companies, outlining a

public/private partnership with the City to improve and reactivate the Lattof YMCA with a revitalized concept that would reactivate the property as a tax-paying commercial use. The proposal and preliminary project scope include renovation of approximately 90,000 square feet of the original YMCA facility to support a modern sports complex facility for community recreational uses, along with a bar/restaurant/market.

In light of this reinvestment opportunity and the high-profile nature of the ongoing vacancy, the City Council directed the City Manager to negotiate with the YMCA to purchase the property. Based upon a third-party appraisal shared with the City, conducted by Marous & Company, the appraised value of the properties is \$2.2M. With City Council authority, the City Manager negotiated a purchase price of \$1,850,000.

Concurrently, staff has negotiated parameters of a proposed term sheet with the Developer. The proposed terms are summarized in the following table:

| Section | Deal Point Components  | Summary  |
|---------|------------------------|--|
| 1       | Non-Binding Term Sheet | Final terms will be finalized in a development agreement to be considered separately at a later date.  |
| 2       | Acquisition            | City of Des Plaines would acquire the property and hold it during construction prior to transferring the property to the developer prior to occupancy.   |
| 3       | Ownership              | SG Des Plaines, LLC and Spectate Group, LLC would own the building   |
| 4       | Financing              | <p>City of Des Plaines (City) provides 90% LTC financing (20-Year Term) to SG (at an interest rate of 2.5%) to acquire and renovate the facility estimated at \$19.8M</p> <p>Papanicholas Family provides 10% LTC equity investment to acquire &amp; renovate the facility, estimated at \$2.2M</p> <p>SG pays monthly loan repayment to the City (20-Year Amortization), with the City paid in full at the end of the 20-year term.</p> <p>Estimated interest earnings at the end of 20 years are \$5.3M.</p> |
| 5       | Taxes                  | The operator is responsible for all taxes; however, the City will pursue approval of a Cook County Class 7b property tax incentive intended for properties in need of commercial development with development costs in excess of \$2 million.  |
| 6       | Uses Restricted        | After conveyance of the Property to Owner and until the later of the Loan being repaid and the Class 7b not being in effect, the Property may only be used for the Development.  |
| 7       | Insurance              | The Operator will be required to furnish proof of insurance at amounts commensurate with the value of risk associated with the business as outlined in the term sheet.   |
| 8       | Additional Information | The restaurant concept will generate sales tax and food and beverage tax.  |

**Recommendation:** Based on the consensus reached by the Members of the City Council and previous discussions regarding reactivating key properties within the community to generate revenue, replacing a recreational center will serve as a catalyst project that will further drive economic development and new investment in the vicinity, staff recommends approval of Resolution R-116-26, which approves the terms in the attached term sheet for an economic incentive and development agreement.

**Attachments:**

Resolution R-116-26

Exhibit A – Term Sheet for Economic Incentive and Development Agreement

Exhibit B – Preliminary Project Renderings

Exhibit C – Project Budget

CITY OF DES PLAINES

RESOLUTION R - 116 - 26

**A RESOLUTION APPROVING A TERM SHEET FOR AN ECONOMIC INCENTIVE AND DEVELOPMENT AGREEMENT REGARDING THE PROPERTY AT 300 EAST NORTHWEST HIGHWAY.**

**WHEREAS**, Article VII, Section 10 of the 1970 Illinois Constitution authorizes the City to contract with individuals, associations, and corporations in any manner not prohibited by law or ordinance; and

**WHEREAS**, the City is pursuing acquisition of the property commonly known as 300 East Northwest Highway ("**Property**"); and

**WHEREAS**, the City desires to acquire the Property, have it developed with recreation-related uses, and then convey the Property so that an operator may offer recreation-related uses; and

**WHEREAS**, should the City acquire the Property, in order to facilitate its development, the City has developed a non-binding term sheet setting forth the terms and conditions upon which the City is willing to allow the development of the Property and convey it ("**Term Sheet**"); and

**WHEREAS**, the Term Sheet will be the basis for an economic incentive and development agreement, which agreement, if acceptable to the City Council, will be considered at an open meeting of the City Council for approval; and

**WHEREAS**, the City Council has determined that it is in the best interest of the City to approve the Term Sheet;

**NOW, THEREFORE, BE IT RESOLVED** by the City Council of the City of Des Plaines, Cook County, Illinois, in the exercise of its home rule powers, as follows:

**SECTION 1: RECITALS.** The foregoing recitals are incorporated into, and made a part of, this Resolution as findings of the City Council.

**SECTION 2: APPROVAL OF TERM SHEET.** The City Council hereby approves the Term Sheet, in substantially the form attached to this Resolution as **Exhibit A**, and in a final form to be approved by the General Counsel.

**SECTION 3: AUTHORIZATION TO EXECUTE TERM SHEET.** The City Council hereby authorizes and directs the City Manager and the City Clerk to execute and seal, on behalf of the City, the final Term Sheet.

**SECTION 4: EFFECTIVE DATE.** This Resolution shall be in full force and effect from and after its passage and approval according to law.

**PASSED** this \_\_\_\_ day of \_\_\_\_\_, 2026.

**APPROVED** this \_\_\_\_ day of \_\_\_\_\_, 2026.

**VOTE:** AYES \_\_\_\_ NAYS \_\_\_\_ ABSENT \_\_\_\_

\_\_\_\_\_  
**MAYOR**

ATTEST:

Approved as to form:

\_\_\_\_\_  
**CITY CLERK**

\_\_\_\_\_  
**Peter M. Friedman, General Counsel**

## TERM SHEET FOR ECONOMIC INCENTIVE AND DEVELOPMENT AGREEMENT

by and between

### THE CITY OF DES PLAINES, SG DES PLAINES, LLC, AND SPECTATE GROUP, LLC

The **CITY OF DES PLAINES** (“**City**”) intends to negotiate for and enter into an Economic Incentive and Development Agreement (“**Agreement**”) with **SG DES PLAINES, LLC** (“**Owner**”) and **SPECTATE GROUP, LLC** (“**Operator**,” which along with the Owner are collectively the “**Developer**”) for the property located at 300 East Northwest Highway, Des Plaines, Illinois, P.I.N.s. 09-07-310-005-0000, 09-07-310-020-0000, and 09-07-311-001-0000 (“**Property**”).

1. **Non-Binding Term Sheet.** The City and Developer intend to negotiate the Agreement in good faith and substantially incorporate the terms, obligations, and conditions of this Term Sheet in the Agreement. This Term Sheet is non-binding and only reflects the proposed terms of the Agreement. If the terms are acceptable to the Mayor and City Council, they will be incorporated into the binding Agreement for formal approval at an open meeting of the City Council and executed by both the City and Developer. The Agreement will incorporate additional terms and conditions including, without limitation, guaranties, indemnification, and remedies.
2. **Agreement Overview.** The Agreement will provide that:
  - a. The City will endeavor to acquire the Property on terms acceptable to the City, with input from Owner on title-related matters;
  - b. If the City acquires the Property, Developer will be entitled to make improvements to the Property as approved by the City to renovate and modernize the existing facility to support the recreation-related uses in the attached **Exhibit A** as generally depicted in the preliminary concept plans in the attached **Exhibit B** (“**Development**”);
  - c. Upon completion of the Development in accordance with the Agreement, the City will convey the Property to Owner; and
  - d. Operator will operate the Development.

The Agreement will obligate Developer to obtain all permits and approvals necessary to improve the Property and operate the Development including, without limitation, zoning approvals (if applicable), building permits, a business registration, and a liquor license. The Agreement will include deadlines for Developer to apply for and obtain the permits and approvals.

3. **Property Acquisition and Conveyance.** As of the date of this Term Sheet, the Property is owned by a third-party. The City will endeavor to acquire the Property on terms acceptable to the City, with input from Owner on title-related matters. If the City is unable to acquire the Property on terms acceptable to it, the Agreement will terminate and no party to the Agreement will be liable to the other. If the City acquires the Property, upon completion of the Development in accordance with the Agreement, the City will convey the Property to Owner. Simultaneous with the conveyance, Owner will grant the City a right of reverter allowing the City to reenter and retake the Property if the Loan (defined below) is not repaid when due and a right of first offer allowing the City to acquire the

Property if the Development is completed and Owner desires to sell the Property prior to repayment of the Loan.

4. **Construction of the Development.**

- a. **Permit Fees:** Developer will pay City-imposed permit fees for the Development.
- b. **Prevailing Wage:** Developer must comply, and will cause all contractors constructing the Development to comply, with the Illinois Prevailing Wage Act and ensure that all laborers, workers, and mechanics working on the Development are paid no less than the prevailing wage required by the Act.
- c. **Indemnity and Insurance:** During construction, Developer must indemnify, defend, and hold harmless the City and its elected officials, employees, agents, and attorneys from all claims, costs, and expenses related to the Development. Developer must provide insurance in the types and amounts set forth in the Agreement naming the City and its elected officials, employees, agents, and attorneys as additional insureds on a primary and noncontributory basis with a waiver of subrogation of any insurance held by the additional insureds.

5. **Development Timeline.** If the City acquires the Property on or before July 1, 2026, Developer will diligently construct the Development in accordance with the following schedule, subject to changes approved by the City and Developer:

- a. **Permits:** All permits for the Development must be obtained on or before October 2, 2026.
- b. **Construction:** Construction of the Development must commence on or before October 5, 2026.
- c. **Completion and Operating:** A final certificate of occupancy for the Development from the City must be obtained, and the Development must be open to the public and operating, on or before September 6, 2027.

6. **Financing.** If the City acquires the Property, the City will finance a portion of the costs of the Development by providing Developer with a loan on the following terms ("**Loan**"):

- a. **Conditions Precedent:** In order to have a right to draw on the Loan initially and on an ongoing basis, Developer must (i) provide the City with adequate written proof that Developer obtained all financing necessary to construct the Development, other than the Loan ("**Other Funding**"); and (ii) be in compliance with its obligations in the Agreement.
- b. **Principal Amount:** Lesser of 90% of costs of constructing the Development in the attached **Exhibit C** and \$19,800,000.
- c. **Interest:** Begins to accrue upon the final draw at an annual simple interest rate of 2.5% of the principal amount disbursed.

- d. **Term and Repayment:** 20-year term for repayment of principal and interest commences 30 days after a Certificate of Occupancy for the Development is issued by the City, with no prepayment penalty.
- e. **Disbursements:** From a construction escrow administered by an escrow agent acceptable to the City and Developer upon presentment of documents and information set forth in the Agreement including, without limitation, lien waivers, invoices, and proof of payment.
- f. **Security:** At the time of the first draw and until the Loan is repaid, a personal guaranty from Nicholas Papanicholas, Jr. will secure repayment of the Loan, with reasonable financial and income statements to be provided related to the personal guaranty. Upon conveyance of the Property to Owner and until the Loan is repaid, a mortgage on the Property with a first priority lien will secure repayment of the Loan in addition to the personal guaranty.
- g. **Loan Eligible Costs:** The Loan will be used to pay for those development costs identified in the budget and noted herein on Exhibit C.

Developer is responsible for obtaining the Other Funding. The Other Funding must be subordinate to the Loan, and cannot be attached to the Property, until the Loan is repaid.

- 7. **Class 7b Incentive.** The City and Developer will pursue a Class 7b assessment incentive for the Property from Cook County.
- 8. **Uses Restricted.** After conveyance of the Property to Owner and until the later of the Loan being repaid and the Class 7b not being in effect, the Property may only be used for the Development.
- 9. **Term.** The Agreement will commence on the date it is executed by all parties. The Agreement will terminate upon the earlier of the City being unable to acquire the Property and full repayment of the Loan, except that certain terms including, without limitation, indemnification, insurance, and use restrictions will continue in effect for the duration set forth in the Agreement.

**[SIGNATURE PAGE FOLLOWS]**

**OWNER: SG DES PLAINES, LLC**

\_\_\_\_\_  
Signature

\_\_\_\_\_  
Title

\_\_\_\_\_  
Date

**Attest:**

\_\_\_\_\_  
Signature

\_\_\_\_\_  
Title

\_\_\_\_\_  
Date

**OPERATOR: SPECTATE GROUP, LLC**

\_\_\_\_\_  
Signature

\_\_\_\_\_  
Title

\_\_\_\_\_  
Date

**Attest:**

\_\_\_\_\_  
Signature

\_\_\_\_\_  
Title

\_\_\_\_\_  
Date

**CITY OF DES PLAINES**

\_\_\_\_\_  
City Manager

\_\_\_\_\_  
Date

**Attest:**

\_\_\_\_\_  
City Clerk

\_\_\_\_\_  
Date

**EXHIBIT A  
DEVELOPMENT USES**

- Pickleball Courts (South Gym)
- Padel Courts (Fieldhouse)
- Basketball Court (North Gym)
- Exterior Paddlecourts (Platform Tennis – Played in Winter)
- Walking Track around perimeter of field house
- Racquetball/Handball (Existing Courts)
- Mahjong Hall
- Golf Simulator Area
- Golf Putting Area
- Fitness/Weights/Cardio
- Pilates Studio
- Hatty's Club Bar/Restaurant plus Hatty's Market (Main Pool Area)
- Academic Area
- Physical Therapy (1,500 SF max)
- Co-Working Area
- Locker Room Facilities including great showers, cold/hot plunge, steam, sauna, relaxation/recovery lounge (TVs with soft seating, red light sauna room)
- Main Reception Area



**INA**  
NICHOLAS  
SPECTATE  
GROUP

# NICHOLAS & ASSOCIATES, INC.

1001 Feehanville Drive, Mount Prospect, IL 60056 | Phone (847) 394.6200 | Fax (847) 394.6205



PROJECT: DATE:

**Lattof YMCA - Adaptive Re-Use, Renovation, Remediation, Façade Enhancements**  
**Complete Renovation & Exterior Improvements of the existing Lattof YMCA Building & Site**

**3/13/2026**

| ITEM                               | Description                                      | Type of Construction | SqFt   | \$/SqFt  | Budget              | Comments/Overview |
|------------------------------------|--|----------------------|--------|----------|---------------------|-------------------|
| <b>Des Plaines, IL</b>             |  |                      |        |          |                     |                   |
| 1                                  | Interior Demolition                              | Renovation           | 1 Lot  | \$5.00   | \$300,000           |                   |
| 2                                  | Lower Level Renovations                          | Renovation           | 25,258 | \$18.00  | \$454,644           |                   |
| 3                                  | Main Level Renovations                           | Renovation           | 35,472 | \$125.00 | \$4,434,000         |                   |
| 4                                  | Main Level Restaurant Renovations                | Renovation           | 6,800  | \$300.00 | \$2,040,000         |                   |
| 5                                  | 2nd Floor Renovations                            | Renovation           | 46,128 | \$125.00 | \$5,766,000         |                   |
| 6                                  | Exterior Façade/Window Replacements              | Renovation           | 1 Lot  | 1 Lot    | \$950,000           |                   |
| 7                                  | Roof Replacement                                 | Renovation           | 45,000 | \$15.00  | \$675,000           |                   |
| 8                                  | Sitework - Parking Lot Resurface + Paddle Courts | Sitework             | 1      | Allow    | \$1,250,000         |                   |
| <b>Sub-Total Construction Cost</b> |  |                      |        |          | <b>\$15,869,644</b> |                   |

|   |                     |
|---|---------------------|
| Construction Contingency:                       | \$500,000           |
| <b>Subtotal</b>                                 | <b>\$16,369,644</b> |
| Builder's Risk Insurance:                       | \$25,000            |
| GL Insurance:                                   | \$117,861           |
| CM Fee:   | \$654,786           |
| Fixed General Conditions:                       | \$574,300           |
| A/E Professional Fees:                          | \$818,482           |
| Asbestos Abatement/Lead Remediation/Consulting: | \$425,000           |
| Permit Fees:                                    | \$160,000           |
| Closing Costs/Legal/Title/Draws:                | \$75,000            |
| Geotechnical testing & survey work:             | \$30,000            |
| Fixed Furniture & Equipment (FFE)               | \$600,000           |
| Technology:                                     | \$300,000           |

|  |                     |
|--|---------------------|
| <b>Total Preliminary Budget Assessment</b> | <b>\$20,150,073</b> |
| <b>Building &amp; Property Purchase</b>    | <b>\$1,850,000</b>  |
| <b>Total Project Costs w/Property</b>      | <b>\$22,000,073</b> |

| Project Funding Sources                                    | 90/10 Structure | Amount       |
|--|-----------------|--------------|
| City of Des Plaines Project Loan (2.5% Interest Rate)      | 90%             | \$19,800,066 |
| SG Des Plaines, LLC. (Nicholas Family of Companies Equity) | 10%             | \$2,200,007  |

**COMMUNITY AND ECONOMIC  
DEVELOPMENT DEPARTMENT**

1420 Miner Street  
Des Plaines, IL 60016  
P: 847.391.5380  
desplainesil.gov

**MEMORANDUM**

**Date:** April 23, 2026

**To:** Dorothy Wisniewski, City Manager

**From:** Jonathan Stytz, AICP, Senior Planner JS

**Cc:** Jonathan Mendel, AICP, Assistant Director of Community & Economic Development

**Subject:** Consideration of an Ordinance Approving a Conditional Use for an Electronic Message Board Sign and a Major Variation for Sign Area for ALM 7 LLC and DPM LLC at 999 E. Touhy Avenue, Case #26-008-CU-V (5<sup>th</sup> Ward)

**Issue:** The petitioner requests a conditional use and a major variation to allow an EMB sign on the subject property in the C-2 Limited Office Commercial district at 999 E. Touhy Avenue that exceeds the maximum sign area permitted for an EMB sign for a qualified property.

**Petitioners/Owners:** ALM 7 LLC and DPM LLC (Representative: Dante Monteverde, 999 E. Touhy Avenue, Suite 120, Des Plaines, IL 60018)

**Case Number:** #26-008-CU-V

**PIN:** 09-32-101-030-0000

**Ward Number:** #5, Alderman Thomas Merlin

**Existing Zoning:** C-2, Limited Office Commercial district

**Existing Land Use:** Multi-Tenant Office Building with Off-Street Parking Area

**Surrounding Zoning:**  
 North: R-1, Single Family Residential District (City of Des Plaines)  
 South: PD-0, Planned Development District (City of Chicago)  
 East: C-2, Limited Office Commercial district (City of Des Plaines)  
 West: C-3, General Commercial District (City of Des Plaines)

**Surrounding Land Uses:**  
 North: Single Family Residences (residential) / Park (recreational)  
 South: Industrial Warehouses (industrial)  
 East: Multi-Tenant Office Building (commercial)  
 West: Convenience Mart Fueling Station (commercial)

- Street Classification:** Touhy Avenue is classified as an *other principal arterial* road under Illinois Department of Transportation (IDOT) jurisdiction.
- Comprehensive Plan:** The Comprehensive Plan designates this site as *Commercial*.
- Property/Zoning History:** The subject property was annexed into the City in 1966 as an office building with an off-street parking lot<sup>1</sup>. Based on City records, a conditional use was approved June 20, 2011 through Ordinance Z-18-11 (attached) to allow a 45-foot-tall, 500-square-foot EMB sign to be installed on the subject property, which is classified as a qualified EMB property pursuant to Section 12-11-5.G.7 of the Zoning Ordinance. There are existing items to address related to parking lot improvements and fire inspections, which both must be addressed to comply with all current regulations.

### CONDITIONAL USE

**Request Summary:**

*Overview*

The petitioner requests replacing an existing Electronic Message Board (EMB) sign, as defined below, on the subject property to advertise for the specific uses within the multi-tenant office building and various City of Des Plaines messages pursuant to the current community messaging agreement.

SIGN, ELECTRONIC MESSAGE BOARD: A sign whose informational content can be changed or altered by manual or electric, electromechanical or electronic means (Section 12-13-3 of the Zoning Ordinance).

Pursuant to Section 12-11-5.G of the Zoning Ordinance, an EMB sign is a separate sign type that is only allowed in certain zoning districts and under specific regulations.

*Qualified EMB Property Exception*

Pursuant to Section 12-11-5.G.7 of the Zoning Ordinance, properties that meet the below criteria are classified as a qualified EMB property and are allowed additional EMB sign allowances than regular EMB signs:

- Occupies a parcel of land of not less than 15 acres zoned C-2 or C-3 or contiguous parcels of land of not less than 15 acres zoned C-2 or C-3 with either vehicular cross access easements or shared parking agreements that are recorded with the Cook County Recorder of Deeds;
- Is improved with multi-story, multi-tenanted office building(s) that have more than 400,000 square feet of rentable space; and
- Has a combined frontage of at least 200 linear feet on I-90 or I-294.

In 2011, Ordinance Z-18-11 approved a conditional use for a 45-foot-tall, 500-square-foot EMB sign on the basis that the subject property met all requirements to be classified as a qualified EMB property. Staff confirms the above Qualified EMB property criteria are still met today.

---

<sup>1</sup> <https://www.historicaerials.com/location/41.625/-87.875/T1890/16>. Retrieved April 7, 2026.

*EMB Sign Regulations for Qualified EMB Properties*

An EMB sign on a qualified EMB property has slightly different standards in Section 12-11-6.B than an EMB sign on a typical, non-qualified EMB property but is still regulated by location, quantity, size, and operation to minimize any adverse effects on surrounding developments.

- **Location:** Qualified EMB properties must be located in either the C-2 or C-3 zoning districts and a conditional use is required to allow the installation of an EMB sign under the qualified EMB property exception in Section 12-11-5.G.7 of the Zoning Ordinance. Any EMB sign associated with a qualified EMB property shall be: (i) located between I-90 or I-294 and the structure(s) on the subject qualified EMB property, and (ii) screened from any residential property.
- **Quantity:** Only one EMB sign is permitted per qualified EMB property even in the case of business parks, retail centers, and multi-lot uses<sup>2</sup>.
- **Size:** An EMB sign on qualified EMB properties cannot exceed 500 square feet in area<sup>3</sup>.
- **Operation:** The changeable copy on the EMB sign must be specific to the businesses or organizations residing on the qualified EMB property and is only for tenants with a lease of 3 years, actually occupies and operates a space of at least 500 square feet within the building. The EMB sign cannot make any sounds and must be equipped with light dimming device or timer to reduce light intensity based on time of day. The changeable copy on the EMB sign cannot be changed more than one every 7.5 seconds or as established by Federal or State Guidelines, whichever is greater.

*EMB Sign Proposal*

The petitioner proposes replacing the existing two-sided EMB sign with a new larger, two-sided sign in the same location as the current sign as illustrated on the attached Sign Plans. The current sign is surrounded by a wood fence and its base is void of landscaping improvements. However, as part of this request, the petitioner has provided a landscape diagram illustrating the proposed plantings around the sign base outside of the existing fence enclosing the sign base. The table analyzes how the proposed EMB sign aligns with Section 12-11-6.B of the Zoning Ordinance for EMBs for qualified EMB properties. The EMB sign will exceed 500 square feet in area, requiring a major variation.

| EMB Sign for Qualified EMB Property |  |  |                                   |
|-------------------------------------|--|--|-----------------------------------|
| Standard                            | Requirement  | Existing   | Proposed                          |
| Sign Height                         | 45 FT Maximum  | 45 FT  | 45 FT                             |
| Total Sign Area                     | 500 SF Maximum   | 488 SF   | <b>509 SF*</b>                    |
| Sign Quantity                       | Up to One Sign Permitted   | One  | One                               |
| Sign Location                       | Must be located between I-90 or I-294 & structure(s) on site and be screened from all residences | Located between office building & I-90 and is screened from residences | <i>No change to sign location</i> |

\*A major variation is required for the EMB sign area.

<sup>2</sup> Excluding EMB signs embedded within electric vehicle (EV) charging ports and drive-through menu board signs.

<sup>3</sup> Excluding EMB signs embedded within EV charging ports and drive-through menu board signs, which have specific regulations.

## Major Variation

### **Request Summary:**

#### *Overview*

As noted above, the proposed EMB monument sign will be 509 square feet in area, which exceeds the maximum 500-square-foot sign area permitted in Section 12-11-6.B for EMBs on qualified EMB properties. While the sign is screened from residential, the PZB should consider the adverse effects of this sign type on motorists and whether the increase size is feasible in this location.

#### *Consideration of Alternatives*

There are alternatives available that do not require the conditional use and variation application requested:

- Like for Like Replacement of Current Sign: Allows replacement of the current sign size and structure with little to no adjustments.
- Slight Enlargement of Current Sign to Max Area Allowed: Allows an enlargement of the sign to the maximum 500 SF permitted—which is included in the original 2011 approval—for a larger display but primarily same function as the existing sign.

#### *Other Considerations*

In its review of this request, the PZB may also consider the following:

- 2019 Comprehensive Plan: This plan provides general goals and strategies for the implementation of gateway and wayfinding signs throughout the City, especially in the downtown area and specific significant street corridors, to promote uniform identity and reduce visual clutter through sign regulation. *It does not, however, promote or seek to increase the installation and use of EMBs or other signs that could visually clutter along corridors for private property.* As a result, the proposal would not align with a specific goal or strategy of the City’s 2019 Comprehensive Plan.
- City’s Zoning Ordinance: Chapter 11 of the Zoning Ordinance provides comprehensive regulations of signs in the City to:
  - Provide *reasonable yet appropriate conditions* for identifying businesses and services rendered in commercial, institutional and industrial areas;
  - *Reduce traffic hazards by restricting signs and lights which exceed a viewer's capacity to receive information, or which increases the potential for accidents created by signage which distracts or obstructs a viewer's vision*; and
  - *Protecting the health, safety and general welfare* of the residents of the City.

### **Planning and Zoning Board (PZB) Recommendation**

The PZB held a public hearing on April 14, 2026 to consider the request and voted 5-0 to recommend that City Council approve the conditional use and major variation requests with the conditions as written. The rationale for the PZB’s vote is captured in the attached excerpt of minutes from the April 14, 2026 PZB Meeting.

## **City Council Action**

Pursuant to Sections 12-3-4.D.4 and 12-3-6.G.2.c of the Zoning Ordinance, the Council has the final authority on the conditional use and major variation requests. The Council may approve, approve with modifications, or deny Ordinance Z-8-26, which includes the requested conditional use and major variation for the EMB sign on the subject property. If the City Council decides to approve these requests, staff and PZB recommend the following conditions.

### **Conditions of Approval:**

1. A minimum three-foot-wide landscape bed is required to be installed and maintained around the entire sign base. The landscape bed shall be improved with evergreen bushes not less than three feet in height in front of the sign and shorter shrubs and perennials along the fence enclosure around the sign base.
2. At time of the building permit process, the Proposed EMB sign plans may be modified as necessary to comply with all local and state requirements, provided the total sign area is not increased in size beyond the requested 509 square feet.
3. The Proposed EMB must remain in compliance with all requirements for Electronic Message Board Billboards set forth in Section 12-11-6.B of the City Code, including requiring the Petitioners to enter into an agreement with the City regarding the display of City sponsored messages in a form acceptable to the City Manager and the City Attorney.

### **Attachments:**

- Attachment 1: Location Map
- Attachment 2: Site and Context Photos
- Attachment 3: ALTA/ACSM Land Title Survey
- Attachment 4: Ordinance Z-18-11 and Original Approved Sign Permit
- Attachment 5: Petitioner's Responses to Standards
- Attachment 6: Acting Chairman Catalano PZB Recommendation Letter
- Attachment 7: Excerpt of Minutes from the April 14, 2026 PZB Meeting

### **Ordinance Z-8-26**

- Exhibit A: Project Narrative
- Exhibit B: Sign Plan
- Exhibit C: Unconditional Agreement and Consent



0 250 500 ft

Print Date: 4/10/2026

Notes

Disclaimer: The GIS Consortium and MGP Inc. are not liable for any use, misuse, modification or disclosure of any map provided under applicable law. This map is for general information purposes only. Although the information is believed to be generally accurate, errors may exist and the user should independently confirm for accuracy. The map does not constitute a regulatory determination and is not a base for engineering design. A Registered Land Surveyor should be consulted to determine precise location boundaries on the ground.



999 E. Touhy Avenue – Public Notice Sign



999 E. Touhy Avenue – Facing Southeast at Front of Property



999 E. Touhy Avenue – Facing North at Rear of Building



999 E. Touhy Avenue – Facing Southeast at Side Parking Area



999 E. Touhy Avenue – View of Existing EMB Sign Base

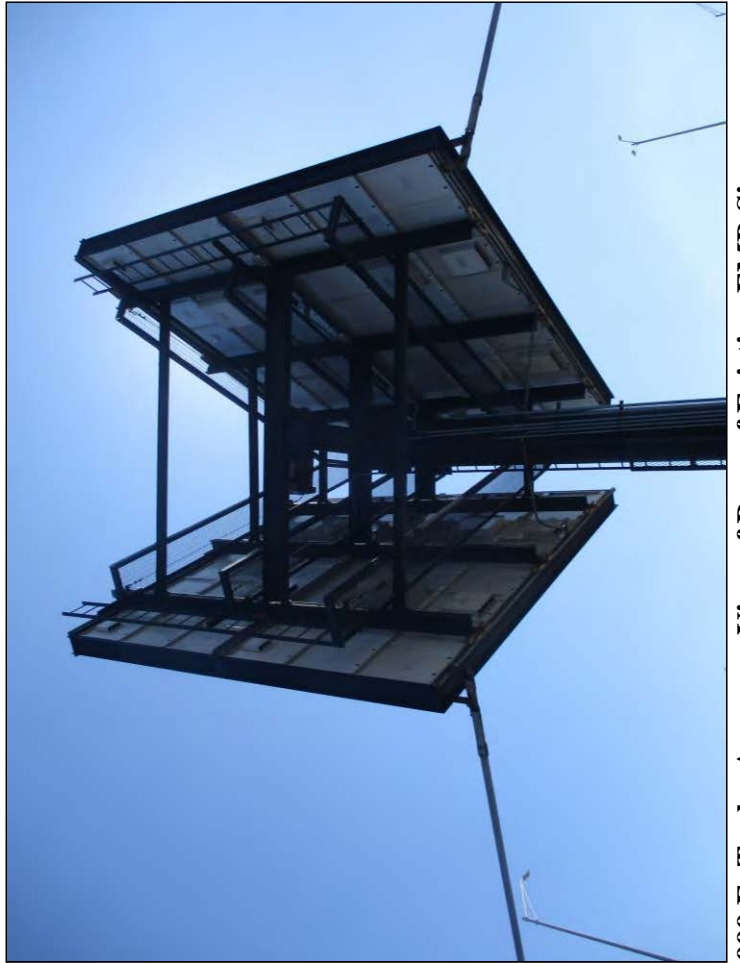

999 E. Touhy Avenue – View of Rear of Existing EMB Sign



999 E. Touhy Avenue – View of Front of Existing EMB Sign



999 E. Touhy Avenue – View of Side of Existing EMB Sign



**CITY OF DES PLAINES**

**ORDINANCE Z - 18 - 11**

**AN ORDINANCE APPROVING A CONDITIONAL USE UNDER SECTION 11.5-7 OF THE CITY OF DES PLAINES ZONING ORDINANCE TO AUTHORIZE A 500 SQUARE FOOT ELECTRONIC MESSAGE BOARD SIGN AT 999 E. TOUHY AVENUE, DES PLAINES, ILLINOIS. (CASE #11-016-CU).**

FILE COPY

**WHEREAS**, application has been made by Patrick J. Devereaux on behalf of ALM 7, LLC and DPM 7, LLC ("Petitioner") for a Conditional Use, under Section 11.5-7 of the City of Des Plaines Zoning Ordinance, to authorize a 500 square foot Electronic Message Board Sign at 999 E. Touhy Avenue, Des Plaines, Illinois; and

**WHEREAS**, the existing zoning is C-2, Limited Office Commercial and the property is a Qualified EMB Property; and

**WHEREAS**, within fifteen (15) days of the receipt thereof, said application was referred by the Department of Community Development to the Zoning Board of Appeals of the City of Des Plaines; and

**WHEREAS**, within ninety (90) days from the date of said application a public hearing was held by the Zoning Board of Appeals on May 31, 2011 pursuant to publication in the Des Plaines Journal and Topics on May 13, 2011 and notice was mailed to all property owners within 300 feet of the subject property of the consideration of the Conditional Use Permit so proposed by the Applicant; and

**WHEREAS**, said hearing of the Zoning Board of Appeals was held pursuant to notice published as required by law, wherein competent testimony and evidence was given with respect to how said applicant intended to meet the provisions of the Zoning Ordinance, and said Zoning Board of Appeals filed a written report of such testimony and evidence and their recommendations unanimously approving thereon to the City Council on May 31, 2011; and

**WHEREAS**, said applicant made certain commitments to the Zoning Board of Appeals with respect to the requested Conditional Use Permit, which representations are hereby found by the City Council to be material and upon which the City Council relies in granting this request for a Conditional Use Permit subject to certain terms and conditions; and

**WHEREAS**, the City Council has studied the respective written reports of the Zoning Board of Appeals, together with the applicable standards set forth in the Zoning Ordinance, the Staff Report dated June 1, 2011, including the Conditional Use Application completed by the Petitioner, together with the exhibits to the Staff Report, which include a Land Title Survey, a Signage Package, a Location Map, Site and Context Photos, a Plan of Operation, Ordinance Z-10-11, the Draft Minutes of the Zoning Board of Appeals, dated May 31, 2011, and the Letter

B. The approval of a proposed conditional use permit by the City Council shall be deemed to authorize only that particular use at that particular location for which the conditional use was issued.

C. Except when otherwise provided for in this Ordinance, a conditional use shall be deemed to relate to, and be for the benefit of, the use and lot in question, rather than the owner or operator of such use or lot.

3.4-9: The approval of a conditional use permit application by the City Council shall not authorize the development, construction, reconstruction, alteration or moving of any building or structure, but shall merely authorize the preparation, filing and processing of applications for such permits or approvals as may be required by the regulations of the City, including but not limited to a Zoning Certificate and a building permit.

**SECTION 4:** That the property located at 999 E. Touhy Avenue, Des Plaines, Illinois,

which is the subject of this Ordinance is legally described as follows:

PARCEL 1:

LOT 1 IN O'HARE NORTH WEST OFFICE PARK SUBDIVISION, A SUBDIVISION OF PART OF THE NORTHWEST ¼ OF SECTION 32, TOWNSHIP 41 NORTH, RANGE 12, EAST OF THE THIRD PRINCIPAL MERIDIAN, IN COOK COUNTY, ILLINOIS.

PARCEL 2:

EASEMENT FOR INGRESS AND EGRESS FOR THE BENEFIT OF PARCEL 1, AS CREATED BY AGREEMENT DATED DECEMBER 12, 1975 MADE BY AND BETWEEN LASALLE NATIONAL BANK, AS TRUSTEE UNDER TRUST NUMBER 48605 (GRANTOR), FIRST CHICAGO REALTY SERVICES CORPORATION (MORTGAGEE), AND LASALLE NATIONAL BANK, AS TRUSTEE UNDER TRUST NUMBER 46595 (GRANTEE), RECORDED DECEMBER 16, 1975 AS DOCUMENT 23325794, OVER AND ACROSS THE FOLLOWING:

THE NORTH 60.0 FEET, AS MEASURED AT RIGHT ANGLES AND CONCENTRIC WITH THE NORTHERLY LINE, OF THE FOLLOWING DESCRIBED TRACT OF LAND:

THAT PART OF THE NORTH 2/3 OF THE EAST ½ OF THE NORTHEAST ¼ OF THE NORTHWEST ¼ OF SECTION 32, TOWNSHIP 41 NORTH RANGE 12, EAST OF THE THIRD PRINCIPAL MERIDIAN, LYING SOUTHERLY OF THE FOLLOWING DESCRIBED LINE:

BEGINNING AT A POINT ON THE WEST LINE OF THE EAST ½ OF THE NORTHEAST ¼ OF THE NORTHWEST ¼ OF SECTION 32 AFORESAID, A DISTANCE OF 634.43 FEET SOUTH OF THE NORTHWEST CORNER THEREOF, (SAID WEST LINE HAVING A BEARING OF SOUTH 00 DEGREE, 14 MINUTES, 58 SECONDS WEST FOR THE PURPOSES OF THIS DESCRIPTION); THENCE NORTH 88 DEGREES, 32 MINUTES, 18 SECONDS EAST, A DISTANCE OF 157.28 FEET TO A POINT ON A CURVE HAVING A RADIUS OF 576.94 FEET AND BEING CONCAVE TO THE NORTHWEST; THENCE NORTHEASTERLY ALONG SAID CURVE (THE CHORD OF SAID CURVE BEARING NORTH 58 DEGREES, 48 MINUTES, 38 SECONDS EAST, A DISTANCE OF 390.77 FEET), AND ARC DISTANCE OF 398.65 FEET TO A POINT ON ANOTHER CURVE, WHICH HAS A RADIUS OF 490.0 FEET AND BEING CONCAVE TO THE SOUTHWEST, SAID POINT BEING 2.78 FEET SOUTHEASTERLY, ( AS MEASURED ALONG THE ARC OF SAID CURVE FROM A POINT) WHICH LIES 444.0 FEET SOUTH, (AS MEASURED AT RIGHT ANGLES) FROM THE NORTH LINE OF SAID NORTHWEST ¼ OF SECTION 32 AND 175.0 FEET WEST, (AS MEASURED AT RIGHT ANGLES ) FROM THE EAST LINE OF SAID NORTHWEST ¼ OF SECTION 32 AND LYING WESTERLY OF THE FOLLOWING DESCRIBED LINE:

COMMENCING AT A POINT OF INTERSECTION OF THE SOUTH LINE OF THE NORTH 2/3 OF THE NORTHEAST ¼ OF THE NORTHWEST ¼ OF SECTION 32, WITH THE WESTERLY LINE OF THE RIGHT OF WAY OF THE ILLINOIS STATE TOLL HIGHWAY COMMISSION, WHICH WAS ACQUIRED BY CONDEMNATION FILED AS CASE NO. 57-S-1501; THENCE NORTH 00 DEGREE, 17 MINUTES EAST

STRIP OF LAND IN LOT 2 IN O'HARE NORTHEAST OFFICE PARK SUBDIVISION, AFORESAID, IN COOK COUNTY, ILLINOIS.

PARCEL 5:

EASEMENT FOR THE BENEFIT OF PARCEL 1 FOR PEDESTRIAN AND VEHICULAR TRAFFIC OVER, ACROSS, AND UPON ALL STREETS, ROADS, ALLEYS, AND WAYS NOW OR HEREAFTER LOCATED, AND FOR PARKING UPON ALL PUBLIC PARKING AREAS NOW OR HEREAFTER LOCATED ON THE PORTION OF TRACT A DESCRIBED ON EXHIBIT C ATTACHED THERETO, AS CREATED BY A RECIPROCAL EASEMENT AGREEMENT RECORDED MARCH 29, 1976 AS DOCUMENT 23432344, IN COOK COUNTY ILLINOIS.

PINs: 09-32-101-019-0000  
09-32-101-022-0000

09-32-101-020-0000  
09-32-101-023-0000

09-32-101-021-0000

**SECTION 5:** That granting of the Conditional Use Permit for the subject property is granted upon the conditions set forth below. Upon failure of the Petitioner to act upon this authorization within twelve (12) months of the date of this Ordinance, the granting of the Conditional Use Permit for the subject property shall be automatically revoked; provided, however, that upon request in writing of the Petitioner prior to the expiration of the twelve (12) month period, the City Council may at any time, or from time to time by ordinance duly adopted at any meeting of the City Council, extend said period of time. In addition to the foregoing and the requirements of 11.5-7 and 11.6 B of the Zoning Code, the Petitioner must meet the following conditions:

1. The proposed Electronic Message Board signs shall conform to all Des Plaines Zoning Ordinance regulations regarding operational characteristics such as permitted and prohibited types of Electronic Message Boards, interval of message, brightness of signs.
2. Automatic Dimming. Electronic multiple message signs shall be equipped with light sensing devices or a scheduled dimming timer which automatically dims the intensity of the light emitted by the sign during ambient low-light and nighttime (dusk to dawn) conditions. The signs shall not exceed five hundred (500) nits of intensity as measured at the sign surface during nighttime and low-light conditions and five thousand (5,000) nits during daytime hours.
3. The operator of the Electronic Message Board agrees to permit the City to post messages, including public service announcements, Amber Alerts and City information to be displayed no less than 3.5% of the total time the Electronic Message Board is operating in any 24 hour period. City messages will be displayed throughout such 24 hour period, with the majority of the display occurrences taking place during the periods from 5 a.m. to 11 a.m. and 1 p.m. to 9 p.m., unless the City requests a different over-night or middle of the night distribution. Notwithstanding the foregoing and without the consent of the City, the operator may cease displaying any announcements which may be outdated or superseded.

**SECTION 8:** That within 60 days of the passage of said Ordinance, the executed, original Ordinance shall be returned to the City Clerk's office.

**SECTION 9:** If any paragraph, section, clause or provision of this ordinance is held invalid, the remainder shall continue in full force and effect without affecting the validity of the remaining portions of the contract.

**SECTION 10:** That this Ordinance shall be in full force and effect from and after its passage, approval and publication in pamphlet form according to law.

PASSED this 20<sup>th</sup> day of June, 2011.

APPROVED this 20<sup>th</sup> day of June, 2011.

VOTE: AYES 8 NAYS 0 ABSENT 0

  
MAYOR

ATTEST:

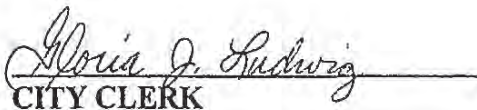
  
CITY CLERK

Published in pamphlet form this  
20<sup>th</sup> day of June, 2011.

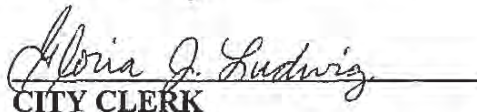
  
CITY CLERK

Approved as to form:

  
David R. Wiltse, City Attorney

ALM 7, LLC and DPM 7, LLC, being the owner or other party in interest of the property, legally described within this Ordinance, having read a copy of the Ordinance, do hereby accept, concur and agree to develop and use the subject property in accordance with the terms of this Ordinance.

Dated: 6/27/2011

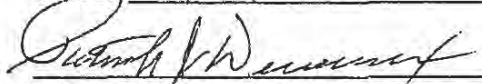
 (Signature)  
ALM 7, LLC and DPM 7, LLC  
By its authorized representative

LegalOrd\Special\CU 999 Touhy Sign

DATE RECEIVED 2-29-2012  
DATE ISSUED \_\_\_\_\_  
PERMIT NO. 12020118

# APPLICATION FOR SIGN PERMIT

SIGN ADDRESS 999 E Touhy Ave.  
OWNER (LESSEE) Siete 7, LLC ADDRESS 999 E Touhy Ave ZIP \_\_\_\_\_ TEL \_\_\_\_\_  
MANUFACTURER Landmark Sign Group ADDRESS \_\_\_\_\_ ZIP \_\_\_\_\_ TEL \_\_\_\_\_  
INSTALLER SAME ADDRESS \_\_\_\_\_ ZIP \_\_\_\_\_ TEL \_\_\_\_\_  
ELECTRICAL CONTRACTOR Aulinger Electric ADDRESS \_\_\_\_\_ ZIP \_\_\_\_\_ TEL \_\_\_\_\_

TYPE OF SIGN

- POLE
- ILLUMINATED
- RE-FACE
- TEMPORARY
- MONUMENT
- SINGLE FACED
- BANNER
- TENSILE
- WALL
- DOUBLE FACED
- AWNING
- DATE LAST TEMPORARY SIGN \_\_\_\_\_

UNLESS VOID  
RECEIVED  
BY CASHIER

BUILDING FRONTAGE 232' LOT FRONTAGE 672' SETBACK REQUIREMENTS 37'-3"

DESCRIPTION OF SIGN

DIMENSIONS OF SIGN: 21'-8" x 22'-6 1/2" HEIGHT ABOVE GROUND: 45'  
MATERIAL(S): LED Technology within Steel & Aluminum Cabinet TOTAL SQUARE FEET (ALL SIDES): 488  
DESCRIPTION AND SQUARE FOOTAGE OF EXISTING SIGNS: Existing sign being removed  
TEMPORARY SIGN TIME LIMIT FROM: \_\_\_\_\_ TO: \_\_\_\_\_

ADDITIONAL INFORMATION

Per Ordinance Z-18-11  
Case # 11-016-C4

RECEIVED

FEB 29 2012

\* Existing "blacked out" westmost pole sign shall be removed at time of installation.

BUILDING DEPT.

| CITY OF DES PLAINES 2012 FEES |            |
|-------------------------------|------------|
| REFUNDABLE BOND               | _____      |
| TEMPORARY SIGN FEE            | \$10       |
| STANDARD SIGN FEE             | \$50       |
| SQ. FOOTAGE FEE               | \$244      |
| ELECTRICAL FEE                | \$50       |
| TOTAL FEE                     | \$354.00 ✓ |

FILED BY Landmark Sign Group - Shaun O'Brien APPROVED THIS 2nd DAY OF February 20 12  
ADDRESS \_\_\_\_\_  
CITY Chesterton STATE IN ZIP 46304

PHONE ( \_\_\_\_\_ ) BY [Signature] PERMIT COORDINATOR  
3-5-12 Attachment 4 called for pickup. Page 14 of 63



# Illinois Department of Transportation

Division of Highways / Bureau of Land Acquisition  
2300 South Dirksen Parkway, Springfield, Illinois 62764

February 23, 2012

CERTIFIED MAIL

Siete 7, LLC  
Attn: Mr. Patrick J. Devereaux  
999 E. Touhy Avenue, Suite 130  
Des Plaines, Illinois 60018

**RE: NOTICE OF PERMIT APPROVAL**

Route: I-90  
Location: Des Plaines  
County: Cook

Dear Mr. Devereaux:

This is to notify you that the applications you submitted for outdoor advertising signs to be located in Des Plaines, Illinois have been approved. A copy of the approved permit applications, assigned Permit Nos. [REDACTED] are enclosed for your files.

This approval is contingent upon the prior removal of the "brown" sign. The Department, however, agrees to your proposal that the "brown" sign be removed when the LED sign is erected. With respect to the LED sign, you must ensure that the multiple message feature meets the requirements for multiple message signs (as defined in Section 522.20). In addition, you must ensure that your messages only pertain to activities that are conducted on-premise. Please contact this office at [REDACTED] once the signs have been erected. After receiving notification, and upon assessing compliance, the Department will place approved tags on the signs.

If you have any questions or need additional information, please contact Tim Hoesli, Outdoor Advertising Program Manager, at the telephone number listed above.

Sincerely,

Handwritten signature of Cheryl L. Cathey in black ink.

Cheryl L. Cathey, P.E.  
Acting Bureau Chief of Land Acquisition

Handwritten signature of Tim Hoesli in black ink.

By Tim Hoesli  
Outdoor Advertising Program Manager

Enclosure:

Copy of Approved Application  
cc: File



Application for Outdoor Advertising Permit  
On-Premise Sign - Interstate Highway

Ownership

Permit No. 016-21749

Owner of Proposed Sign Slate 7, LLC

Address 999 E. Touhy Avenue Des Plaines IL 60018 [Redacted]  
(Street) (City) (State) (Zip Code) (Telephone)

Owner of Land Slate 7, LLC

Address 999 E. Touhy Avenue Des Plaines IL 60018 [Redacted]  
(Street) (City) (State) (Zip Code) (Telephone)

Proposed Sign Location

County Cook Marked Route No. Interstate 80

Sign will be located 1,246  feet  mile/miles N of D'Hare International Airport property line  
(NSEW) (Landmark)

37  feet  mile/miles from the N of the highway right-of-way.  
(NSEW)

GPS Coordinates in decimal format: 42.008047 42°0' - 28.9686" latitude (eq. 37.2860370)  
-87.898983 87° - 53' - 56.3388" longitude (eq. -89.4820425)

For signs located within incorporated limits, provide the following:

Name of town Des Plaines, IL

Present zoning classification C-2

Was site within incorporated limits on September 21, 1959?  Yes  No

If no, what was the zoning classification on September 21, 1959? R-4

For signs located outside incorporated limits, provide the following:

Present Zoning Classification N/A

Zoning Classification on September 21, 1959 \_\_\_\_\_

Will sign be located more than 50 feet from the activity advertised?  Yes  No

Description of Proposed Sign

Size: Width 22'-6 1/2" feet Height 45' feet

Will sign have lighting?  No  Yes If yes, what type: LED

Will lights be flashing, intermittent, or moving?  No  Yes

If yes, please describe: Message will be static for period of time and have an instant change

Will sign be other than rectangular?  No  Yes If yes, attach a sketch.



**Illinois Department of Transportation**

**Application for Outdoor Advertising Permit  
On-Premise Sign - Interstate Highway**

**BUREAU OF  
LAND ACQUISITION**

**Ownership**

Permit No. 016-21867

Owner of Proposed Sign Siete 7, LLC 2011 DEC 29 AM 10 04

Address 999 E. Touhy Avenue Des Plaines IL 60018 [REDACTED]  
(Street) (City) (State) (Zip Code) (Telephone)

Owner of Land Siete 7, LLC

Address 999 E. Touhy Avenue Des Plaines IL 60018 [REDACTED]  
(Street) (City) (State) (Zip Code) (Telephone)

**Proposed Sign Location**

County Cook Marked Route No. Interstate 90

Sign will be located 1,246  feet  mile/miles N of O'Hare International Airport property line  
(NSEW) (Landmark)

37  feet  mile/miles from the N of the highway right-of-way.  
(NSEW)

GPS Coordinates in decimal format: 42.007485 latitude (eg. 37.2960370)  
-87.896955 longitude (eg. -89.4820425)

**For signs located within incorporated limits, provide the following:**

Name of town Des Plaines, IL

Present zoning classification C-2

Was site within incorporated limits on September 21, 1959?  Yes  No

If no, what was the zoning classification on September 21, 1959? R-4

**For signs located outside incorporated limits, provide the following:**

Present Zoning Classification N/A

Zoning Classification on September 21, 1959 \_\_\_\_\_

Will sign be located more than 50 feet from the activity advertised?  Yes  No

**Description of Proposed Sign**

Size: Width 14' 8" feet Height 11' 0" feet

Will sign have lighting?  No  Yes If yes, what type: fluorescent lighting

Will lights be flashing, intermittent, or moving?  No  Yes

If yes, please describe: \_\_\_\_\_

Will sign be other than rectangular?  No  Yes If yes, attach a sketch.

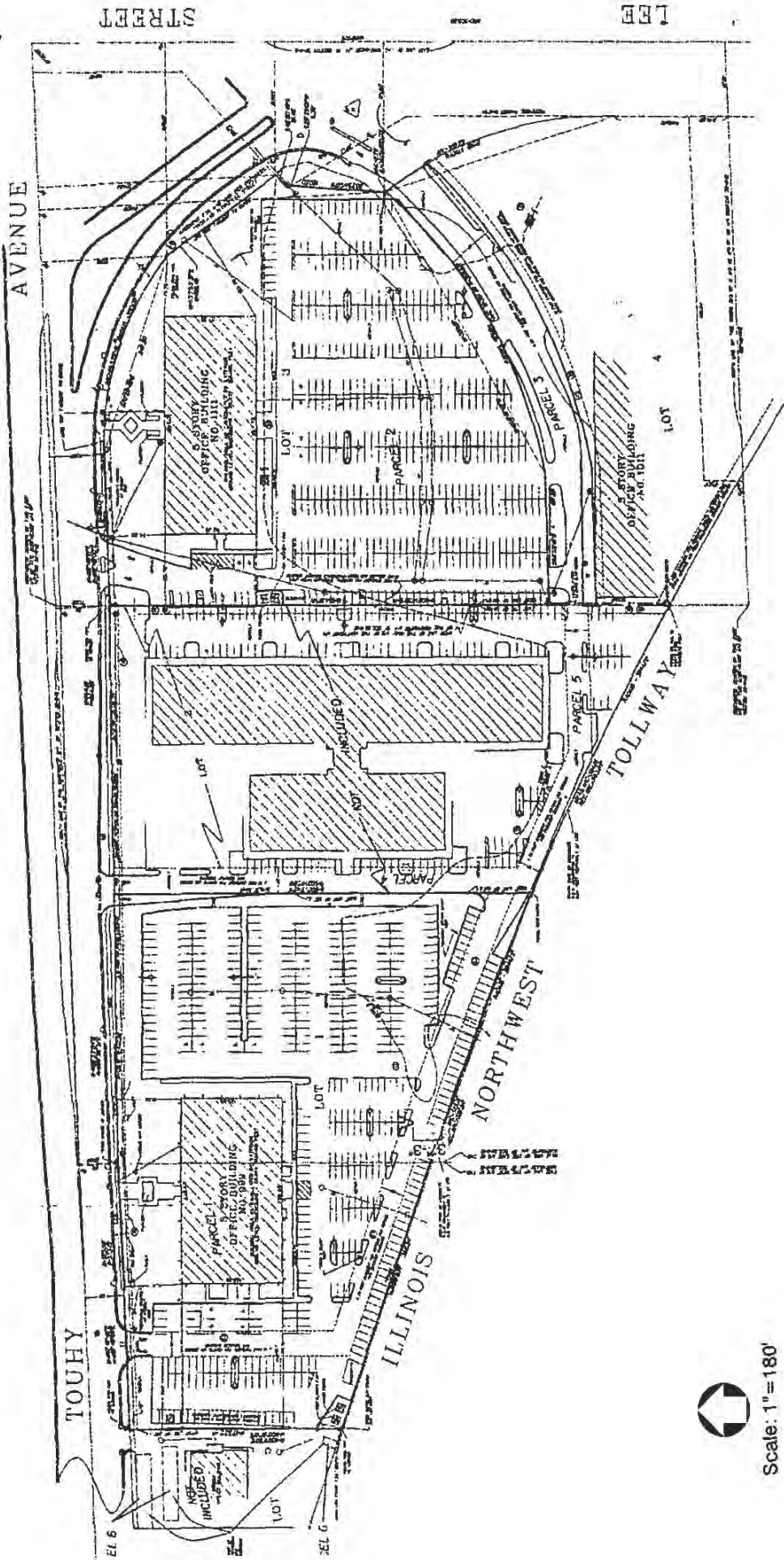

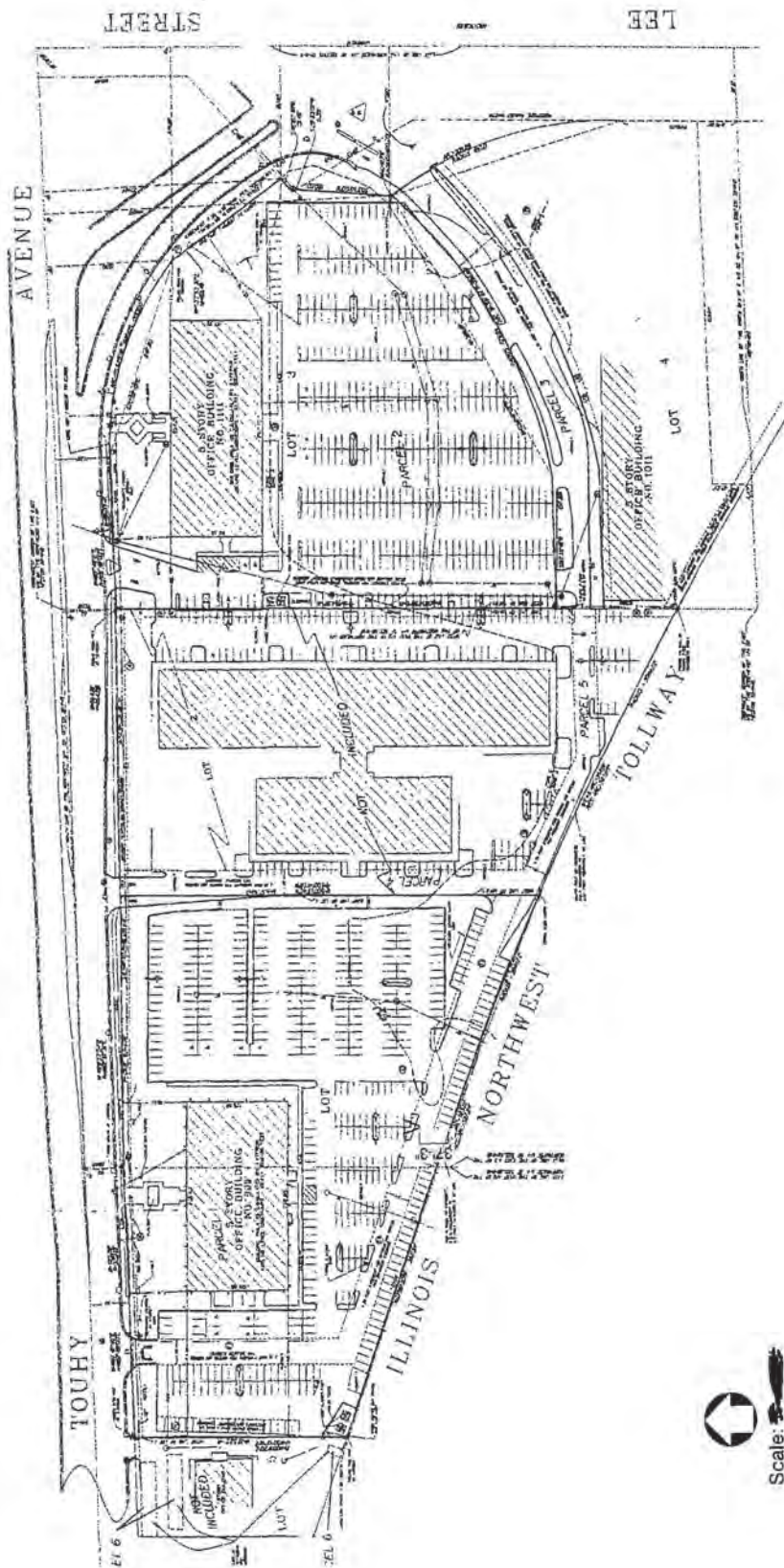

**Designed for 110 volts**  
 Electrical Connection will be visible within 5 Ft. at time of installation.  
 Second Trip will be charged at time of Material

THIS DRAWING IS THE PROPERTY OF LANDMARK SIGN GROUP, INC. NO REPRODUCTIONS OR EXEMPTIONS ARE PERMITTED WITHOUT THE WRITTEN CONSENT OF LANDMARK SIGN GROUP, INC. AN ASSURANCE OF UP TO \$10,000.00 WILL BE CHARGED FOR ANY VIOLATION OF THIS POLICY.

**LAN** L.S.G. SALES INITIALS

**Customer Acceptance SIGNATURE** DATE

**Customer Acceptance SIGNATURE** DATE

**Customer Acceptance SIGNATURE** DATE

**Customer Acceptance SIGNATURE** DATE

**Customer Acceptance SIGNATURE** DATE

**Customer Acceptance SIGNATURE** DATE

**Customer Acceptance SIGNATURE** DATE

**Customer Acceptance SIGNATURE** DATE

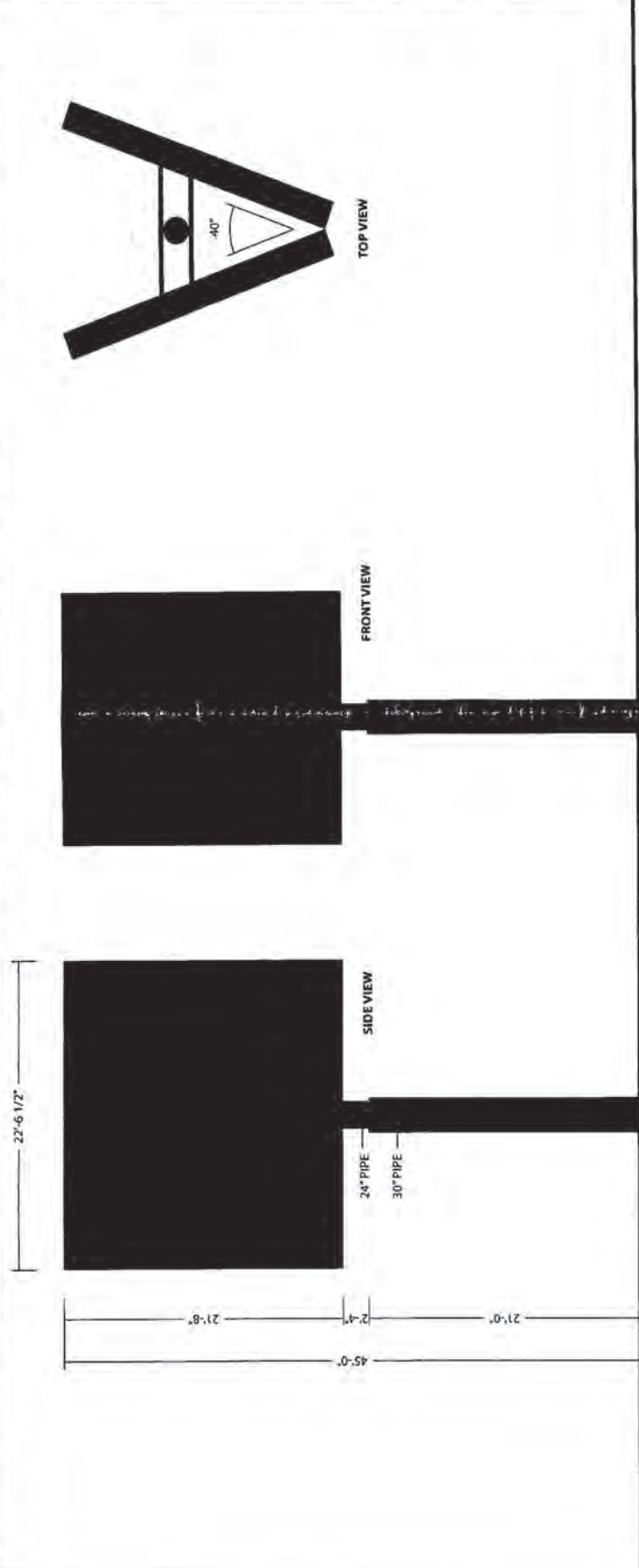

▲ TWO (2) SINGLE FACE LED ELECTRONIC DISPLAY UNITS / MOUNTED IN V-SHAPE TO STEEL POLE

○ MATRIX = 16mm 400 x 416 FULL COLOR  
 ACTIVE AREA = 21'-8" x 22'-6 1/2" (488.2 SQUARE FEET)

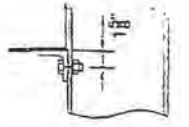

SECTION T-T  
S.F.S.

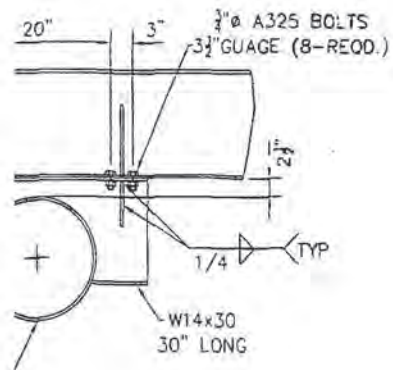

BEAM, SLEEVE TORSION  
D WELD ALL AROUND  
TAIL K  
N.T.S.

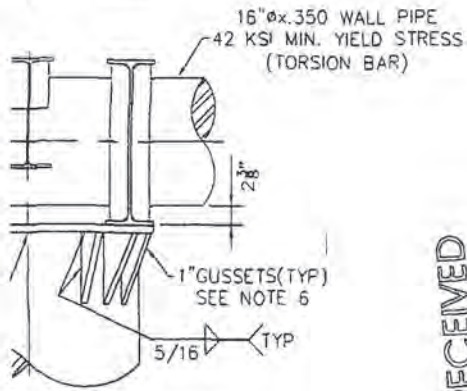
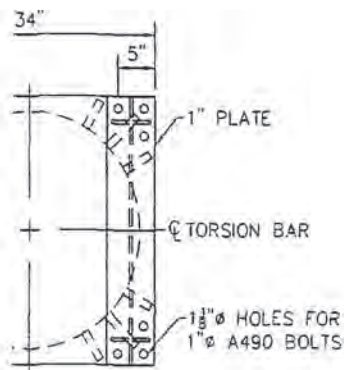

BEAM, SLEEVE TORSION  
D 1/4 FILLET ALL AROUND  
TAIL B  
N.T.S.

RECEIVED  
 FEB 29 2012  
 BUILDING DEPT.

SAND OR BETTER. (Allowable soil pressure=200p.s.f./ft. of depth).  
 CONTRACTOR TO NOTIFY ENGINEER IF OTHER THAN THESE SOIL  
 CONDITIONS EXIST.  
 4) ATTACH CATWALK ANGLES USING 1/4" O A-325 BOLT (1 / ANGLE).  
 5) CATWALK GRATING TO BE 3.14 PSF EXPANDED METAL GRATING,  
 WELDED WITH 1/4" FILLET, 1" LONG @ 12" O/C TO ANGLE.  
 6) PLACE GUSSETS AS CLOSE TO HOLES AS POSSIBLE ALLOWING  
 FOR BOLT TIGHTENING.

**TYPICAL GUSSET DETAIL**

(Use this criteria for all gussets).

-Length & height of gussets to be determined by fabricator if not specified. Use maximum length & height possible & still allow for welding all around.  
 -depth of 45° chamfer to be minimum required to clear weld or fillet.

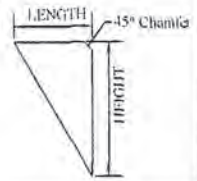

**GENERAL NOTES**

- All nuts and bolts are to be zinc plated. (Except A-490 bolts which are not to be plated, but primed and painted after installation).
- The contractor shall verify all dimensions and conditions in the field before fabrication or construction, and notify engineer of any discrepancies.
- Any deviations from this print must be approved by Engineer.
- All structural steel shall conform to the requirements of ASTM A-36 (Except structural tubing, which shall conform to A-500 grade B).
- All W-shape beams shall conform to A-572 (50 ksi minimum yield).
- All steel pipe shall conform to the requirements of ASTM A-53 grade B or A-252 grade 2, unless otherwise noted.
- Concrete shall attain a minimum compressive strength of  $f'_c = 3000$  psi in 28 days, unless otherwise noted.
- All structural steel shall be produced, fabricated, and erected according to latest AISC Specifications and Standard Practice.
- All welding shall be in accordance with AWS Standards. Welding to be performed by certified welders using E-70 electrodes.
- Contractor to ensure that all work is performed in accordance with federal, state, and local codes & ordinances; and OSHA safety regulations.
- Splicing of pipes having an equal diameter, wall & yield is permitted. A full penetration weld all around (Per AWS D1.1) shall be used and must be performed by a certified welder. Splices shall not be: within one half of the foundation depth below grade, within 10' above grade or within 10' above telescoping splices. Unless specified otherwise.

THE UNDER SIGNED ENGINEER WILL NOT SUPERVISE THE FABRICATION AND/OR ERECTION OF THIS STRUCTURE.

**APPLICABLE BUILDING CODE AND WIND SPEED:**

*International Building Code (2006/2009 Edition)*  
 (90 mph Exposure-C) 3-Second Gusts

**PROJECT**

22'-0" x 23'-0" CM, 40°V @ 45'-0" O.A.H.  
 w/(2)-7,590# L.E.D. Units  
 Located in Des Plaines, IL



Effective Engineering Solutions, L  
 61 White Water Court  
 New Lenox, IL 60451  
 (815) 485-1470

**AFFIX SEAL**

THIS PRINT CONTAINS PROPRIETARY INFORMATION AND SHALL NOT BE USED, REPRODUCED, OR ITS CONTENTS DISCLOSED IN WHOLE OR IN PART, WITHOUT WRITTEN CONSENT FROM

Effective Engineering Solutions, Ltd.

**REVISIONS**

|              |            |
|--------------|------------|
| DRAWN BY:    | JNG        |
| DATE DRAWN:  | 10-26-11   |
| SCALE:       | N/A        |
| SELECTIVE E: | Permitting |
| DRAWING #:   | SS-6076    |
| SHEET #:     | 1 OF 1     |



*Clifford W. Leverenz*  
 OCT 31 2011

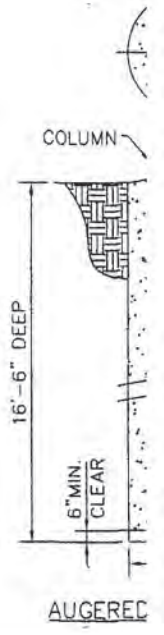
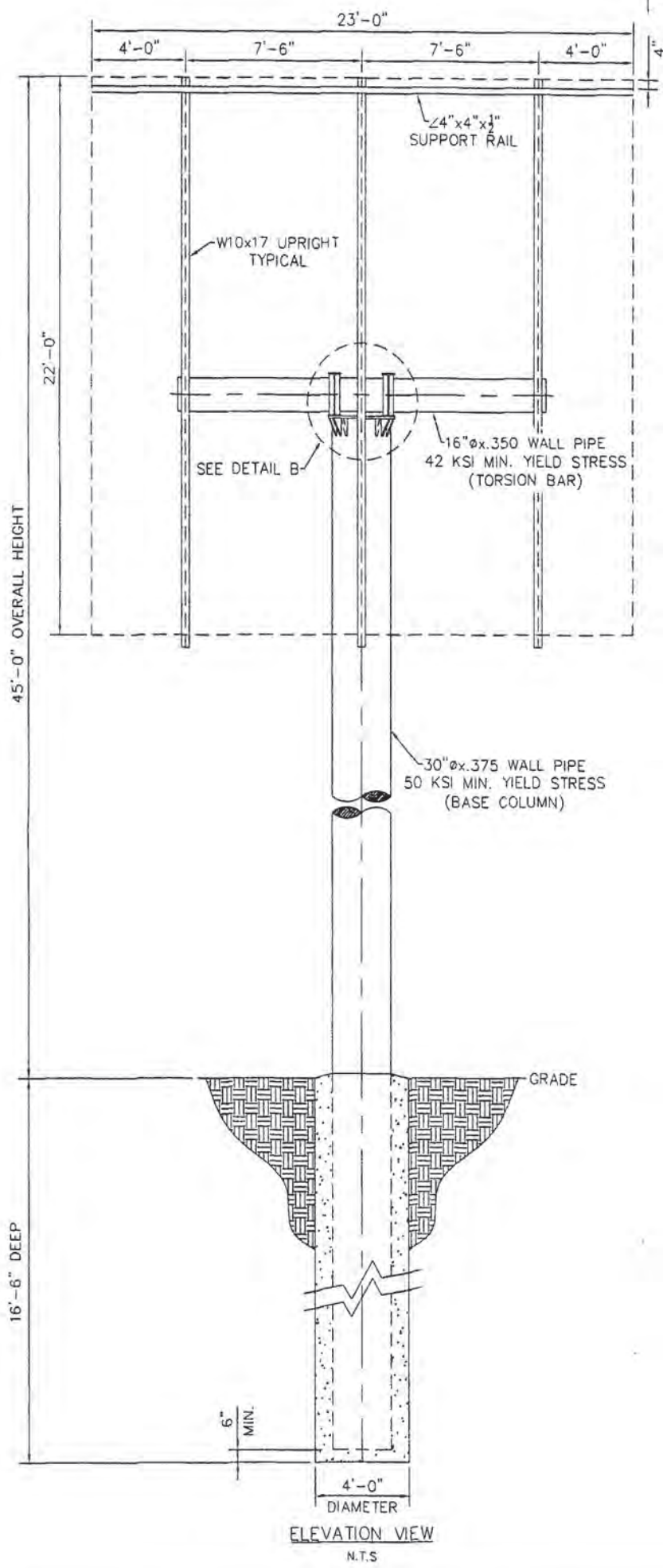

## STANDARDS FOR CONDITIONAL USES

**The Planning and Zoning Board and City Council review the particular facts and circumstances of each proposed Conditional Use in terms of the following standards.** Keep in mind that in responding to the items below, you are demonstrating that the proposed use is appropriate for the site and will not have a negative impact on surrounding properties and the community. Please answer each item completely and thoroughly (two to three sentences each).

1. The proposed conditional use is in fact a conditional use established within the specific zoning district involved;

-The request for additional square footage is a conditional use established within the C-2 Zoning District. The new EMB unit is allowed under certain conditions through conditional use pursuant to section 12-11-5.G.7 of the Des Plaines Zoning Ordinance. The sign replacement and request for additional square footage will remain compliant with the district's designated guidelines.

2. The proposed conditional use is in accordance with the objectives of the city's comprehensive plan and this title;

-The proposed sign replacement request, including the application for additional square footage beyond what is typically permitted, has been thoroughly designed and found to be in alignment with the City's comprehensive planning documents. The new sign will align within the economic development mission statement in relation to vibrant commercial sectors. The sign will be modern and bring vibrancy to the area.

3. The proposed conditional use is designed, constructed, operated, and maintained so as to be harmonious and appropriate in appearance with the existing or intended character of the general vicinity;

-The proposed signage replacement will not alter the character of the surrounding area. The sign will incorporate only minimal additional square footage, which will preserve the current style and appearance of the existing sign. The replacement is primarily an upgrade for safety and maintenance, addressing a nonfunctioning unit.

4. The proposed conditional use is not hazardous or disturbing to existing neighboring uses;

- The proposed conditional use will not be hazardous or disruptive to the neighboring area. The additional square footage of the digital sign constitutes a modern replacement that will mitigate the hazardous condition of the existing sign non-functioning sign. The illumination of the sign, in regard to brightness, scheduled illumination and pace of the changing display, will be per sign code to avoid disturbance within the surrounding areas and roadways. The replacement will not adversely affect the neighboring area.

5. The proposed conditional use is to be served adequately by essential public facilities and services such as highways, streets, police and fire protection, drainage structures, refuse disposal, water and sewer, and schools; or the persons or agencies responsible for the establishment of the proposed conditional use shall provide adequately any such services;

- The proposed conditional use of the sign will be adequately served by any necessary essential services. The minor increase in the sign's square footage will not alter the service requirements for the sign or the associated establishment.

6. The proposed conditional use does not create excessive additional requirements at public expense for public facilities and services and not be detrimental to the economic welfare of the community;

- The proposed conditional use will not generate additional expenses or impose new requirements upon the public. Furthermore, the increase in square footage for the existing signage is not anticipated to negatively affect the economic welfare of the community.

7. The proposed conditional use does not involve uses, activities, processes, materials, equipment and conditions of operation that will be detrimental to any persons, property, or the general welfare by reason of excessive production of traffic, noise, smoke, fumes, glare or odors;

-The replacement of the digital sign display unit will not be detrimental to the property or to any person in its vicinity. This replacement will rectify the current sign issues, which result in monthly display outages until maintenance is performed. Additionally, the unit replacement will be made with a Ledman LED model, which saves 25% more energy than traditional display units. The sign replacement will yield a properly functioning unit, eliminating the distraction and operational issues currently experienced by the establishment.

8. The proposed conditional use provides vehicular access to the property designed that does not create an interference with traffic on surrounding public thoroughfares;

-The sign replacement will be limited solely to the digital sign component. The existing base and foundation of the sign will remain unaltered, ensuring no disruption to the flow of traffic within the parking lot or on the adjacent street.

9. The proposed conditional use does not result in the destruction, loss, or damage of a natural, scenic, or historic feature of major importance; and

-The proposed conditional use is not anticipated to negatively influence the surrounding area. The location and height of the existing sign will remain unchanged, thereby ensuring no physical alteration to its foundation or visual impact.

10. The proposed conditional use complies with all additional regulations in this title specific to the conditional use requested

A major variation request and subsequent approval are necessary because the replacement sign exceeds the maximum allowable sign area. Nonetheless, we will ensure strict compliance with all other sign specifications as outlined in the City of Des Plaines ordinances.

## STANDARDS FOR VARIATIONS

**In order to understand your reasons for requesting a variation, please answer the following items completely and thoroughly (two to three sentences each).** Variation applicants must demonstrate that special circumstances or unusual conditions prevent them from following the specific regulations of their zoning district. Applicants must prove that the zoning regulations, in combination with the uncommon conditions of the property, prevents them from making any reasonable use of the land. Keep in mind that no variation may be granted that would adversely affect surrounding properties or the general neighborhood.

1. **Hardship:** No variation shall be granted pursuant to this subsection H unless the applicant shall establish that carrying out the strict letter of the provisions of this title would create a particular hardship or a practical difficulty.

-The Hardship/difficulty has been created simply because the existing sign requires replacement due to the malfunctioning illumination, which presents an issue since the current digital display is experiencing intermittent failure because of outdated components. As a result since Siete 7 will be using a different sign manufacturer, the size of the unit will vary slightly, posing a need for a larger sign. The replacement sign will feature minor dimensional adjustments as a result of variances in the manufacturing specifications for digital cabinets. Specifically, the new sign will necessitate an increase in size—approximately 19.89 square feet per side—to ensure optimal functionality of the digital display.

2. **Unique Physical Condition:** The subject lot is exceptional as compared to other lots subject to the same provision by reason of a unique physical condition, including presence of an existing use, structure, or sign, whether conforming or nonconforming; irregular or substandard shape or size; exceptional topographical features; or other extraordinary physical conditions peculiar to and inherent in the subject lot that amount to more than a mere inconvenience to the owner and that relate to or arise out of the lot rather than the personal situation of the current owner of the lot.

The sign has been a familiar fixture in Des Plaines, visible to passing vehicles on I-90, since 2012. This Sign location is unique because it involves replacing the existing unit with a new one on the same foundation, rather than installing a new sign.

To ensure the sign remains in good condition and maintains its originally intended placement, maintenance is necessary. Given its long-standing familiarity in the area, it is crucial to retain the original signage and the requested square footage at this location. This continuity ensures optimal visibility for vehicular traffic on the roadway.

3. **Not Self-Created:** The aforesaid unique physical condition is not the result of any action or inaction of the owner or its predecessors in title and existed at the time of the enactment of the provisions from which a variance is sought or was created by natural forces or was the result of governmental action, other than the adoption of this title.

-The pursuance of a larger EMB sign is not a self-created hardship given the wide range of sign sizes available. The existing digital sign requires replacement due to normal wear and tear. As sign manufacturers' specifications vary slightly, replacing the unit with a modern alternative will result in a minor increase in size.

4. **Denied Substantial Rights:** The carrying out of the strict letter of the provision from which a variance is sought would deprive the owner of the subject lot of substantial rights commonly enjoyed by owners of other lots subject to the same provision.

-Denying the variation would result in the loss of substantial rights. Siete 7 LLC has a vested right to proceed with development because they have already made significant, good-faith expenditures in reliance on approved building permits. This right protects them from subsequent alterations to the zoning ordinances. The minimal increase in square footage is exclusively needed to accommodate the slightly larger size of the replacement for the existing, limited-capacity digital display.

5. Not Merely Special Privilege: The alleged hardship or difficulty is neither merely the inability of the owner or occupant to enjoy some special privilege or additional right not available to owners or occupants of other lots subject to the same provision, nor merely the inability of the owner to make more money from the use of the subject lot.

The proposed replacement and minimal square footage addition are necessary solely to repair and restore the sign's digital components to operational status for the foreseeable future. This modification is not an appeal for special privilege to increase business revenue, but rather a necessity to ensure the sign remains in proper working condition. Due to the updated technology of the modern sign manufacturer, the sign itself will be slightly larger to accommodate the display components. This size difference is necessitated by the technological updates, not by choice.

6. Title And Plan Purposes: The variation would not result in a use or development of the subject lot that would be not in harmony with the general and specific purposes for which this title and the provision from which a variation is sought were enacted or the general purpose and intent of the comprehensive plan.

The replacement sign will maintain the original display's location and appearance, ensuring harmony with the lot as it appeared before the unit display issues. This sign update will continue to inform the community about new developments within Siete 7 and the Des Plaines Area. Furthermore, the sign will remain non-distracting and consistent with the style of other signage along I-90.

7. No Other Remedy: There is no means other than the requested variation by which the alleged hardship or difficulty can be avoided or remedied to a degree sufficient to permit a reasonable use of the subject lot.

The requested variance is essential because no other suitable alternative exists, such as a smaller size, different design, or different product. The chosen sign unit is the optimal solution for its current location. Specifically, this unit is ideal for being out in the open and enduring the elements, making it the best option to withstand snowy and rainy weather conditions in the Midwest.

8. Minimum Required: The requested variation is the minimum measure of relief necessary to alleviate the alleged hardship or difficulty presented by the strict application of this title.

-The requested variation is the minimum measure of relief necessary to alleviate the difficulty presented by the strict title. We are requesting a minimum relief of just 19.89 square feet per side in order to accommodate for the replacement of a non-functioning sign.



April 15, 2026

Mayor Goczkowski and Des Plaines City Council  
CITY OF DES PLAINES

**Subject:** Planning and Zoning Board – 999 E. Touhy Avenue, Case #26-008-CU-V

**RE:** Consideration of a Conditional Use and Major Variation for an Electronic Message Board Sign

Honorable Mayor and Members of the Des Plaines City Council:

The Planning and Zoning Board (PZB) held a public hearing on April 14, 2026 to consider the request.

1. Sam and Carmela Menna from Omega signs presented the conditional use and major variation requests for the proposed Electronic Message Board (EMB) sign showing an aerial image of the property all existing signs identified and the location of the existing EMB sign to be replaced. They noted that the new sign will utilize the same structure/location as the existing sign but will be 9 square feet larger on each side. She added that the sign will not have any sounds, not be distracting, and will be compliant with all city requirements. Ms. Menna also explained that landscape plantings will be added at the base of the EMB sign. Dante Moneverde, representing the petitioner/property owner, added that the existing EMB sign is a great amenity to the tenants on site but is also a great asset for the community because this sign does display community messages as well.
2. PZB members asked if the proposed sign is the same design but is larger because it does not have a border; what advertising will be on the sign; how people traveling on the highway know where their development is located without address on sign; is the new sign the same dimensions as the current sign just without the border; is it possible to customize the size of the digital signs or are they are standardized; is the sign still visible from the highway; if staff has spoken to the petitioner about the proposed conditions of approval; and if they are aware of these conditions.

Ms. Menna responded the new sign will be the same design as the current sign just without the border; that they can add the property address into the program to display with each advertisement copy; that the proposed sign dimensions are the same as the current sign given the previous approval did not factor in the sign border; that the digital signs are made up of pre-manufactured three-foot-tall by three-foot-wide panels that are stacked on one another so they cannot customize the digital sign sizes but can customize non-digital signs; and that the sign will still be visible from the highway. Mr. Monteverde confirmed that the sign will advertise businesses operating on site as well as city messages and that the current sign is located between the building on site and highway but does not have the property address anywhere on it.

City staff confirmed that the staff report with the recommended conditions were provided to the petitioner on the Friday prior to the PZB meeting and while a formal discussion did not occur regarding these conditions, the petitioner is aware of the recommended conditions of approval for these requests.

3. CED staff summarized the staff report with slides providing an analysis of the requests and the proposed sign improvements. Staff acknowledged the two recommended conditions of approval and the motion before the PZB.

4. A member of the public acknowledged that she originally had concerns when she received the notice of this request but is no longer concerned after hearing the proposal and feels the request makes sense.
5. The PZB voted 5-0 to recommend that City Council approve the conditional use and major variation requests with the two staff recommended conditions as written.

Respectfully submitted,



Joseph Catalano,  
Des Plaines Planning and Zoning Board, Vice Chairman  
Cc: City Officials/Aldermen

**April 6, 2026 City Council meeting results:**

- Approved Text Amendments to the City Code, Title 12, Zoning Regarding Regulations for Off-Street Parking, Accessory Uses Related to EV Readiness and Drive-Through Facility Operation and Layout Design Regulations – 1st Reading (from the March 10, 2026 PZB recommendation)
- Approved a Final Plat of Subdivision from Section 13-2-8 of the Subdivision Regulations to Split One Lot into Two Lots at 1055 S. Mt. Prospect Road and 30 E. Algonquin Road (from the March 10, 2026 PZB recommendation)
- Approved a Final Plat of Subdivision from Section 13-2-8 of the Subdivision Regulations to Consolidate Two Lots into One Lot at 25 & 95 E. Algonquin Road (from the March 10, 2026 PZB recommendation)

**Reminder of March 20, 2026 Clerk’s Office email:**

Please forward a copy of your Cook County Statement of Economic Interests and the Disclosure Statement to the City Clerk’s office by May 1, 2026.

**Discuss staff memo formatting**

**ADMINISTRATIVE DECISIONS:**

None

**PENDING APPLICATIONS:**

1. **Address:** 999 E. Touhy Avenue **Case Number:** 26-008-CU-V

The petitioner requests: (i) a conditional use amendment to allow an electronic message board (EMB) sign in the C-2 Limited Office Commercial district at 999 E. Touhy Avenue; (ii) a major variation to allow an EMB sign that exceeds 500 square feet in area per side; and (iii) and any other variations, waivers, and zoning relief as may be necessary.

**Petitioner/Owner:** ALM 7 LLC and DPM LLC (Representative:, 999 E. Touhy Avenue, Suite 120, Des Plaines, IL 60018)

Acting Chairman Catalano swore-in the petitioner representatives – Dante Monteverde (property owner representative), Sam Menna and Carmella Menna (sign contractors).

Ms. Menna presented the conditional use and major variation requests for the proposed Electronic Message Board (EMB) sign in detail consistent with the agenda packet plans. She showed an aerial image of the property all existing signs identified and the location of the existing EMB sign to be replaced. She noted that the new sign will utilize the same structure/location as the existing sign but will be 9 square feet larger on each side. She added that the sign will not have any sounds, not be distracting, and will be compliant with all city requirements. Ms. Menna also explained that landscape plantings will be added at the base of the EMB sign.

Dante Moneverde, representing the petitioner/property owner, added that the existing EMB sign is a great amenity to the tenants on site but is also a great asset for the community because this sign does display community messages as well.

Acting Chair Catalano asked if the proposed larger area is more sign communication area versus the existing. Mr. Menna stated the new sign incorporates area for sign communications that is current sign structure on the existing sign and this accounts for the additional 9 sq. ft. of sign area variation request.

Member Weaver asked about the intended messages using the sign. Mr. Monteverde stated the proposed sign will only be for 999 E. Touhy Avenue tenants within prescribed parameters.

Member Weaver asked how drivers on I-90 will know how to access the subject property as they pass by the sign. Mr. Monteverde stated the sign does not have an address on the proposed sign consistent with the current sign's longstanding existing conditions. Mr. Menna added that the property address could be added on the sign display for each advertisement.

Member Weaver asked about the dimensions of the proposed sign versus the frame of the existing sign to confirm if the visible sign area is the same. Mr. Menna confirmed that the visible area of the sign is staying the same and that the previous approval did not include the sign cladding.

Member Weaver asked why the sign is the same size and if they were utilizing the same pole and structures above the pole. Mr. Menna stated the same pole will be utilized but the sign frame and internal EMB equipment will be replaced as part of the proposed sign's rehabilitation. EMB components are being replaced within the existing sign's structure.

Member Weaver and the sign contractor discussed sign customization and why the proposed sign must use existing sign structure. Mr. Menna stated that EMB displays are modular, prefabricated, and fit together like Legos. The EMB modules have specific component dimensions that are not able to be customized, so a small EMB sign would be substantially smaller than the existing/proposed because the new sign would have fewer individual EMB modules. Ms. Menna stated that a smaller sign reduces legibility from I-90. Mr. Monteverde stated the I-90 wall was raised in the intervening years.

Member Weaver asked if they were proposing to extend the height of the sign. Mr. Monteverde responded no.

Member Fowler asked if the sign would still be fully visible. Mr. Monteverde responded yes, just as it is currently.

Acting Chairman Catalano asked for public comment.

Public Comment – Jane Brill lives north of subject property and does not have concerns with proposal.

Acting Chairman Catalano asked for staff analysis.

Senior Planner Jonathan Stytz presented the staff analysis.

**Issue:** The petitioner requests a conditional use and a major variation to allow an EMB sign on the subject property in the C-2 Limited Office Commercial district at 999 E. Touhy Avenue that exceeds the maximum sign area permitted for a EMB sign for a qualified property.

**Petitioners/Owners:** ALM 7 LLC and DPM LLC (Representative: Dante Monteverde, 999 E. Touhy Avenue, Suite 120, Des Plaines, IL 60018)

**Case Number:** #26-008-CU-V

**PIN:** 09-32-101-030-0000

**Ward Number:** #5, Alderman Thomas Merlin

**Existing Zoning:** C-2, Limited Office Commercial district

**Existing Land Use:** Multi-Tenant Office Building with Off-Street Parking Area

**Surrounding Zoning:** North: R-1, Single Family Residential District (City of Des Plaines)  
South: PD-0, Planned Development District (City of Chicago)  
East: C-2, Limited Office Commercial district (City of Des Plaines)  
West: C-3, General Commercial District (City of Des Plaines)

**Surrounding Land Uses:** North: Single Family Residences (residential) / Park (recreational)  
South: Industrial Warehouses (industrial)  
East: Multi-Tenant Office Building (commercial)  
West: Convenience Mart Fueling Station (commercial)

**Street Classification:** Touhy Avenue is classified as an *other principal arterial* road under Illinois Department of Transportation (IDOT) jurisdiction.

**Comprehensive Plan:** The Comprehensive Plan designates this site as *Commercial*.

**Property/Zoning History:** The subject property was annexed into the City in 1966 as an office building with an off-street parking lot<sup>1</sup>. Based on City records, a conditional use was approved June 20, 2011 through Ordinance Z-18-11 (attached) to allow a 45-foot-tall, 500-square-foot EMB sign to be installed on the subject property, which is classified as a qualified EMB property pursuant to Section 12-11-5.G.7 of the Zoning Ordinance. There are existing items to address related to parking lot improvements and fire inspections, which both must be addressed to comply with all current regulations.

<sup>1</sup> <https://www.historicaerials.com/location/41.625/-87.875/T1890/16>. Retrieved April 7, 2026.

## CONDITIONAL USE

### **Request Summary:**

#### *Overview*

The petitioner requests replacing an existing Electronic Message Board (EMB) sign, as defined below, on the subject property to advertise for the specific uses within the multi-tenant office building and various City of Des Plaines messages pursuant to the current community messaging agreement.

**SIGN, ELECTRONIC MESSAGE BOARD:** A sign whose informational content can be changed or altered by manual or electric, electromechanical or electronic means (Section 12-13-3 of the Zoning Ordinance).

Pursuant to Section 12-11-5.G of the Zoning Ordinance, an EMB sign is a separate sign type that is only allowed in certain zoning districts and under specific regulations.

#### *Qualified EMB Property Exception*

Pursuant to Section 12-11-5.G.7 of the Zoning Ordinance, properties that meet the below criteria are classified as a qualified EMB property and are allowed additional EMB sign allowances than regular EMB signs:

- Occupies a parcel of land of not less than 15 acres zoned C-2 or C-3 or contiguous parcels of land of not less than 15 acres zoned C-2 or C-3 with either vehicular cross access easements or shared parking agreements that are recorded with the Cook County Recorder of Deeds;
- Is improved with multi-story, multi-tenanted office building(s) that have more than 400,000 square feet of rentable space; and
- Has a combined frontage of at least 200 linear feet on I-90 or I-294.

In 2011, Ordinance Z-18-11 approved a conditional use for a 45-foot-tall, 500-square-foot EMB sign on the basis that the subject property met all requirements to be classified as a qualified EMB property. Staff confirms the above Qualified EMB property criteria are still met today.

#### *EMB Sign Regulations for Qualified EMB Properties*

An EMB sign on a qualified EMB property has slightly different standards in Section 12-11-6.B than an EMB sign on a typical, non-qualified EMB property but is still regulated by location, quantity, size, and operation to minimize any adverse effects on surrounding developments.

- Location: Qualified EMB properties must be located in either the C-2 or C-3 zoning districts and a conditional use is required to allow the installation of an EMB sign under the qualified EMB property exception in Section 12-11-5.G.7 of the Zoning Ordinance. Any EMB sign associated with a qualified EMB property shall be: (i) located between I-90 or I-294 and the structure(s) on the subject qualified EMB property, and (ii) screened from any residential property.
- Quantity: Only one EMB sign is permitted per qualified EMB property even in the case of business parks, retail centers, and multi-lot uses<sup>2</sup>.
- Size: An EMB sign on qualified EMB properties cannot exceed 500 square feet in area<sup>3</sup>.
- Operation: The changeable copy on the EMB sign must be specific to the businesses or organizations residing on the qualified EMB property and is only for tenants with a lease of 3 years, actually occupies and operates a space of at least 500 square feet within the building. The EMB sign cannot make any sounds and must be equipped with light dimming device or timer to reduce light intensity based on time of day. The changeable copy on the EMB sign cannot be changed more than one every 7.5 seconds or as established by Federal or State Guidelines, whichever is greater.

#### *EMB Sign Proposal*

The petitioner proposes replacing the existing two-sided EMB sign with a new larger, two-sided sign in the same location as the current sign as illustrated on the attached Sign Plans. The current sign is surrounded by a wood fence and its base is void of landscaping improvements. However, as part of this request, the petitioner has provided a landscape diagram illustrating the proposed plantings around the sign base outside of the existing fence enclosing the sign base.

The table analyzes how the proposed EMB sign aligns with Section 12-11-6.B of the Zoning Ordinance for EMBs for qualified EMB properties. The EMB sign will exceed 500 square feet in area, requiring a major variation.

---

<sup>2</sup> Excluding EMB signs embedded within electric vehicle (EV) charging ports and drive-through menu board signs.

<sup>3</sup> Excluding EMB signs embedded within EV charging ports and drive-through menu board signs, which have specific regulations.

| EMB Sign for Qualified EMB Property |  |  |                                   |
|-------------------------------------|--|--|-----------------------------------|
| Standard                            | Requirement  | Existing   | Proposed                          |
| Sign Height                         | 45 FT Maximum  | 45 FT  | 45 FT                             |
| Total Sign Area                     | 500 SF Maximum   | 488 SF   | <b>509 SF*</b>                    |
| Sign Quantity                       | Up to One Sign Permitted   | One  | One                               |
| Sign Location                       | Must be located between I-90 or I-294 & structure(s) on site and be screened from all residences | Located between office building & I-90 and is screened from residences | <i>No change to sign location</i> |

*\*A major variation is required for the EMB sign area.*

**Major Variation**

**Request Summary:**

*Overview*

As noted above, the proposed EMB monument sign will be 509 square feet in area, which exceeds the maximum 500-square-foot sign area permitted in Section 12-11-6.B for EMBs on qualified EMB properties. While the sign is screened from residential, the PZB should consider the adverse effects of this sign type on motorists and whether the increase size is feasible in this location.

*Consideration of Alternatives*

There are alternatives available that do not require the conditional use and variation application requested:

- Like for Like Replacement of Current Sign: Allows replacement of the current sign size and structure with little to no adjustments.
- Slight Enlargement of Current Sign to Max Area Allowed: Allows an enlargement of the sign to the maximum 500 SF permitted—which is included in the original 2011 approval—for a larger display but primarily same function as the existing sign.

*Other Considerations*

In its review of this request, the PZB may also consider the following:

- 2019 Comprehensive Plan: This plan provides general goals and strategies for the implementation of gateway and wayfinding signs throughout the City, especially in the downtown area and specific significant street corridors, to promote uniform identity and reduce visual clutter through sign regulation. *It does not, however, promote or seek to*

*increase the installation and use of EMBs or other signs that could visually clutter along corridors for private property. As a result, the proposal would not align with a specific goal or strategy of the City's 2019 Comprehensive Plan.*

- City's Zoning Ordinance: Chapter 11 of the Zoning Ordinance provides comprehensive regulations of signs in the City to:
  - Provide *reasonable yet appropriate conditions* for identifying businesses and services rendered in commercial, institutional and industrial areas;
  - *Reduce traffic hazards by restricting signs and lights which exceed a viewer's capacity to receive information, or which increases the potential for accidents created by signage which distracts or obstructs a viewer's vision;* and
  - *Protecting the health, safety and general welfare* of the residents of the City.

**Conditional Use Findings:** Conditional Use requests are subject to the standards set forth in Section 12-3- 4(E) of the Zoning Ordinance. Rationale for how the proposed amendments would satisfy the standards is provided below and in the attached Petitioner's Responses to Standards. As its rationale for its determination, the Board may use the responses provided as written, modify, or adopt its own.

**1. The proposed Conditional Use is in fact a Conditional Use established within the specific Zoning district involved:**

Comment: An EMB for a qualified EMB property is a special sign only permitted through a conditional use as specified in Section 12-11-5.G.7 of the Zoning Ordinance for properties in the C-2 Limited Office Commercial District.

**2. The proposed Conditional Use is in accordance with the objectives of the City's Comprehensive Plan:**

Comment: The Comprehensive Plan designates this property as commercial and strives to foster growth and retention of existing commercial businesses in Des Plaines. However, the proposed private EMB sign may not align with the general goals and strategies for commercial properties in the city.

**3. The proposed Conditional Use is designed, constructed, operated and maintained to be harmonious and appropriate in appearance with the existing or intended character of the general vicinity:**

Comment: In addition to the existing EMB sign on the subject property, there are other EMB signs in the immediate area alongside the I-90 corridor so it can be argued that the proposed EMB sign could be harmonious and appropriate with the existing character of general vicinity of this commercial corridor.

**4. The proposed Conditional Use is not hazardous or disturbing to existing neighboring uses:**

*Comment:* EMBs by their nature are designed to attract attention with lights and movement and, therefore, could be considered inherently disturbing to neighboring uses. Moreover, the light and imagery emitted from these signs could be distracting to motorists potentially creating hazardous conditions. In the case of the subject property, the proposed two-sided EMB sign will face westbound and eastbound I-90 travel lanes and could result in hazardous or disturbing conditions to motorists. While existing EMB signs exist along this corridor, the PZB should decide if the proposed larger EMB sign is appropriate for the subject property or if a 500-square-foot or less sign would suffice instead.

**5. The proposed Conditional Use is to be served adequately by essential public facilities and services, such as highways, streets, police and fire protection, drainage structures, refuse disposal, water and sewer, and schools; or, agencies responsible for establishing the Conditional Use shall provide adequately any such services:**

*Comment:* The subject property is currently served adequately by essential public facilities and services. Given the proposed EMB will be served by the existing electrical service feeding the current building, there are no concerns from staff to the adequacy of existing public facilities and services or the need for additional public facilities and services with the proposed EMB on the subject property.

**6. The proposed Conditional Use does not create excessive additional requirements at public expense for public facilities and services and will not be detrimental to the economic well-being of the entire community:**

*Comment:* While there is no indication the proposed EMB will create excessive additional requirements for public facilities and services, PZB should consider whether the larger EMB sign is feasible or necessary to appropriately advertise the individual uses on the subject property.

**7. The proposed Conditional Use does not involve uses, activities, processes, materials, equipment and conditions of operation that will be detrimental to any persons, property, or the general welfare by reason of excessive production of traffic, noise, smoke fumes, glare or odors:**

*Comment:* The EMB itself does not produce any traffic, smoke fumes, or odors by design. However, glare is a common adverse effect from digital signs that could impact neighboring properties and motorists.

Related to glare, Section 12-11-5.G prohibits the use of flashing and animated signs as defined above to partially address the glare concern. However, the light emittance from the sign can still cause glare either from natural or ambient light sources, which could impact motorists and neighboring properties alike, especially during evening hours.

**8. The proposed Conditional Use provides vehicular access to the property designed so that it does not create an interference with traffic on surrounding public thoroughfares:**

*Comment:* The subject property contains a single access point from Touhy Avenue that will not change or be impacted by the installation of the proposed EMB monument sign.

**9. The proposed Conditional Use does not result in the destruction, loss, or damage of natural, scenic, or historic features of major importance:**

*Comment:* The proposal would not cause the destruction, loss, or damage of any natural, scenic or historic features as the site is already developed. Furthermore, the proposal does include the installation of landscaping around the sign base that will help soften the EMB monument sign base.

**10. The proposed Conditional Use complies with all additional regulations in the Zoning Ordinance specific to the Conditional Use requested:**

*Comment:* Aside from the major variation for EMB sign area, this proposal is anticipated to meet all other requirements of the Zoning Ordinance for the C-2 Limited Office Commercial District. Moreover, EMBs are governed under standards in Sections 12-11-5.G and 12-11-6.B, which the petitioner is required to comply with for the life of the conditional use and operation of the EMB sign.

**Standards for Variation:** The following is a discussion of standards for variations from Section 12-3-6(H) of the Zoning Ordinance. Rationale for how the proposed use would satisfy the standards as provided below and in the petitioner's response to standards. The PZB may use this rationale toward its recommendation, or the Board may make up its own.

**1. Hardship: No variation shall be granted pursuant to this subsection H unless the applicant shall establish that carrying out the strict letter of the provisions of this title would create a particular hardship or a practical difficulty.**

*Comment:* Staff does not believe a hardship or practical difficulty exists preventing the petitioner from complying with the sign area requirement. A 500-square-foot or less EMB sign has already been permitted through Ordinance Z-18-11 and the replacement of this sign within this existing approval does not require a conditional use or variation request. The petitioner's pursuit of a larger digital sign with the inability to comply with the additional standards required for such sign type is ill-advised and could be defined as a perceived inconvenience as opposed to a hardship or practical difficulty. As the request may not constitute a defined hardship or practical difficulty, approving the variation for a larger EMB sign, especially when ample options to comply with current regulations are easily accessible, could defeat the intention of the sign area requirement for EMBs and create unnecessary adverse effects to motorists and nearby uses.

**2. Unique Physical Condition: The subject lot is exceptional as compared to other lots subject to the same provision by reason of a unique physical condition, including presence of an existing use, structure, or sign, whether conforming or nonconforming; irregular or substandard shape or size; exceptional topographical features; or other extraordinary physical conditions peculiar to and inherent in the subject lot that amount to more than a mere inconvenience to the owner and that relate to or arise out of the lot rather than the personal situation of the current owner of the lot.**

*Comment:* The subject property attributes are not uncommon for properties along the I-90 or I-294 tollways throughout the City, many of which with similar lot dimensions, shapes, and areas. As such, the lot size and shape are not considered an exceptional or unique attribute of the subject property. In addition, there are no exceptional topographical or extraordinary features on the subject property that would have impact on the EMB sign size. Thus, the variation request could be considered a personal preference and convenience of the property owner instead of a unique physical condition of the subject property.

- 3. Not Self-Created: The aforesaid unique physical condition is not the result of any action or inaction of the owner or its predecessors in title and existed at the time of the enactment of the provisions from which a variance is sought or was created by natural forces or was the result of governmental action, other than the adoption of this title.**

*Comment:* While the property attributes are not necessarily the result of a known action by the current owner or their predecessors, the proposed EMB sign size is a direct result of the current property owner despite knowledge of Ordinance Z-18-11 limiting the sign area to 500 square feet in area. As such, it could be concluded that the variation request is not the inability of the petitioner to meet the EMB sign requirements due to a defined unique physical attribute of the subject property, but rather by the petitioner's desire for a larger EMB sign area that exceeds the maximum sign area allowed even though alternative sign designs and sizes exist, many of which would meet the EMB sign requirements.

- 4. Denied Substantial Rights: The carrying out of the strict letter of the provision from which a variance is sought would deprive the owner of the subject lot of substantial rights commonly enjoyed by owners of other lots subject to the same provision.**

*Comment:* Staff believe carrying out the strict letter of this code for EMBs may not deprive the property owner of substantial rights. First, having the ability to install an EMB sign is not, in and of itself, a permitted right granted to property owners. In fact, the Zoning Ordinance specifically limits the size and location of EMB signs to limit their use to properties able to meet the additional requirements and minimize adverse effects on neighboring properties. This is why only a select few zoning districts permit EMBs by right whereas many zoning districts either prohibit EMBs altogether or require additional approvals, as in the case of the subject C-2-zoned property. Furthermore, even less properties meet the standards in Section 12-11-5.G.7 to be classified as a qualified EMB property and be allowed to install a substantially larger EMB sign than what is permitted anyone else in the City.

Enforcing these regulations, especially for an EMB sign, does not deny property owners the opportunity to install and utilize an EMB sign on the subject property but requires said sign to conform with all requirements. Therefore, enforcing the applicable requirements for EMB sign would not prevent the property owner from replacing the existing EMB sign, but rather restrict its area to not exceed 500 square feet, which is clearly stated in the approval of the original EMB sign in 2011.

- 5. Not Merely Special Privilege: The alleged hardship or difficulty is neither merely the inability of the owner or occupant to enjoy some special privilege or additional right not available to owners or occupants of other lots subject to the same provision, nor merely the inability of the owner to make more money from the use of the subject lot.**

*Comment:* Granting this variation for a larger EMB sign that exceeds 500 square feet—which is already substantially larger than many other properties are eligible to install—could provide a special privilege for the property owner not available to other property owners in the city regardless of the design and orientation of the sign. The subject property was approved for a maximum 500-square-foot EMB sign and a 488-square-foot EMB sign was requested and approved as noted in the attached Ordinance Z-18-11 and Original Sign Permit.

While technological advancements in EMB sign may be available today, Ordinance Z-18-11 was approved by the City and acknowledged by the property owner with the understanding the EMB sign would not exceed 500 square feet in area. As such, a request for the larger EMB sign with full knowledge of the maximum sign area allowed trends on providing a special privilege for this current user. Given that there are arguably better and more appropriate sign alternatives available for the subject property than the requested variation, the PZB and City Council should consider whether a sign area variation of this amount for an EMB sign would be appropriate on the subject property.

- 6. Title And Plan Purposes: The variation would not result in a use or development of the subject lot that would be not in harmony with the general and specific purposes for which this title and the provision from which a variation is sought were enacted or the general purpose and intent of the comprehensive plan.**

*Comment:* The installation of an EMB sign may not align with the general and specific purposes of the Zoning Ordinance nor the purpose and intent of the Comprehensive Plan. The 2019 Comprehensive Plan does not mention EMB signs in any capacity and the Zoning Ordinance establishes specific regulations for any EMB signs. Section 12-7-3.D of the Zoning Ordinance defines the purpose of the C-1 district “to preserve existing office development and provide locations for the development of new office locations.” While signs are inherently helpful to advertise various commercial properties, an EMB sign, especially at the size requested, is not necessarily appropriate in this case.

- 7. No Other Remedy: There is no means other than the requested variation by which the alleged hardship or difficulty can be avoided or remedied to a degree sufficient to permit a reasonable use of the subject lot.**

*Comment:* The *Consideration of Alternatives* section above and Section 12-11-6.B of the Zoning Ordinance identify viable alternatives to the proposed conditional use and variation being requested by the petitioner. While staff have discussed these options with the petitioner, out of convenience the petitioner has requested approval of the proposed larger EMB sign. Given the multiple alternatives available to the petitioner, the PZB may wish to ask why certain alternative designs are not feasible.

- 8. Minimum Required: The requested variation is the minimum measure of relief necessary to alleviate the alleged hardship or difficulty presented by the strict application of this title.**

*Comment:* The variation request may not be the minimum measure of relief to address the petitioner’s concerns. Instead, the installation of a like-for-like replacement or slightly larger sign not exceeding 500 square feet would adequately advertise the subject property and meet

the applicable city ordinances all while minimizing adverse effects on surrounding properties.

**PZB Procedure and Recommended Conditions:** Under Sections 12-3-4 (Procedure for Review and Decision of Conditional Uses) and 12-3-6.G.2.b (Procedure for Review and Decision of Major Variations) of the Zoning Ordinance, the PZB has the authority to *recommend* that the City Council approve or deny the requests for a conditional use and major variation.

Consideration of the requests should be based on a review of the information presented by the applicant and the findings made above, as specified in Sections 12-3-4 (Standards for Conditional Uses) and 12-3-6.H (Standards for Variation) of the Zoning Ordinance. If the PZB recommends and City Council ultimately approves the request, staff recommends the following conditions.

**Conditions of Approval:**

1. A minimum three-foot-wide landscape bed is required to be installed and maintained around the entire sign base. The landscape bed shall be improved with evergreen bushes not less than three feet in height in front of the sign and shorter shrubs and perennials along the fence enclosure around the sign base.
2. At time of the building permit process, the Electronic Message Board (EMB) sign plans may be modified as necessary to comply with all local and state requirements, provided the total sign area is not increased in size.

Member Weaver asked if petitioner received the proposed conditions of approval from staff. Senior Planner Stytz stated they received the staff report and had no known concerns.

Member Weaver moved and Member Veremis seconded a motion to recommend the City Council approve the proposed Conditional Use and Major Variation request with the staff suggested conditions of approval.

AYES: Weaver, Veremis, Fowler, Zadrozny and Catalano

NAYS: None

ABSTAIN: None

\*\*\*MOTION CARRIED\*\*\*

**CITY OF DES PLAINES**

**ORDINANCE Z – 8 – 26**

**AN ORDINANCE APPROVING A CONDITIONAL USE PERMIT AND MAJOR VARIATION FROM SECTION 12-11-6.B OF THE ZONING ORDINANCE TO ALLOW AN ELECTRONIC MESSAGE BOARD AT 999 E. TOUHY AVENUE, DES PLAINES, ILLINOIS (Case #26-008-CU-V).**

---

**WHEREAS**, ALM 7 LCC and DPM LLC are the owners (collectively, the *“Petitioner”*) of the property commonly known as 999 E. Touhy Avenue (*“Subject Property”*), which is located in the City; and

**WHEREAS**, the Subject Property is located in the C-2 Limited Office Commercial District (*“C-2 District”*) and is improved with a multi-tenant office building with an off-street parking area; and

**WHEREAS**, the Petitioner proposes to replace an existing electronic message board (*“EMB”*) with a new, larger two-sided EMB monument sign on the Subject Property (*“Proposed EMB”*); and

**WHEREAS**, the City of Des Plaines Zoning Ordinance of 1998, as amended, is codified as Title 12 of the City Code of the City of Des Plaines (*“Zoning Ordinance”*); and

**WHEREAS**, the Subject Property is classified as a "qualified EMB property" pursuant to Section 12-11-5.G.7 of the Zoning Ordinance; and

**WHEREAS**, pursuant to Section 12-11-5.G.7 of the Zoning Ordinance, an EMB is only permitted in the C-2 District with a conditional use permit (*“Conditional Use”*); and

**WHEREAS**, pursuant to Section 12-11-6.B of the Zoning Ordinance, an EMB on a qualified EMB property cannot exceed 500 square feet in area; and

**WHEREAS**, Petitioner desires to install the Proposed EMB on the Property with a total sign area of 509 square feet, which exceeds the maximum permitted area; and

**WHEREAS**, pursuant to Sections 12-3-4 and 12-3-6 of the Zoning Ordinance, the Petitioner has filed an application with the City for the approval of: (i) a conditional use permit to allow an EMB on the Subject Property in the C-2 District (*“Requested Conditional Use Permit”*); and (ii) a major variation from Section 12-11-6.B to increase the maximum permitted sign area from 500 square feet to 509 square feet (*“Requested Major Variation”*) (collectively, the Requested Conditional Use Permit and Requested Major Variation are the *“Requested Relief”*); and

**WHEREAS**, the Petitioner’s application for the Requested Relief was referred by the Department of Community and Economic Development to the Planning and Zoning Board (“**PZB**”) within 15 days after receipt of the application; and

**WHEREAS**, within 90 days after the date of the Petitioner's application, a public hearing was held by the PZB on April 14, 2026, pursuant to publication in the *Des Plaines Journal* on March 25, 2026; and

**WHEREAS**, notice of the public hearing was mailed to all property owners within 500 feet of the Subject Property; and

**WHEREAS**, during the public hearing, the PZB heard testimony and received evidence with respect to how the Petitioner intended to satisfy and comply with the provisions of the Zoning Ordinance; and

**WHEREAS**, on April 14, 2026, the PZB recommended that the City Council approve, by a vote of 5-0, the Requested Relief, subject to certain conditions; and

**WHEREAS**, pursuant to Sections 12-3-4 and 12-3-6 of the Zoning Ordinance, the PZB filed a written report with the City Council on April 15, 2025, summarizing the testimony and evidence received by the PZB and stating its recommendation; and

**WHEREAS**, the Petitioner made representations to the PZB with respect to the Requested Relief, which representations are hereby found by the City Council to be material and upon which the City Council relies in approving the Requested Relief; and

**WHEREAS**, the City Council has considered the written report of the PZB, the applicable standards for conditional uses and variations set forth in the Zoning Ordinance, and the Community and Economic Development Staff Memorandum dated April 23, 2026, and has determined that it is in the best interest of the City and the public to approve the Requested Relief in accordance with the provisions of this Ordinance;

**NOW, THEREFORE, BE IT ORDAINED** by the City Council of the City of Des Plaines, Cook County, Illinois, in the exercise of its home rule powers, as follows:

**SECTION 1. RECITALS.** The recitals set forth above are incorporated herein by reference and made a part hereof, the same constituting the factual basis for the approval of the Requested Relief.

**SECTION 2. LEGAL DESCRIPTION OF THE SUBJECT PROPERTY.** The Subject

Property is legally described as:

PARCEL 1:

LOT 1 IN O'HARE NORTH WEST OFFICE PARK SUBDIVISION, A SUBDIVISION OF PART OF THE NORTHWEST 1/4 OF SECTION 32, TOWNSHIP 41 NORTH, RANGE 12, EAST OF THE THIRD PRINCIPAL MERIDIAN, IN COOK COUNTY, ILLINOIS.

PARCEL 2:

EASEMENT FOR INGRESS AND EGRESS FOR THE BENEFIT OF PARCEL 1, AS CREATED BY AGREEMENT DATED DECEMBER 12, 1975 MADE BY AND BETWEEN LASALLE NATIONAL BANK, AS TRUSTEE UNDER TRUST NUMBER 48605 (GRANTOR), FIRST CHICAGO REALTY SERVICES CORPORATION (MORTGAGEE), AND LASALLE NATIONAL BANK, AS TRUSTEE UNDER TRUST NUMBER 46595 (GRANTEE), RECORDED DECEMBER 16, 1975 AS DOCUMENT 23325794, OVER AND ACROSS THE FOLLOWING:

THE NORTH 60.0 FEET, AS MEASURED AT RIGHT ANGLES AND CONCENTRIC WITH THE NORTHERLY LINE, OF THE FOLLOWING DESCRIBED TRACT OF LAND:

THAT PART OF THE NORTH 2/3 OF THE EAST 1/2 OF THE NORTHEAST 1/4 OF THE NORTHWEST 1/4 OF SECTION 32, TOWNSHIP 41 NORTH, RANGE 12, EAST OF THE THIRD PRINCIPAL MERIDIAN, LYING SOUTHERLY OF THE FOLLOWING DESCRIBED LINE:

BEGINNING AT A POINT ON THE WEST LINE OF THE EAST 1/2 OF THE NORTHEAST 1/4 OF THE NORTHWEST 1/4 OF SECTION 32 AFORESAID, A DISTANCE OF 634.43 FEET SOUTH OF THE NORTHWEST CORNER THEREOF, (SAID WEST LINE HAVING A BEARING OF SOUTH 00 DEGREE, 14 MINUTES, 58 SECONDS WEST FOR THE PURPOSES OF THIS DESCRIPTION); THENCE NORTH 88 DEGREES, 32 MINUTES, 18 SECONDS EAST, A DISTANCE OF 157.28 FEET TO A POINT ON A CURVE HAVING A RADIUS OF 376.94 FEET AND BEING CONCAVE TO THE NORTHWEST; THENCE NORTHEASTERLY ALONG SAID CURVE (THE CHORD OF SAID CURVE BEING NORTH 58 DEGREES, 48 MINUTES, 38 SECONDS EAST, A DISTANCE OF 390.77 FEET), AN ARC DISTANCE OF 398.65 FEET TO A POINT ON ANOTHER CURVE, WHICH HAS A RADIUS OF 490.0 FEET AND BEING CONCAVE TO THE SOUTHWEST, SAID POINT BEING 2.78 FEET SOUTHEASTERLY, (AS MEASURED ALONG THE ARC OF SAID CURVE FROM A POINT) WHICH LIES 644.0 FEET SOUTH, (AS MEASURED AT RIGHT

ANGLES) FROM THE NORTH LINE OF SAID NORTHWEST 1/4 OF SECTION 32 AND 175.0 FEET WEST, (AS MEASURED AT RIGHT ANGLES) FROM THE EAST LINE OF SAID NORTHWEST 1/4 OF SECTION 32 AND LYING WESTERLY OF THE FOLLOWING DESCRIBED LINE:

COMMENCING AT A POINT OF INTERSECTION OF THE SOUTH LINE OF THE NORTH 2/3 OF THE NORTHEAST 1/4 OF THE NORTHWEST 1/4 OF SECTION 32, WITH THE WESTERLY LINE OF THE RIGHT OF WAY OF THE ILLINOIS STATE TOLL HIGHWAY COMMISSION, WHICH WAS ACQUIRED BY CONDEMNATION FILED AS CASE NO. 573-1-501; THENCE NORTH 00 DEGREE, 17 MINUTES EAST ALONG SAID WESTERLY LINE OF THE RIGHT OF WAY OF THE ILLINOIS STATE TOLL HIGHWAY COMMISSION, A DISTANCE OF 145.7 FEET TO A POINT OF CURVATURE; THENCE NORTHWESTERLY ALONG A CURVED LINE CONCAVE TO THE SOUTHWEST, HAVING A RADIUS OF 490.0 FEET AND CENTRAL ANGLE OF 31 DEGREES, 30 MINUTES, A DISTANCE OF 312.42 FEET TO A POINT, DISTANCE 444.0 FEET SOUTH, MEASURED AT RIGHT ANGLES FROM THE NORTH LINE OF SAID NORTHWEST 1/4 OF SECTION 32 AND DISTANCE 175.0 FEET WEST, MEASURED AT RIGHT ANGLES FROM THE EAST LINE OF SAID NORTHWEST 1/4 OF SECTION 32; EXCEPTING THEREFROM THE FOLLOWING:

BEGINNING AT THE SOUTHWEST CORNER OF THE NORTH 2/3 OF THE EAST 1/2 OF THE NORTHEAST 1/4 OF THE NORTHWEST 1/4 OF SAID SECTION 32; THENCE EAST, A DISTANCE OF 156.30 FEET ALONG THE SOUTH LINE OF THE SAID NORTH 2/3; THENCE NORTHWESTERLY, A DISTANCE OF 68.02 FEET AT A LEFT DEFLECTION OF 145 DEGREES, 50 MINUTES, 15 SECONDS WITH THE LAST DESCRIBED COURSE TO A "POINT A"; THENCE NORTHWESTERLY, A DISTANCE OF 114.70 FEET ALONG AN ARC OF A CIRCULAR CURVE, CONCAVE TO THE LEFT WITH A RADIUS OF 3944.72 FEET, SAID CURVE BEING TANGENT TO THE LAST DESCRIBED COURSE AT SAID "POINT A" TO THE WEST LINE OF THE EAST 1/2 OF THE NORTHEAST 1/4 OF THE NORTHWEST 1/4 OF SAID SECTION 32; THENCE SOUTH, A DISTANCE OF 101.30 FEET ALONG SAID WEST LINE TO THE POINT OF BEGINNING OF EXCEPTION, ALL IN COOK COUNTY, ILLINOIS.

PARCEL 3:

EASEMENT FOR INGRESS AND EGRESS FOR THE BENEFIT OF PARCEL 1, AS CREATED BY RESERVATION IN WARRANTY DEED BY JACOB A. KELLEN AND HELEN E. KELLEN, HIS WIFE, AND JOHN P. KELLEN AND BARBARA M. KELLEN, HIS WIFE, TO CROW-GLAZE, INC., A PARTNERSHIP, DATED OCTOBER 5, 1968 AND RECORDED OCTOBER 22, 1968 AS DOCUMENT 20652556, OVER AND ACROSS THE WEST 30.00 FEET OF THE FOLLOWING DESCRIBED PROPERTY:

THE EASTERLY 342.0 FEET, (AS MEASURED ALONG TOUHY AVENUE) OF THAT PART OF THE WEST 1/2 OF THE NORTHEAST 1/4 OF THE NORTHWEST 1/4 OF SECTION 32, TOWNSHIP 41 NORTH, RANGE 12, EAST OF THE THIRD PRINCIPAL MERIDIAN, LYING NORTHERLY OF A LINE DESCRIBED AS FOLLOWS:

BEGINNING AT A POINT ON THE WEST LINE OF THE NORTHEAST 1/4 OF THE NORTHWEST 1/4 OF SAID SECTION 32, SAID POINT BEING 453.3 FEET SOUTH OF A CROSS IN THE PAVEMENT AT THE NORTHWEST CORNER OF THE NORTHEAST 1/4 OF THE NORTHWEST 1/4 OF SAID SECTION 32; THENCE SOUTHEASTERLY, A DISTANCE OF 19.3 FEET ALONG A STRAIGHT LINE MAKING AN ANGLE FROM NORTH TO SOUTHEAST OF 109 DEGREES, 50 MINUTES WITH THE WEST LINE OF THE NORTHEAST 1/4 OF THE NORTHWEST 1/4 OF SAID SECTION 32 TO A "POINT A;" THENCE SOUTHEASTERLY, A DISTANCE OF 704.6 FEET ALONG A CIRCULAR CURVE TO THE RIGHT, WITH A RADIUS OF 3944.72 FEET, SAID CURVE BEING TANGENT TO THE LAST DESCRIBED COURSE AT A "POINT A" TO THE EAST LINE OF THE WEST 1/2 OF THE NORTHEAST 1/4 OF THE NORTHWEST 1/4 OF SAID SECTION 32, SAID POINT BEING 543.5 FEET NORTH OF THE SOUTHEAST CORNER OF THE WEST 1/2 OF THE NORTHEAST 1/4 OF THE NORTHWEST 1/4 OF SECTION 32 AFORESAID, LYING SOUTHERLY OF A LINE DESCRIBED AS FOLLOWS:

BEGINNING AT A POINT ON THE WEST LINE OF THE NORTHWEST 1/4 OF THE NORTHWEST 1/4 OF SAID SECTION 32, DISTANT 50.0 FEET SOUTHERLY OF THE NORTH LINE OF SAID SECTION 32, AS MEASURED AT RIGHT ANGLES FROM SAID NORTH (LINE OF SECTION 32; THENCE SOUTHEASTERLY IN A STRAIGHT LINE, A DISTANCE OF 684.26 FEET TO A POINT IN THE EAST LINE OF THE WEST 1/2 OF THE NORTHEAST 1/4 OF THE NORTHWEST 1/4 OF SAID SECTION 32, DISTANT 70.0 FEET SOUTHERLY OF SAID NORTH LINE OF SECTION 32, AS MEASURED AT RIGHT ANGLES FROM SAID NORTH LINE OF SECTION 32, ALSO AS SHOWN ON O'HARE NORTHWEST OFFICE PARK SUBDIVISION AFORESAID, RECORDED AS DOCUMENT 23568729, AS TO THE WEST 30.00 FEET OF LOT 2 IN O'HARE NORTHWEST OFFICE PARK SUBDIVISION, AFORESAID, ALL IN COOK COUNTY, ILLINOIS.

**PARCEL 4:**

EASEMENT FOR INGRESS AND EGRESS FOR THE BENEFIT OF PARCEL 1, AS CREATED BY O'HARE NORTHWEST OFFICE PARK SUBDIVISION IN THE NORTHWEST 1/4 OF SECTION 32, TOWNSHIP 41 NORTH, RANGE 12, EAST OF THE THIRD PRINCIPAL MERIDIAN, AS SHOWN ON PLAT OF SUBDIVISION RECORDED JULY 22, 1976 AS DOCUMENT 23568729 OVER AND ACROSS A 30-FOOT STRIP OF LAND IN LOT 2 IN O'HARE NORTHWEST OFFICE PARK SUBDIVISION, AFORESAID, IN COOK COUNTY, ILLINOIS.

PARCEL 5:

EASEMENT FOR THE BENEFIT OF PARCEL 1 FOR PEDESTRIAN AND VEHICULAR TRAFFIC OVER, ACROSS, AND UPON ALL STREETS, ROADS, ALLEYS, AND WAYS NOW OR HEREAFTER LOCATED, AND FOR PARKING UPON ALL PUBLIC PARKING AREAS NOW OR HEREAFTER LOCATED ON THE PORTION OF TRACT A DESCRIBED ON EXHIBIT C ATTACHED THERETO, AS CREATED BY A RECIPROCAL EASEMENT AGREEMENT RECORDED MARCH 29, 1976 AS DOCUMENT 23432344, IN COOK COUNTY, ILLINOIS.

PIN: 09-32-101-030-0000

Commonly known as: 999 E. Touhy Avenue, Des Plaines, Illinois 60016

**SECTION 3. APPROVAL OF REQUESTED CONDITIONAL USE PERMIT.**

Subject to and contingent upon the conditions, restrictions, limitations and provisions set forth in Section 5 of this Ordinance, the Requested Conditional Use Permit to allow the installation and operation of the Proposed EMB on the Subject Property is hereby approved. The Requested Conditional Use Permit is consistent with and equivalent to a "special use" as referenced in Section 11-13-25 of the Illinois Municipal Code, 65 ILCS 5/11-13-25.

**SECTION 4. APPROVAL OF MAJOR VARIATION.** Subject to and contingent upon the conditions, restrictions, limitations and provisions set forth in Section 5 of this Ordinance, the Requested Major Variation for the Subject Property is hereby approved.

**SECTION 5. CONDITIONS OF APPROVAL.** The approvals granted in Sections 3 and 4 of this Ordinance are expressly subject to and contingent upon compliance by the Petitioner with each and all of the following conditions, all at the sole cost and expense of the Petitioner:

A. Compliance with Law and Regulations. The development, use, operation, and maintenance of the Proposed EMB and the Subject Property must comply with all applicable City codes and ordinances, as the same have been or may be amended from time to time, except to the extent specifically provided otherwise in this Ordinance.

B. Compliance with Plans. The development, use, and maintenance of the Proposed EMB and the Subject Property must be conducted in strict compliance with the following plans:

1. The Project Narrative, prepared by Omega Sign and Lighting INC, consisting of three pages, with a latest revision date of March 30, 2026, a copy of which is attached to and, by this reference, made a part of this Ordinance as *Exhibit A*; and

2. The Sign Plan, prepared by Omega Sign and Lighting INC, consisting of nine pages, with a latest revision date of March 11, 2026, a copy of which is attached to and, by this reference, made a part of this Ordinance as *Exhibit B*.

B. Additional Conditions. The development, use, and maintenance of the Subject Property, including the Proposed EMB, is subject to the following additional conditions:

1. A minimum three-foot-wide landscape bed is required to be installed and maintained around the entire sign base. The landscape bed shall be improved with evergreen bushes not less than three feet in height in front of the sign and shorter shrubs and perennials along the fence enclosure around the sign base.

2. At time of the building permit process, the Proposed EMB sign plans may be modified as necessary to comply with all local and state requirements, provided the total sign area is not increased in size beyond the requested 509 square feet.

3. The Proposed EMB must remain in compliance with all requirements for Electronic Message Board Billboards set forth in Section 12-11-6.B of the City Code, including requiring the Petitioners to enter into an agreement with the City regarding the display of City sponsored messages in a form acceptable to the City Manager and the City Attorney.

**SECTION 6. FAILURE TO COMPLY WITH CONDITIONS.**

A. Any person, firm, or corporation who violates, disobeys, omits, neglects, or refuses to comply with, or resists the enforcement of, any of the provisions of this Ordinance shall be fined not less than \$75.00 or more than \$750.00 for each offense. Each and every day that a violation of this Ordinance is allowed to remain in effect shall constitute a complete and separate offense. In addition, the appropriate authorities of the City may take such other action as they deem proper to enforce the terms and conditions of this Ordinance, including, without limitation, an action in equity to compel compliance with its terms. Any person, firm or corporation violating the terms of this Ordinance shall be subject, in addition to the foregoing penalties, to the payment of court costs and reasonable attorneys' fees.

B. In the event that the Petitioner fails to develop or maintain the Subject Property in accordance with the plans submitted, the requirements of the Zoning Ordinance, or the conditions set forth in Section 4 of this Ordinance, the approval granted by Section 3 of this Ordinance may be revoked after notice and hearing before the Zoning Administrator of the City, all in accordance with the procedures set forth in Section 12-4-7 of the Zoning Ordinance. In the event of revocation, the development and use of the Subject Property will be governed solely by the regulations of the C-2 District. Further, in the event of such revocation, the City Manager and the City's General Counsel are hereby authorized and directed to bring such zoning enforcement action as may be appropriate under the circumstances. The Petitioner acknowledges that public notices and hearings have been held with respect to the adoption of this Ordinance, has considered the possibility of the revocation provided for in this Section, and agrees not to challenge any such revocation on the grounds of any procedural infirmity or any denial of any procedural right, provided that the notice and hearing required by Section 12-4-7 of the Zoning Ordinance is

provided to the Petitioner.

**SECTION 7. SEVERABILITY.** If any paragraph, section, clause, or provision of this Ordinance is held invalid, the remainder shall continue in full force and effect without affecting the validity of the remaining portions of the Ordinance.

**SECTION 8. EFFECTIVE DATE.**

A. This Ordinance shall be in full force and effect subject to the occurrence of all the following:

1. its passage and publication in pamphlet form in the manner required by law;
2. the filing with the City Clerk by the Petitioner, not less than 60 days after the passage and approval of this Ordinance, of an unconditional agreement and consent to accept and abide by each and all of the terms, conditions, and limitations set forth in this Ordinance. Said unconditional agreement and consent shall be in substantially the form attached to, and by this reference made a part of, this Ordinance as *Exhibit C*;
3. at the Petitioner's sole cost and expense, the recordation of this Ordinance together with such exhibits as the City Clerk deems appropriate, with the Office of the Cook County Recorder.

B. In the event that the Petitioner does not file with the City Clerk a fully executed copy of the unconditional agreement and consent referenced in Section 8.A of this Ordinance, within 60 days after the date of passage of this Ordinance by the City Council, the City Council shall have the right, in its sole discretion, to declare this Ordinance null and void and of no force or effect.

[SIGNATURE PAGE FOLLOWS]

**PASSED** this \_\_\_\_\_ day of \_\_\_\_\_, 2026.

**APPROVED** this \_\_\_\_\_ day of \_\_\_\_\_, 2026.

**VOTE:** Ayes \_\_\_\_\_ Nays \_\_\_\_\_ Absent \_\_\_\_\_

\_\_\_\_\_  
**MAYOR**

ATTEST:

\_\_\_\_\_  
**CITY CLERK**

Published in pamphlet form this  
\_\_\_\_ day of \_\_\_\_\_, 2026.

Approved as to form:

\_\_\_\_\_  
**CITY CLERK**  
**Counsel**

\_\_\_\_\_  
**Peter M. Friedman, General**

DP Approval of Conditional Use and Major Variation for EMB at 999 E. Touhy Avenue

March 30th, 2026

Planning and Zoning Commission  
Community & Economic Development  
City of Des Plaines  
1420 Miner Street  
Des Plaines, IL 60016

Re: Siete 7 LLC, 999 E Touhy Ave. 60018, Des Plaines, IL

The proposal involves the replacement of one existing digital sign display labeled as P2 on the inset plan. The sign necessitates an increase in square footage for a 508.29 Sf Ft. sign. Consequently, this modification requires the granting of a variance and conditional use approval from the City of Des Plaines in accordance with the sign ordinance

Omega Sign & Lighting, representing Siete 7 LLC, has submitted this request to address the aid in a difficulty regarding the proposed additional square footage to the double-faced pole sign that was permitted previously under permit #12020118 in 2012 for a 488.40 Sf ft sign. The larger sign request is simply because each digital manufacturer has small size difference in cabinet size, additionally per our measurements the existing size of the unit on site was slightly larger than what was approved on the original permit. Furthermore, the business hours for Siete 7 LLC currently operate under Monday-Friday 6:00AM-6:00PM Saturday: 7AM-1PM, the sign replacement will not influence the company's hours or operations in any way. With respect to the sign display, the hours of operation will be determined by the Des Plaines sign ordinance. These points explain that the proposed sign replacement, require a need for variance and conditional use approval from the City of Des Plaines current Sign Ordinance. The following is a detailed response addressing all relevant points that will appease the sign Ordinance.

The request for a minor increase in square footage is due to slight differences in the manufacturing specifications for modern digital cabinets. Specifically, the new sign will require an increase in size—approximately 19.89 square feet per side—to ensure optimal functionality of the digital display. This constitutes the minimum measure of relief necessary to alleviate the difficulty presented by the strict ordinance. The change is minimal, as the sign will incorporate only a slight increase in square footage, which will preserve the current style and appearance of the existing sign and will not alter the character of the surrounding area. The location and height of the existing sign will remain unchanged, ensuring no physical alteration to its foundation or visual impact. Furthermore, the sign replacement will enhance the fixture's cohesion with the lot and maintain harmony with the subject lot as it originally appeared prior to the unit display issues.

Furthermore, the replacement will positively affect the area by mitigating a potential safety hazard and aesthetic detriment. The existing sign's malfunctioning illumination presents a safety concern for motorists who may be distracted by the unclear display. The replacement with a properly functioning unit will rectify current sign issues and will not be hazardous or disruptive to the neighboring area. The additional square footage is solely intended to repair and restore the digital components of the sign to operational status for the foreseeable future. Although the sign will be a bit larger by a few inches, it is unavoidable due to manufacturing differences. It is not anticipated that the properly functioning unit will negatively influence the surrounding area or negatively affect the economic welfare of the community.

All things considered, Omega Sign & Lighting formally requests that the City of Des Plaines approve the requested variance and conditional use for the proposed replacement of the digital display for Siete 7 LLC. We attest that this detailed submission comprehensively addresses all stated concerns and demonstrates that the sign will be a positive enhancement to the community. Additionally, Omega Sign & Lighting is committed to ensuring that all sign codes, conditions, and inspection requirements will be fully satisfied to maintain compliance with the city's regulations.

We welcome the opportunity to discuss this request further and provide any additional information that may be required.

Sincerely,

Leslie McCracken  
Permit Specialist



**P2**

**REMOVE EXISTING EMU & REPLACE WITH NEW EMU**

Option 1 - **Ledman 8MM**

REMOVE EXISTING EMU  
LEAVING POLE SUPPORTS /  
STRUCTURE INTACT  
REPLACE WITH NEW EMU

- Ledman 8MM
- Double Sided - V-Shape
- Matrix 756 x 792
- Cabinet / Viewing **22'-0.05" H x 23'-1.2" W**
- Novastar Controller
- Cloud Based Software
- Cellular & Data Plan - 10yr Opt-Connect

TOTAL SIGN HEIGHT IS 45'-0"

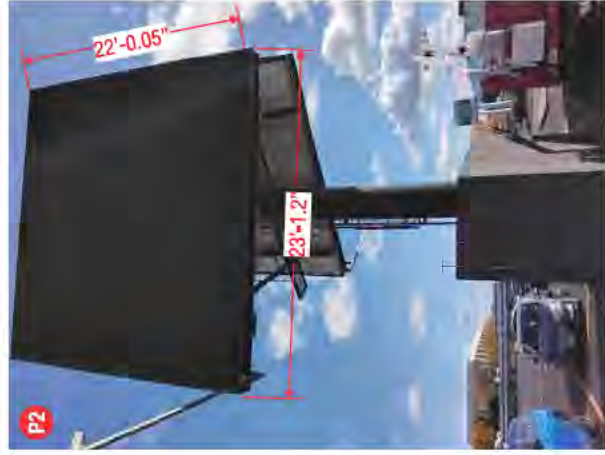

- The proposed Electronic Message Board signs shall conform to all Des Plaines Zoning Ordinance regulations regarding operational characteristics such as permitted and prohibited types of Electronic Message Boards, interval of message, brightness of signs, 2. Automatic Dimming. Electronic multiple message signs shall be equipped with light sensing devices or a scheduled dimming timer which automatically dims the intensity of the light emitted by the sign during ambient low-light and nighttime (dusk to dawn) conditions. The signs shall not exceed five hundred (500) nits of intensity as measured at the sign surface during nighttime and low-light conditions and five thousand (5,000) nits during daytime hours.
- The operator of the Electronic Message Board agrees to permit the City to post messages, including public service announcements, Amber Alerts and City information to be displayed no less than 3.5% of the total time the Electronic Message Board is operating in any 24 hour period. City messages will be displayed throughout such 24 hour period, with the majority of the display occurrences taking place during the periods from 5 a.m. to 11 a.m. and 1 p.m. to 9 p.m., unless the City requests a different over-night or middle of the night distribution. Notwithstanding the foregoing and without the consent of the City, the operator may cease displaying any announcements which may be outdated or superseded.



**Siete 7 LLC**  
999 E Touhy Ave.  
Des Plaines, IL 60018

|                 |                  |
|-----------------|------------------|
| Date            | 11/10/25         |
| Acct. Executive | Lauren Valdez    |
| Sheet #         | 001              |
| Revision Number | Date             |
| 1               | 00/00/00         |
| 2               | 12/18/25         |
| 3               | 01/12/26         |
| 4               | 02/06/26         |
| 5               | 2/11/2026        |
| 6               | REV.7 - 03/11/26 |
| Drawn By        | D. Townson       |

**For Design Intent Only\*\***  
**SQC # 251622-07**

PERMIT INFO

|   |  |
|---|--|
| Sign Sq. Ft.                            |  |
| No. of Lamps/LEDs                       |  |
| Total Wattage                           |  |
| No. of Power Supplies                   |  |
| Total Amperage                          |  |
| Ext. 20 Amp Toggle Switch w/Rubber Boot |  |

|                   |      |
|-------------------|------|
| Approval          | Date |
| Cust. Approval    | Date |
| Approval          | Date |
| Landlord Approval | Date |

**ELECTRICAL NOTES**  
Each Sign Must Have:  
1. A minimum of One (1) dedicated Sign company DOES NOT provide Primary Electrical to Sign. 120V 20A circuit.  
2. Junction box installed within Six (6) feet of Sign.  
3. Three Wire-Line, Ground, and Neutral, or licensed electrical contractor or licensed electrician.



This Document, and the information contained, is the property of Omega Sign & Lighting Inc. (the Company). By receipt of this Document, the holder agrees not to distribute to any other entities, nor reproduce this Document and the information contained, without the prior written approval by the Company. The Customer agrees that Omega Sign & Lighting Inc. will fabricate signs as per the above description and Customer agrees to all charges to fabricate sign(s) including permit & procurement fees & storage fees. The colors depicted in the rendering(s) are not an exact color match that will appear in the sign(s) construction, and exact color swatches can be provided only at the Customer's request.

**Siete 7 LLC**  
999 E Touhy Ave.  
Des Plaines, IL 60018

|                 |                  |
|-----------------|------------------|
| Date            | 11/10/25         |
| Acct. Executive | Lauren Valdez    |
| Sheet #         | 002              |
| Revision Number | Date             |
| 1               | 00/00/00         |
| 2               | 12/18/25         |
| 3               | 01/12/26         |
| 4               | 02/06/26         |
| 5               | 2/11/2026        |
| 6               | REV.7 - 03/11/26 |
| Drawn By        | D. Townson       |

**For Design Intent Only\*\***  
**SQC # 251622-07**

PERMIT INFO

|   |  |
|---|--|
| Sign Sq. Ft.                            |  |
| No. of Lamps/LEDs                       |  |
| Total Wattage                           |  |
| No. of Power Supplies                   |  |
| Total Amperage                          |  |
| Ext. 20 Amp Toggle Switch w/Rubber Boot |  |

|                   |           |      |
|-------------------|-----------|------|
| Approval          | Signature | Date |
| Cust. Approval    |           |      |
| Inspector         |           |      |
| Landlord Approval |           |      |

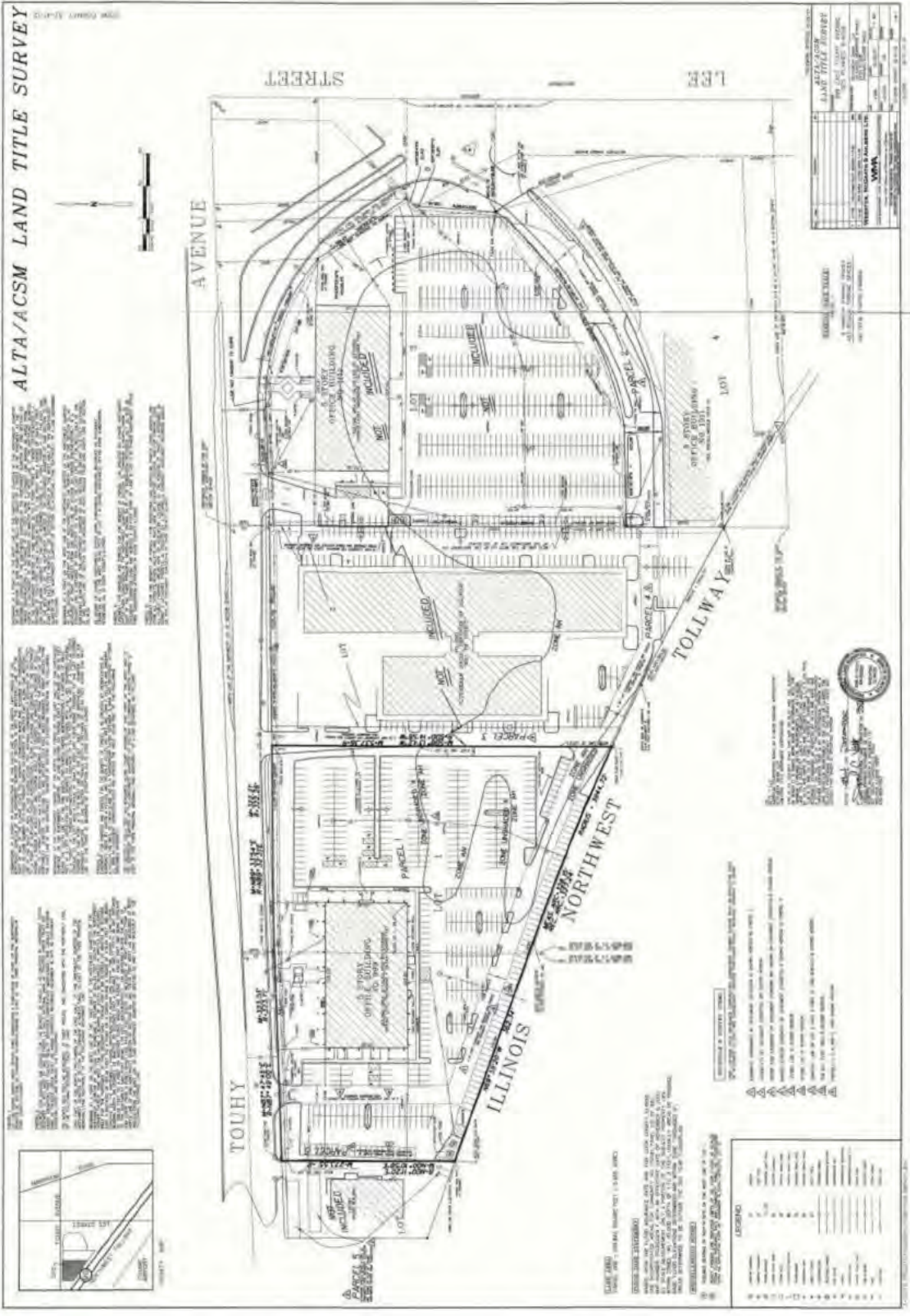

**ELECTRICAL NOTES**  
Each Sign Must Have:  
1. A minimum of One (1) dedicated 120V 20A circuit.  
2. Junction box installed within Six (6) feet of Sign.  
3. Three Wire: Line, Ground, and Neutral.



This Document, and the information contained, is the property of Omega Sign & Lighting Inc. (the Company). By receipt of this Document, the holder agrees not to distribute to any other entity, nor reproduce this Document and the information contained, without the prior written approval by the Company. The Customer agrees that Omega Sign & Lighting Inc. will fabricate signs as per the above rendering(s) and Customer agrees to all charges to fabricate sign(s) including permit & procurement fees & storage fees. The colors depicted in the rendering(s) are not an exact color match that will appear in the sign(s) construction, and exact color swatches can be provided only at the Customer's request.

**Siete 7 LLC**  
999 E Touhy Ave.  
Des Plaines, IL 60018

|                 |                  |
|-----------------|------------------|
| Date            | 11/10/25         |
| Acct. Executive | Lauren Valdez    |
| Sheet #         | 003              |
| Revision Number | Date             |
| △               | 00/00/00         |
| △               | 12/18/25         |
| △               | 01/12/26         |
| △               | 02/06/26         |
| △               | 2/11/2026        |
| △               | REV.7 - 03/11/26 |
| Drawn By        | D. Townson       |

**For Design Intent Only\*\***  
**SQC # 251622-07**

PERMIT INFO

|   |  |
|---|--|
| Sign Sq. Ft.                            |  |
| No. of Lamps/LEDs                       |  |
| Total Wattage                           |  |
| No. of Power Supplies                   |  |
| Total Amperage                          |  |
| Ext. 20 Amp Toggle Switch w/Rubber Boot |  |

|                   |      |
|-------------------|------|
| Approval          | Date |
| Cust. Approval    | Date |
| Inspector         | Date |
| Landlord Approval | Date |

**ELECTRICAL NOTES**

- Each Sign Must Have:
- A minimum of One (1) dedicated 120V 20A circuit.
  - Junction box installed within Six (6) feet of Sign.
  - Three Wire-Line, Ground, and Neutral.

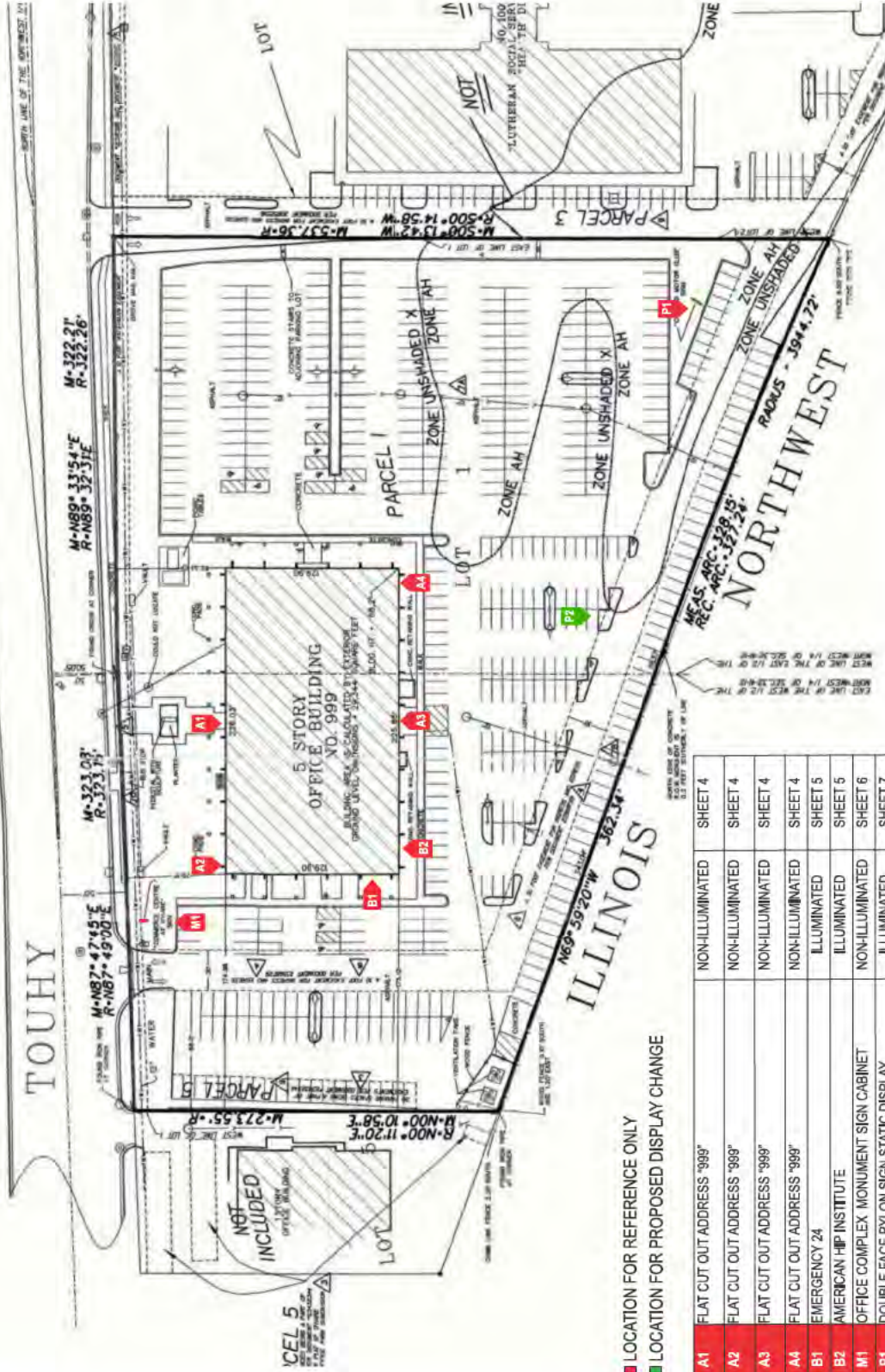

- LOCATION FOR REFERENCE ONLY
- LOCATION FOR PROPOSED DISPLAY CHANGE

| Color | Sign Type                              | Sign Type               |
|-------|--|-------------------------|
| A1    | FLAT CUT OUT ADDRESS "999"             | NON-ILLUMINATED SHEET 4 |
| A2    | FLAT CUT OUT ADDRESS "999"             | NON-ILLUMINATED SHEET 4 |
| A3    | FLAT CUT OUT ADDRESS "999"             | NON-ILLUMINATED SHEET 4 |
| A4    | FLAT CUT OUT ADDRESS "999"             | NON-ILLUMINATED SHEET 4 |
| B1    | EMERGENCY 24                           | ILLUMINATED SHEET 5     |
| B2    | AMERICAN HP INSTITUTE                  | ILLUMINATED SHEET 5     |
| M1    | OFFICE COMPLEX MONUMENT SIGN CABINET   | NON-ILLUMINATED SHEET 6 |
| P1    | DOUBLE FACE PYLON SIGN STATIC DISPLAY  | ILLUMINATED SHEET 7     |
| P2    | ANGLE PYLON SIGN WITH DIGITAL DISPLAYS | ILLUMINATED SHEET 8     |

This Document, and the information contained, is the property of Omega Sign & Lighting Inc. (the Company). By receipt of this Document, the holder agrees not to distribute to any other entities, nor reproduce this Document and the information contained, without the prior written approval by the Company. The Customer agrees that Omega Sign & Lighting Inc. will fabricate signs as per the above nomenclature and Customer agrees to all charges to fabricate sign(s) including permit & procurement fees & storage fees. The colors depicted in the nomenclature are not an exact color match that will appear in the sign(s) construction, and exact color swatches can be provided only at the Customer's request.

**Siete 7 LLC**  
999 E Touhy Ave.  
Des Plaines, IL 60018

|                 |                  |
|-----------------|------------------|
| Date            | 11/10/25         |
| Acct. Executive | Lauren Valdez    |
| Sheet #         | 004              |
| Revision Number | Date             |
| △               | 00/00/00         |
| △               | 12/18/25         |
| △               | 01/12/26         |
| △               | 02/06/26         |
| △               | 2/11/2026        |
| △               | REV.7 - 03/11/26 |
| Drawn By        | D. Townson       |

**\*\*For Design Intent Only\*\***  
**SQC # 251622-07**

|   |  |
|---|--|
| PERMIT INFO                             |  |
| Sign Sq. Ft.                            |  |
| No. of Lamps/LEDs                       |  |
| Total Wattage                           |  |
| No. of Power Supplies                   |  |
| Total Amperage                          |  |
| Ext. 20 Amp Toggle Switch w/Rubber Boot |  |

|                   |        |
|-------------------|--------|
| Approval          | Issued |
| Cust. Approval    | Date   |
| Approval          | Date   |
| Landlord Approval | Date   |

**FOR REFERENCE ONLY**

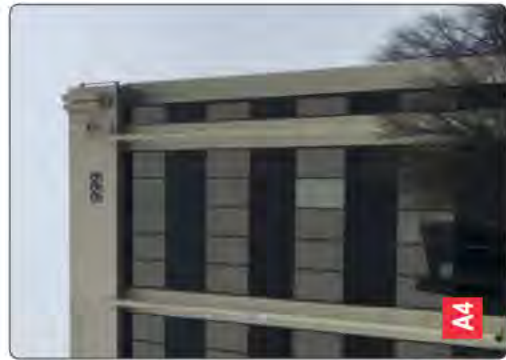

[A4] - FLAT CUT OUT LETTERS  
NON-ILLUMINATED

O.A.H.: 1'-6"  
O.A.W.: 3'-6"  
TOTAL SQ.FT.: 5.25

**FOR REFERENCE ONLY**



[A3] - FLAT CUT OUT LETTERS  
NON-ILLUMINATED

O.A.H.: 1'-6"  
O.A.W.: 3'-6"  
TOTAL SQ.FT.: 5.25

**FOR REFERENCE ONLY**



[A2] - FLAT CUT OUT LETTERS  
NON-ILLUMINATED

O.A.H.: 1'-6"  
O.A.W.: 3'-6"  
TOTAL SQ.FT.: 5.25

**FOR REFERENCE ONLY**

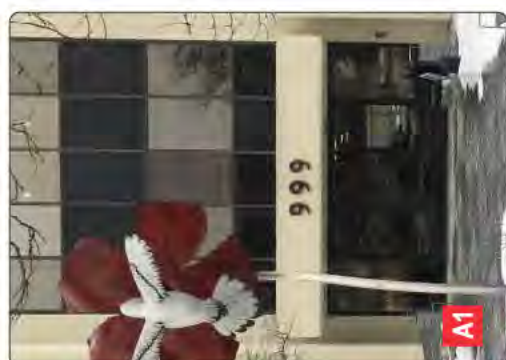

[A1] - FLAT CUT OUT LETTERS  
NON-ILLUMINATED

O.A.H.: 1'-6"  
O.A.W.: 3'-6"  
TOTAL SQ.FT.: 5.25

**FOR REFERENCE ONLY**

**ELECTRICAL NOTES**  
Each Sign Must Have:  
1. A minimum of One (1) dedicated Sign company DOES NOT provide Primary Electrical to Sign.  
2. Junction box installed within Six (6) feet of Sign.  
3. Three Wire-Line, Ground, and Neutral.



This Document, and the information contained, is the property of Omega Sign & Lighting Inc. (the Company). By receipt of this Document, the holder agrees not to distribute to any other entities, nor reproduce this Document and the information contained, without the prior written approval by the Company. The Customer agrees that Omega Sign & Lighting Inc. will fabricate signs as per the above nomenclature and Customer agrees to all charges to fabricate sign(s) including permit & procurement fees & storage fees. The colors depicted in the rendering(s) are not an exact color match that will appear in the sign(s) construction, and exact color swatches can be provided only at the Customer's request.

**Siete 7 LLC**  
999 E Touhy Ave.  
Des Plaines, IL 60018

|                 |                  |
|-----------------|------------------|
| Date            | 11/10/25         |
| Acct. Executive | Lauren Valdez    |
| Sheet #         | 005              |
| Revision Number | Date             |
| 2               | 00/00/00         |
| 3               | 12/18/25         |
| 4               | 01/12/26         |
| 5               | 02/06/26         |
| 6               | 2/11/2026        |
| 7               | REV.7 - 03/11/26 |
| Drawn By        | D. Townson       |

**\*\*For Design Intent Only\*\***  
**SQC # 251622-07**

PERMIT INFO

|   |  |
|---|--|
| Sign Sq. Ft.                            |  |
| No. of Lamps/LEDs                       |  |
| Total Wattage                           |  |
| No. of Power Supplies                   |  |
| Total Amperage                          |  |
| Ext. 20 Amp Toggle Switch w/Rubber Boot |  |

|                   |      |
|-------------------|------|
| Approved          | Date |
| Cust. Approval    | Date |
| Printed           | Date |
| Landlord Approval | Date |

**ELECTRICAL NOTES**  
Each Sign Must Have:  
1. A minimum of One (1) dedicated 120V 20A circuit.  
2. Junction box installed within Six (6) feet of Sign.  
3. Three Wire-Line, Ground, and Neutral.

**FOR REFERENCE ONLY**



[B1] - ILLUMINATED CHANNEL LETTERS  
"AMERICAN HIP INSTITUTE"

O.A.H.: 2'-6"  
O.A.W.: 51'-0"  
TOTAL SQ.FT.: 127.5

**FOR REFERENCE ONLY**



[B2] - ILLUMINATED CHANNEL LETTERS  
"EMERGENCY 24"

O.A.H.: 2'-6"  
O.A.W.: 27'-0"  
TOTAL SQ.FT.: 67.5

**FOR REFERENCE ONLY**

This Document, and the information contained, is the property of Omega Sign & Lighting Inc. (the Company). By receipt of this Document, the holder agrees not to distribute to any other entities, nor reproduce this Document and the information contained, without the prior written approval by the Company. The Customer agrees that Omega Sign & Lighting Inc. will fabricate signs as per the above nomenclature and Customer agrees to all charges to fabricate sign(s) including permit & procurement fees & storage fees. The colors depicted in the rendering(s) are not an exact color match that will appear in the sign(s) construction, and exact color swatches can be provided only at the Customer's request.



**FOR REFERENCE ONLY**



[M1] - OFFICE COMPLEX MONUMENT SIGN ILLUMINATED

18 FT. SETBACK FROM TOUHY AVE.

O.A.H.: 13'-0"  
O.A.W.: 5'-0"  
TOTAL SQ.FT.: 65

**FOR REFERENCE ONLY**

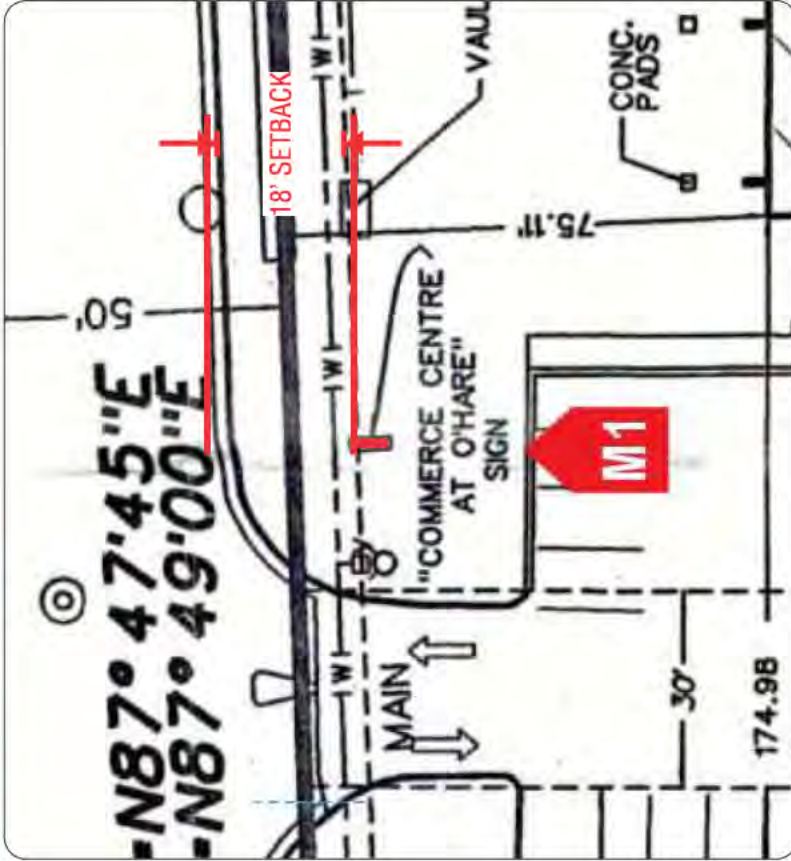

**Siete 7 LLC**  
999 E Touhy Ave.  
Des Plaines, IL 60018

|                 |                         |
|-----------------|-------------------------|
| Date            | 11/10/25                |
| Acct. Executive | Lauren Valdez           |
| Sheet #         | 006                     |
| Revision Number | Date                    |
| 1               | 00/00/00                |
| 2               | 12/18/25                |
| 3               | 01/12/26                |
| 4               | 02/06/26                |
| 5               | 2/11/2026               |
| 6               | <b>REV.7 - 03/11/26</b> |
| Drawn By        | D. Townson              |

**\*\*For Design Intent Only\*\***  
**SQC # 251622-07**

|   |  |
|---|--|
| PERMIT INFO                             |  |
| Sign Sq. Ft.                            |  |
| No. of Lamps/LEDs                       |  |
| Total Wattage                           |  |
| No. of Power Supplies                   |  |
| Total Amperage                          |  |
| Ext. 20 Amp Toggle Switch w/Rubber Boot |  |

|                   |               |
|-------------------|---------------|
| Approval          | _____<br>Date |
| Cust. Approval    | _____<br>Date |
| Approval          | _____<br>Date |
| Landlord Approval | _____<br>Date |

**ELECTRICAL NOTES**  
Each Sign Must Have:  
1. A minimum of One (1) dedicated 120V 20A circuit.  
2. Junction box installed within Six (6) feet of Sign.  
3. Three Wire: Line, Ground, and Neutral.



Sign company DOES NOT provide Primary Electrical to Sign. Power to the Sign must be done by a licensed electrical contractor or licensed electrician.

This Document, and the information contained, is the property of Omega Sign & Lighting Inc. (the Company). By receipt of this Document, the holder agrees not to distribute to any other entities, nor reproduce this Document and the information contained, without the prior written approval by the Company. The Customer agrees that Omega Sign & Lighting Inc. will fabricate signs as per the above rendering(s) and Customer agrees to all charges to fabricate sign(s) including permit & procurement fees & storage fees. The colors depicted in the rendering(s) are not an exact color match that will appear in the sign(s) construction, and exact color swatches can be provided only at the Customer's request.

**Siete 7 LLC**  
999 E Touhy Ave.  
Des Plaines, IL 60018

|                 |                  |
|-----------------|------------------|
| Date            | 11/10/25         |
| Acct. Executive | Lauren Valdez    |
| Sheet #         | 007              |
| Revision Number | Date             |
| △               | 00/00/00         |
| △               | 12/18/25         |
| △               | 01/12/26         |
| △               | 02/06/26         |
| △               | 2/11/2026        |
| △               | REV.7 - 03/11/26 |
| Drawn By        | D. Townson       |

**For Design Intent Only\*\***  
**SQC # 251622-07**

PERMIT INFO

|   |  |
|---|--|
| Sign Sq. Ft.                            |  |
| No. of Lamps/LEDs                       |  |
| Total Wattage                           |  |
| No. of Power Supplies                   |  |
| Total Amperage                          |  |
| Ext. 20 Amp Toggle Switch w/Rubber Boot |  |

|                   |      |
|-------------------|------|
| Approval          | Date |
| Cust. Approval    | Date |
| Approval          | Date |
| Landlord Approval | Date |

**Each Sign Must Have:**  
1. A minimum of One (1) dedicated 120V 20A circuit.  
2. Junction box installed within Six (6) feet of Sign.  
3. Three Wire-Line, Ground, and Neutral.

**FOR REFERENCE ONLY**

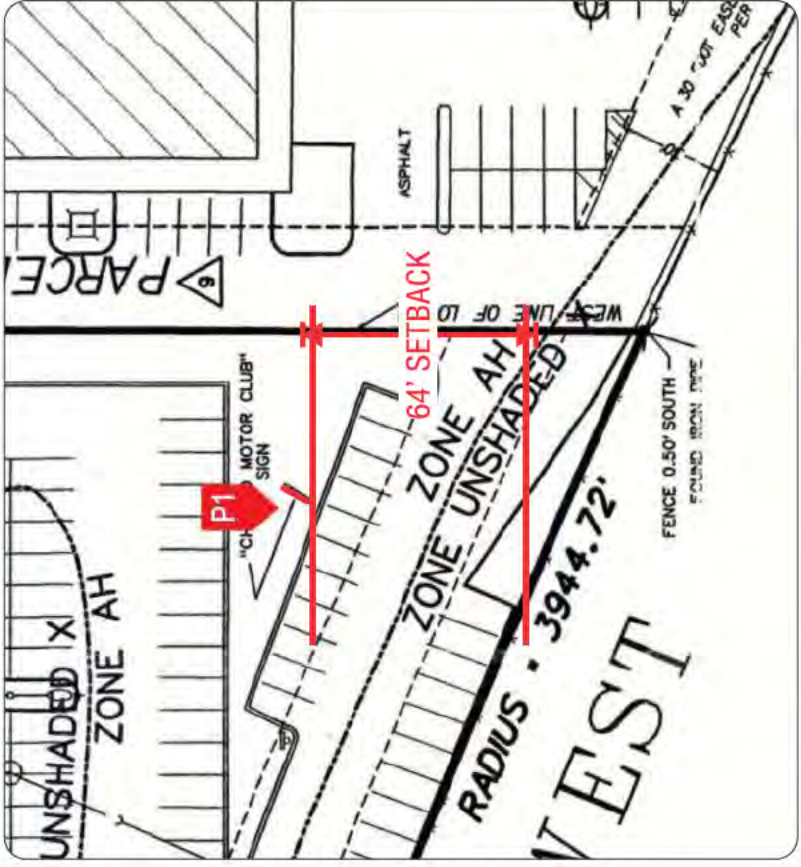

**[P1] - DOUBLE FACE PYLON SIGN STATIC DISPLAY ILLUMINATED**  
64 FT. SETBACK FROM FENCE  
33 FT. BEYOND FENCE TO EXPRESSWAY WALL

O.A.H.: 13'-0"  
O.A.W.: 5'-0"  
TOTAL SQ.FT.: 65

**FOR REFERENCE ONLY**

This Document, and the information contained, is the property of Omega Sign & Lighting Inc. (the Company). By receipt of this Document, the holder agrees not to distribute to any other entities, nor reproduce this Document and the information contained, without the prior written approval by the Company. The Customer agrees that Omega Sign & Lighting Inc. will fabricate signs as per the above nomenclature and Customer agrees to all charges to fabricate sign(s) including permit & procurement fees & storage fees. The colors depicted in the rendering(s) are not an exact color match that will appear in the sign(s) construction, and exact color swatches can be provided only at the Customer's request.



**Siete 7 LLC**  
999 E Touhy Ave.  
Des Plaines, IL 60018

|                 |                         |
|-----------------|-------------------------|
| Date            | 11/10/25                |
| Acct. Executive | Lauren Valdez           |
| Sheet #         | 008                     |
| Revision Number | Date                    |
| △               | 00/00/00                |
| △               | 12/18/25                |
| △               | 01/12/26                |
| △               | 02/06/26                |
| △               | 2/11/2026               |
| △               | <b>REV.7 - 03/11/26</b> |
| Drawn By        | D. Townson              |

**\*\*For Design Intent Only\*\***  
**SQC # 251622-07**

PERMIT INFO

|   |      |
|---|------|
| Sign Sq. Ft.                            |      |
| No. of Lamps/LEDs                       |      |
| Total Wattage                           |      |
| No. of Power Supplies                   |      |
| Total Amperage                          |      |
| Ext. 20 Amp Toggle Switch w/Rubber Boot |      |
| Approval                                | Date |
| Cust. Approval                          | Date |
| Approval                                | Date |
| Landlord Approval                       | Date |

**Each Sign Must Have:**  
1. A minimum of One (1) dedicated 120V 20A circuit.  
2. Junction box installed within Six (6) feet of Sign.  
3. Three Wire-Line, Ground, and Neutral.

**INSET PLAN SIGN P2**

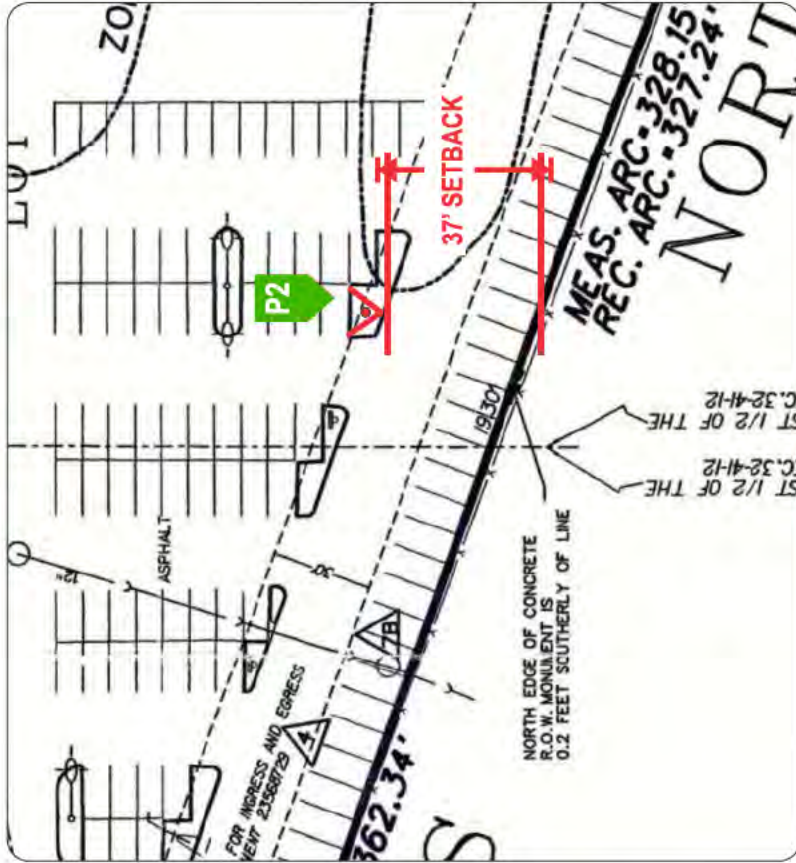

**[P2] - ANGLE PYLON SIGN WITH DIGITAL DISPLAYS ILLUMINATED**

37 FT. SETBACK FROM FENCE  
33 FT. BEYOND FENCE TO EXPRESSWAY WALL

**EXISTING**

O.A.H.: 21'-8"  
O.A.W.: 22'-6 1/2"  
TOTAL SQ.FT.: 488.40

**PROPOSED**

O.A.H.: 27'-0.05"  
O.A.W.: 23'-1.2"  
TOTAL SQ.FT.: 508.29

- Ledman 8MM
- Double Sided - V-Shape
- Matrix 756 x 792
- Cabinet / Viewing 22'-0.5"H x 23'-1.2" W
- Novastar Controller
- Cloud Based Software
- Cellular & Data Plan - 10yr Opti-Connect

**ELECTRICAL NOTES**

Sign company DOES NOT provide Primary Electrical to Sign. Power to the Sign must be done by a licensed electrical contractor or licensed electrician.



**LANDSCAPE PLAN**

**Aerial View**



**Qty. (4) Boxwood Baby Gem Bushes**



**Qty. (4) Elijah Blue Fescue Ornamental Grass**



= Baby Gem Bushes



= Elijah Blue Fescue

**Brown Mulch**



**Siete 7 LLC**  
999 E Touhy Ave.  
Des Plaines, IL 60018

|                 |                         |
|-----------------|-------------------------|
| Date            | 11/10/25                |
| Acct. Executive | Lauren Valdez           |
| Sheet #         | 009                     |
| Revision Number | Date                    |
| 1               | 00/00/00                |
| 2               | 12/18/25                |
| 3               | 01/12/26                |
| 4               | 02/06/26                |
| 5               | 2/11/2026               |
| 6               | <b>REV.7 - 03/11/26</b> |

Drawn By **D. Townson**

**\*\*For Design Intent Only\*\***  
**SQC # 251622-07**

PERMIT INFO

|   |  |
|---|--|
| Sign Sq. Ft.                            |  |
| No. of Lamps/LEDs                       |  |
| Total Wattage                           |  |
| No. of Power Supplies                   |  |
| Total Amperage                          |  |
| Ext. 20 Amp Toggle Switch w/Rubber Boot |  |

|                   |           |      |
|-------------------|-----------|------|
| Approvals         | Signature | Date |
| Cust. Approval    |           |      |
| Inspector         |           |      |
| Landlord Approval |           |      |

**ELECTRICAL NOTES**

- Each Sign Must Have:**
1. A minimum of One (1) dedicated Sign company DOES NOT provide Primary Electrical to Sign. Power to the Sign must be done by a licensed electrical contractor or licensed electrician.
  2. Junction box installed within Six (6) feet of Sign.
  3. Three Wire: Line, Ground, and Neutral.



This Document, and the information contained, is the property of Omega Sign & Lighting Inc. (the Company). By receipt of this Document, the holder agrees not to distribute to any other entities, nor reproduce this Document and the information contained, without the prior written approval by the Company. The Customer agrees that Omega Sign & Lighting Inc. will fabricate signs as per the above rendering(s) and Customer agrees to all charges to fabricate sign(s) including permit & procurement fees & storage fees. The colors depicted in the rendering(s) are not an exact color match that will appear in the sign(s) construction, and exact color swatches can be provided only at the Customer's request.

**EXHIBIT C**

**UNCONDITIONAL AGREEMENT AND CONSENT**

**TO:** The City of Des Plaines, Illinois ("*City*");

**WHEREAS**, ALM 7 LCC and DPM LLC (collectively, the "*Petitioner*") are the owners of the property commonly known as 999 E. Touhy Avenue ("*Subject Property*"), which is located in the City; and

**WHEREAS**, the Petitioner proposes to replace an existing electronic message board ("*EMB*") with a new, larger two-sided EMB monument sign on the Subject Property ("*Proposed EMB*"); and

**WHEREAS**, Ordinance No. Z-8-26 adopted by the City Council of the City of Des Plaines on \_\_\_\_\_, 2026 ("*Ordinance*"), grants approval of the Requested Relief to allow the installation of the Proposed EMB on the Subject Property, subject to certain conditions; and

**WHEREAS**, Petitioner desires to evidence to the City its unconditional agreement and consent to accept and abide by each of the terms, conditions, and limitations set forth in the Ordinance, and the Petitioner desires to evidence its consent to recording the Ordinance against the Subject Property;

**NOW, THEREFORE**, Petitioner does hereby agree and covenant as follows:

1. Petitioner shall, and does hereby, unconditionally agree to, accept, consent to and abide by all of the terms, conditions, restrictions, and provisions of the Ordinance.
2. Petitioner acknowledges and agrees that the City is not and shall not be, in any way, liable for any damages or injuries that may be sustained as a result of the City's review and approval of any plans for the Subject Property, or the adoption of the Ordinance or the issuance of any permits for the use and development of the Subject Property, and that the City's review and approval of the Ordinance and any such plans and issuance of any such permits does not, and shall not, in any way, be deemed to insure Petitioner against damage or injury of any kind and at any time.
3. Petitioner acknowledges that the public notices and hearings have been properly given and held with respect to the adoption of the Ordinance, has considered the possibility of the revocation provided for in the Ordinance, and agrees not to challenge any such revocation on the grounds of any procedural infirmity or any denial of any procedural right, provided that the procedures required by Section 12-4-7 of the City's Zoning Ordinance are followed.
4. Petitioner agrees to and does hereby hold harmless and indemnify the City, the City's corporate authorities, and all City elected and appointed officials, officers, employees, agents, representatives, and attorneys, from any and all claims that may,

at any time, be asserted against any of such parties in connection with: (a) the City's review and approval any plans and issuance of any permits, (b) the approval of the Ordinance including the procedures followed in connection with the adoption of the Ordinance, (c) the development, construction, maintenance, and use of the Subject Property, and (d) the performance by Petitioner of its obligations under this Unconditional Agreement and Consent.

- 5. Petitioner shall, and does hereby agree to, pay all expenses incurred by the City in defending itself with regard to any and all of the claims mentioned in this Unconditional Agreement and Consent. These expenses shall include all out-of-pocket expenses, such as attorneys' and experts' fees, and shall also include the reasonable value of any services rendered by any employees of the City.

ATTEST:

**ALM 7 LLC**

By: \_\_\_\_\_

By: \_\_\_\_\_

ATTEST:

**DPM LLC**

By: \_\_\_\_\_

By: \_\_\_\_\_



COMMUNITY AND ECONOMIC DEVELOPMENT DEPARTMENT

1420 Miner Street
Des Plaines, IL 60016
P: 847.391.5380
desplainesil.gov

MEMORANDUM

Date: April 23, 2026
To: Dorothy Wisniewski, City Manager
From: Jonathan Stytz, AICP, Senior Planner JS
Cc: Jonathan Mendel, AICP, Assistant Director of Community & Economic Development JM
Subject: Consideration of an Ordinance Approving a Conditional Use for a Commercial School for Central Scholar Academy at 1585 Ellinwood Street, Suite 106, Case #26-009-CU (2nd Ward)

Issue: The petitioner requests a conditional use for a Commercial School in the C-5 Central Business district at 1585 Ellinwood Street, Suite 106.

Petitioner: Central Scholar Academy (Representative: Wilsa Dela Cruz Cabrera, 1585 Ellinwood Street, Suite 106, Des Plaines, IL 60016)

Owner: DZ 1585 LLC (Representative: Lucas Fuksa, 102 Main Street, Suite 200, Park Ridge, IL 60068)

Case Number: #26-009-CU

PINs: 09-17-421-033-0000 and 09-17-421-028-0000

Ward Number: #2, Alderman Colt Moylan

Existing Zoning: C-5, Central Business

Existing Land Use: Multi-Tenant Commercial Building with Off-Street Parking Area

Surrounding Zoning: North: C-5, Central Business District
South: C-5, Central Business District
East: C-5, Central Business District
West: C-5, Central Business District

Surrounding Land Uses: North: Religious Institution (commercial)
South: Senior Living Facility (commercial)
East: Senior Living Facility (commercial)
West: Vacant building (former restaurant)

- Street Classification:** Ellinwood Street is classified as a *local road* under City of Des Plaines jurisdiction.
- Comprehensive Plan:** The Comprehensive Plan designates this site as *Higher Density Urban Mix with Residential*.
- Property/Zoning History:** The subject property was annexed into the City in 1870 as a single family residence<sup>1</sup>. Around 1972, the subject property was redeveloped with a commercial building. Today, the subject property consists of an off-street parking area and multi-tenant office building, which consists of predominantly office uses with a single retail establishment also operating on site. Based on City records, there are existing items to address related to elevator inspections and an expired sign permit, which both must be addressed to comply with all current regulations.

### CONDITIONAL USE

**Request Description:**

*Overview*

The petitioner requests a conditional use to operate a commercial school as described in the attached Project Narrative. A commercial school, as defined below, is a conditional use in the C-5 district.

COMMERCIAL SCHOOL: An establishment, the principal use or purpose of which is teaching the skills needed to perform a particular professional job or trade including, but not limited to, schools of construction or building trade, cosmetology, cooking, motor vehicle repair, computer training facilities, vocational schools, administrative business training facilities and similar fields. "Commercial schools" do not include any use otherwise listed specifically in a zoning district as a permitted or conditional use. (Section 12-13-3 of the Zoning Ordinance).

The subject property is currently a two-story, approximately 5,000-square-foot multi-tenant office building and off-street parking area in the rear as illustrated on the attached ALTA/ACSM Land Title Survey. The commercial school would occupy the far eastern tenant space on the first level of the building without any proposed exterior and interior changes to the building itself.

*Proposed Operations*

Based on the attached Project Narrative, this use would provide a supervised skills performance evaluation on site for up to 20 hours as part of an educational healthcare training program to prepare students to become Certified Nursing Assistants (CNAs) in the State of Illinois. This use is anticipated to operate Wednesday through Sunday from 4:00 P.M. to 8:00 P.M. for the supervised performance skills evaluation and Monday and Tuesday only by appointment as specified in the attached Project Narrative. Each course will not exceed 12 students and one instructor minimizing daily traffic and parking needs during the week. See the attached Project Narrative and attached Program Schedule for additional information.

---

<sup>1</sup> <https://www.historicaerials.com/location/41.625/-87.875/T1890/16>. Retrieved April 7, 2026.

### *Floor Plans*

The existing tenant space where the commercial school use is proposed is approximately 628 square feet in area consisting of a classroom, two simulation rooms, a reception area, break room, and equipment/storage space as illustrated in the attached Floor Plan. The table below has been provided by the petitioner to illustrate the area, use, and occupancy of all rooms within the tenant space. Please see the attached Program Schedule for additional information.

| <b>Proposed Floor Plan Spaces</b> |                               |                  |                       |
|-----------------------------------|-------------------------------|------------------|-----------------------|
| <b>Space ID</b>                   | <b>Use</b>                    | <b>Area (SF)</b> | <b>Occupancy Load</b> |
| Classroom                         | Educational Classes           | 163.61 SF        | 8 persons             |
| Simulation Room #1                | Skills Performance Evaluation | 103.28 SF        | 2 persons             |
| Simulation Room #2                | Skills Performance Evaluation | 111.17 SF        | 2 persons             |
| Equipment Storage                 | Storage                       | 90.25 SF         | 1 person              |
| Reception and Library             | Business / Reception          | 105.25 SF        | 3 persons             |
| Break Room                        | Accessory / Staff Break Room  | 54.65 SF         | 1 person              |
| <b>Totals</b>                     |                               | <b>628.21 SF</b> | <b>17 persons</b>     |

### *Access and Circulation*

The rear surface parking lot on the subject property is currently only accessed via a permanent and perpetual vehicle ingress and egress easement through a portion of the Brookfield Senior Living property at 800 S. Des Plaines River Road off Ellinwood Street. This easement is located just east of the subject property as illustrated in the attached ALTA/ACSM Land Title Survey and is not subject to change with this request. The proposed commercial school will have limited classes throughout the week with no more than one class at the same time and no more than ten students in each class. As a result, there is no concern from staff that the existing off-street parking area and access drive will suffice for access and circulation.

### *Off-Street Parking*

The subject property contains 25 off-street parking spaces including one accessible space. As noted in the definition above, multi-tenant office buildings are required to adhere to the minimum off-street parking space requirement for offices as identified in Section 12-9-7 of the Zoning Ordinance. Offices require a minimum of one off-street parking space for every 250 square feet of gross floor area. Based on the floor area definition, a minimum of two off-street parking spaces including one accessible space are required for Suite 106, which is satisfied by the existing parking on the subject property. Further, the petitioner notes in the attached Project Narrative that limited courses will be provided during the week and all other visitors will access the site on an appointment-only basis minimizing the overall traffic generated from this use.

It is important to note that based on the floor plans provided, approximately 9,180 square feet for the entire multi-tenant office building is factored into the parking calculation resulting in a total of 37 required off-street parking spaces for the subject property. However, pursuant to Section 12-9-2 of the Zoning Ordinance, no additional parking is required since the use of the building as a multi-tenant office building will not change with the proposed conditional use.

### **Planning and Zoning Board (PZB) Recommendation**

The PZB held a public hearing on April 14, 2026 to consider the request and voted 5-0 to recommend that City Council approve the conditional use and major variation requests. The rationale for the PZB's vote is captured in the attached excerpt of minutes from the April 14, 2026 PZB Meeting.

### **City Council Action**

Pursuant to Section 12-3-4.D.4 of the Zoning Ordinance, the City Council has the final authority on the conditional use request. The Council may approve, approve with modifications, or deny Ordinance Z-9-26, which includes the requested conditional use for a commercial school on the subject property. There are no staff recommended conditions of approval.

### **Attachments:**

- Attachment 1: Location Map
- Attachment 2: Site and Context Photos
- Attachment 3: Photos of Existing Conditions
- Attachment 4: ALTA/ACSM Land Title Survey
- Attachment 5: Petitioner's Responses to Standards
- Attachment 6: Acting Chairman Catalano PZB Recommendation Letter
- Attachment 7: Excerpt of Minutes from the April 14, 2026 PZB Meeting

### **Ordinance Z-9-26**

- Exhibit A: Project Narrative
- Exhibit B: Program Schedule
- Exhibit C: Floor Plan
- Exhibit D: Unconditional Agreement and Consent

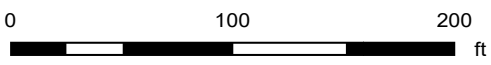
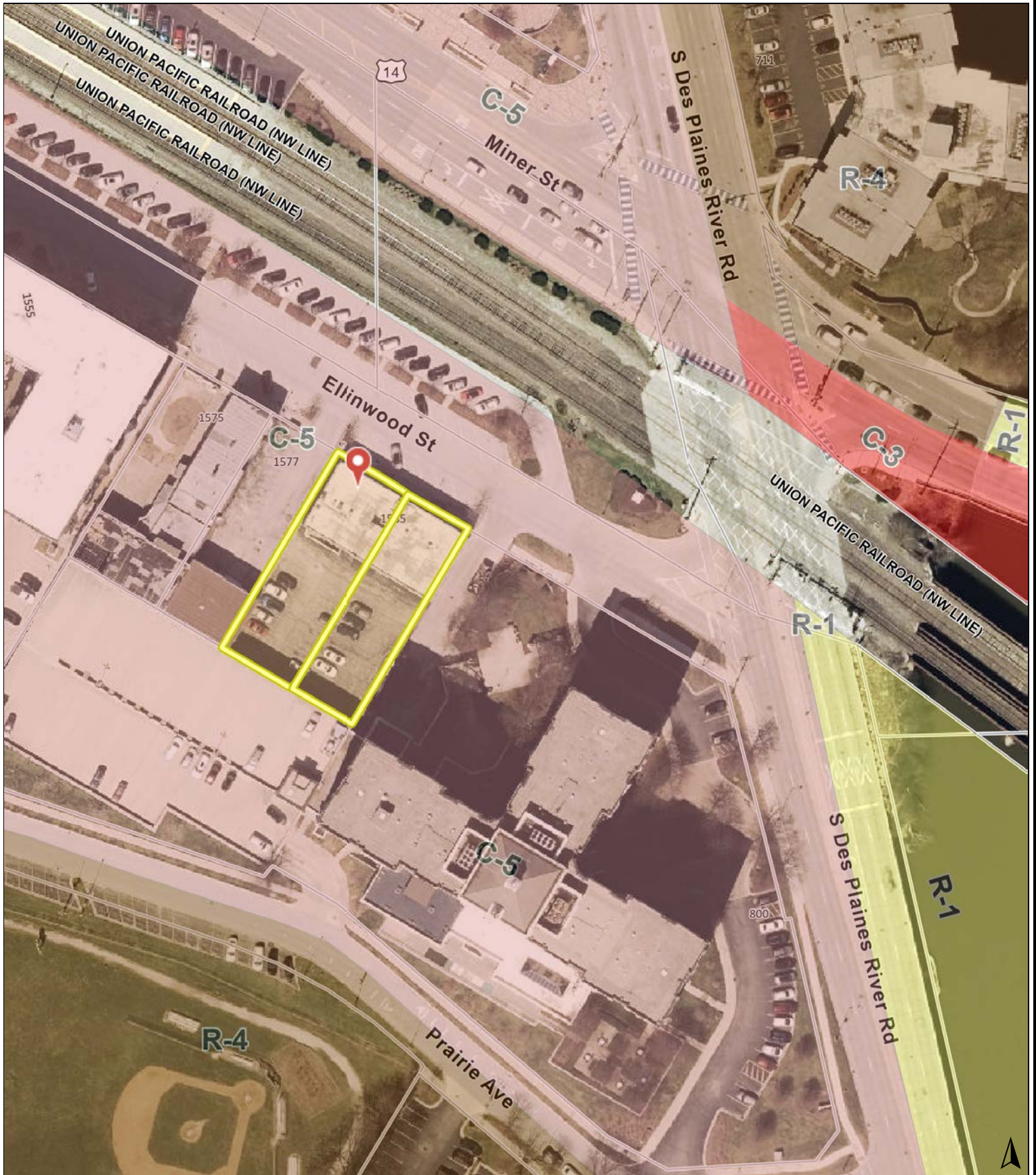

Print Date: 4/10/2026

Notes

Disclaimer: The GIS Consortium and MGP Inc. are not liable for any use, misuse, modification or disclosure of any map provided under applicable law. This map is for general information purposes only. Although the information is believed to be generally accurate, errors may exist and the user should independently confirm for accuracy. The map does not constitute a regulatory determination and is not a base for engineering design. A Registered Land Surveyor should be consulted to determine precise location boundaries on the ground.



1585 Elinwood Street – Facing Southeast at Front of Building



1585 Elinwood Street – Facing South from Elinwood Street



1585 Elinwood Street – Public Notice Sign



1585 Elinwood Street – Facing Southwest at Front Entrance



1585 Ellinwood Street – View of Front On-Street Parking Area



1585 Ellinwood Street – View of Rear of Building



1585 Ellinwood Street – View of Rear Parking Area



1585 Ellinwood Street – Facing South at Ingress/Egress Easement









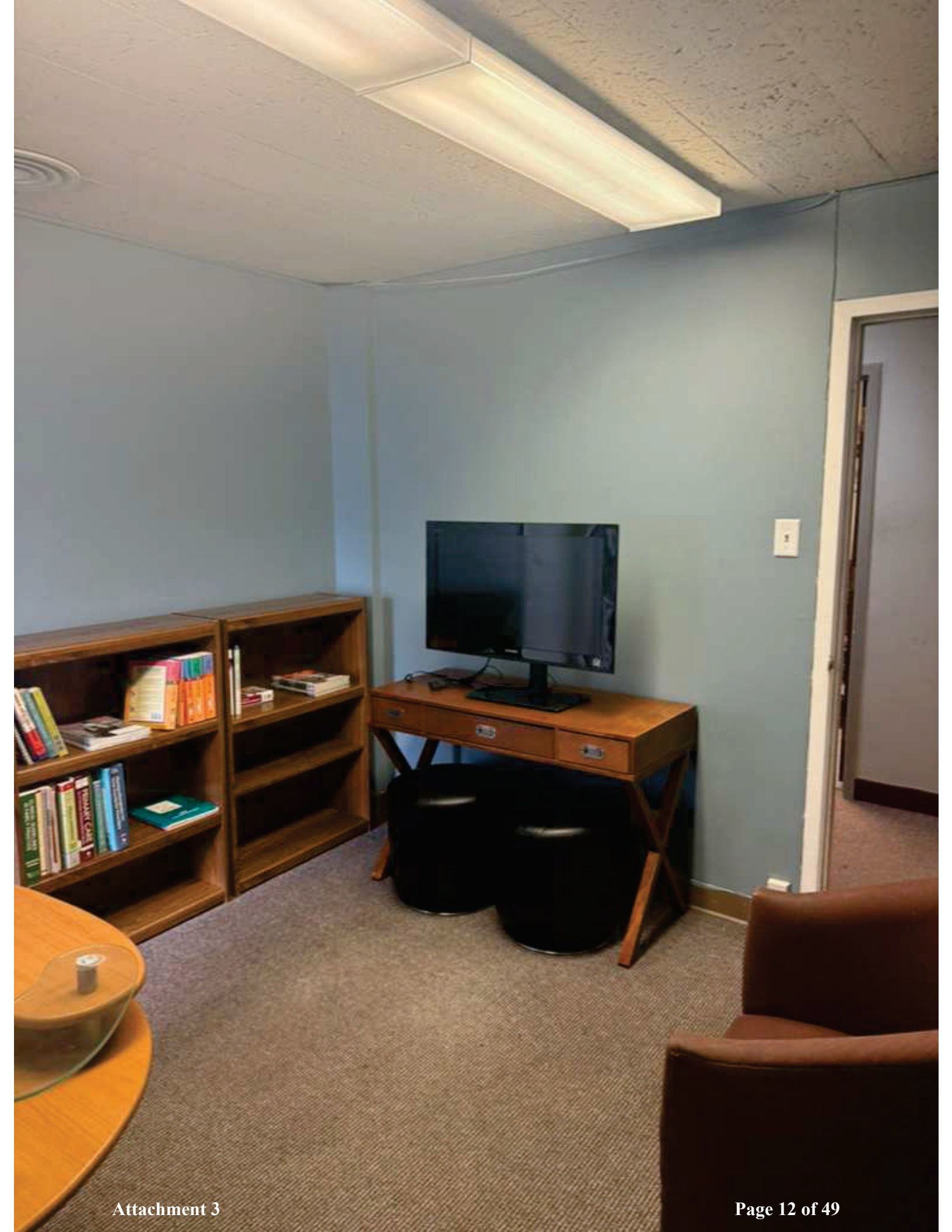

# GREMLEY & BIEDERMANN, INC.

PROFESSIONAL ILLINOIS LAND SURVEYORS

4505 N. Elston Avenue Chicago, Illinois 60630  
 Telephone: (773) 685-5102 Fax: (773) 286-4184  
 Illinois Land Surveyor Corporation No. 16  
 License No. 184-002761

## Plat of Survey ALTA / ACSM Land Title Survey

PARCEL 1:  
 THE NORTHEASTERLY 150.0 FEET OF LOTS 103 AND 104 IN THE TOWN OF RAND (NOW THE CITY OF DES PLAINES), BEING A SUBDIVISION OF PART OF SECTIONS 16, 17, 20 AND 21, TOWNSHIP 41 NORTH, RANGE 12, EAST OF THE THIRD PRINCIPAL MERIDIAN, IN COOK COUNTY, ILLINOIS.

PARCEL 2:  
 PERMANENT AND PERPETUAL EASEMENT FOR THE BENEFIT OF PARCEL 1 AS DISCLOSED BY DEED FROM CITY OF DES PLAINES TO RIVER OAKS PARTNERS DATED JUNE 2, 1992 AND RECORDED JUNE 5, 1992 AS DOCUMENT 92396888 AND CREATED BY DEED FROM GARFIELD RIDGE TRUST AND SAVINGS BANK, AS TRUSTEE UNDER TRUST NUMBER 69813 TO RICHARD E. VAN STOCKUM AND KRISTINE M. VAN STOCKUM, AS TO AN UNDIVIDED 1/2 INTEREST AND RANGVALD T. THOMPSON, AS TO AN UNDIVIDED 1/2 INTEREST DATED JUNE 24, 1993 AND RECORDED JUNE 24, 1993 AS DOCUMENT 93482922, FOR THE PURPOSE OF VEHICULAR INGRESS AND EGRESS OVER THE FOLLOWING DESCRIBED PROPERTY:

THE WEST 25.0 FEET OF THE NORTH 105.0 FEET OF LOT 105 IN TOWN OF RAND, A SUBDIVISION OF THE SOUTH 1/2 OF THE SOUTHWEST 1/4 OF SECTION 16, PART OF THE EAST 1/2 OF THE SOUTHWEST 1/4 OF SECTION 17, THE NORTHEAST 1/4 OF SECTION 20, THE NORTHWEST 1/4 OF SECTION 21, ALL IN TOWNSHIP 41 NORTH, RANGE 12 EAST OF THE THIRD PRINCIPAL MERIDIAN, IN COOK COUNTY, ILLINOIS.

### LEGEND

- Storm CB
- Storm Inlet
- Unclassified Manhole
- Electric Light Pole
- Water Buffalo Box
- Tree - Deciduous

NOTE: INREGARDS TO ADJOINING PROPERTY OWNERS, NAMES WERE NOT SHOWN AS THEY WERE NOT FURNISHED AS SPECIFIED IN ALTA/ACSM REQUIREMENTS OF 1999.

THIS SURVEY IS SUBJECT TO ALL RESTRICTIONS & MATTERS APPEARING OF PUBLIC RECORD AS MIGHT BE DISCLOSED BY A CURRENT TITLE COMMITMENT.

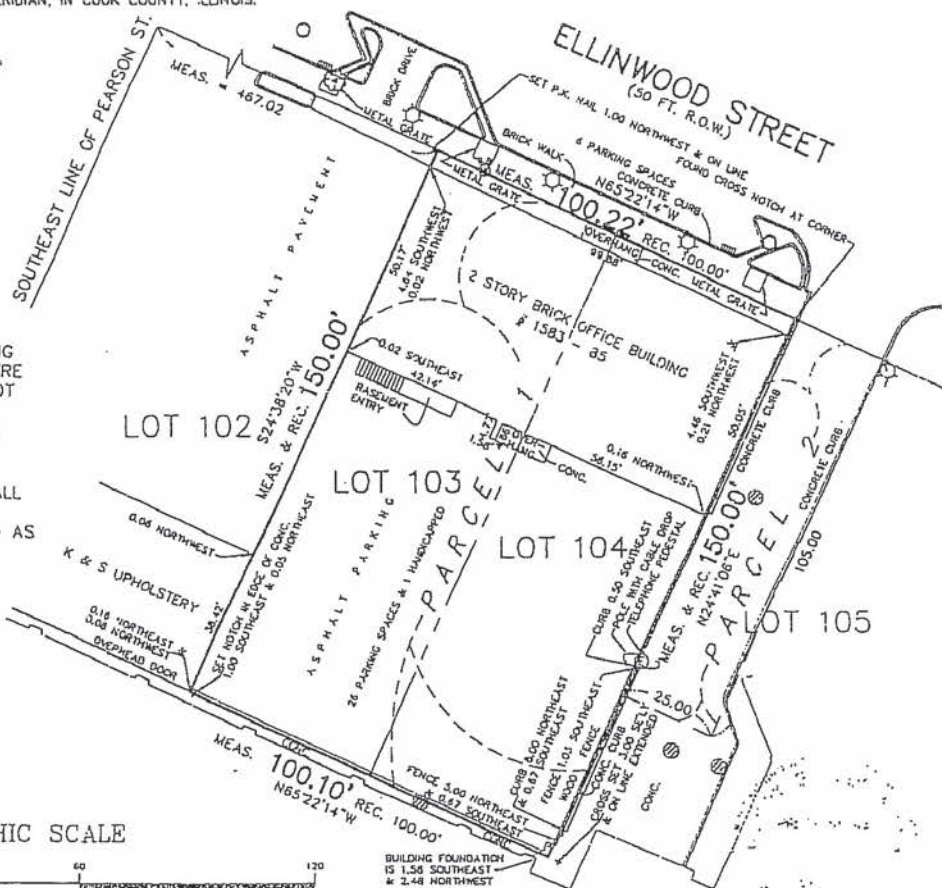

### GRAPHIC SCALE



( IN FEET )  
 1 inch = 30 ft

LAND AREA = 15024 SQ.FT. OR 0.345 ACRES  
 PROPERTY IS WITHIN ZONE X, AREAS DETERMINED TO BE OUTSIDE 500 YEAR FLOODPLAIN, AS PER INSURANCE RATE MAP COOK COUNTY, ILLINOIS, COMMUNITY PANEL NO. 17031C 0217F EFFECTIVE DATE NOV 6, 2000.

Distances are marked in feet and decimal parts thereof. Compare all points BEFORE building by same and at once report any differences BEFORE damage is done.

For easements, building lines and other restrictions not shown on survey plat refer to your abstract, deed, contract, title policy and local building line regulations.

NO dimensions shall be assumed by scale measurement upon this plat.

Unless otherwise noted hereon the Bearing, Bats, Elevation Datum and Coordinate Datum is used is ASSUMED.

COPYRIGHT GREMLEY & BIEDERMANN, INC. 2002

State of Illinois)  
 County of Cook)ss

This is to certify to 1585 Ellinwood LLC, an Illinois limited liability Company, Metropolitan Bank and Trust Company, its successors and/or assigns, Chicago Title Insurance Company and Schiff Hardin & Walte, that this map or plat and the survey on which it is based were made in accordance with "Minimum Standard Detail Requirements and Classifications for ALTA/ACSM Land Title Surveys," jointly established and adopted by ALTA, ACSM and NSPS in 1999. Pursuant to the Accuracy Standards as adopted by ALTA and ACSM and in effect on the date of this certification, undersigned further certifies that the Positional Uncertainties resulting from the survey measurements made on the survey do not exceed the allowable Positional Tolerance.

Field measurements completed on JUNE 27, 2002.

Signed on SEPT. 20, 2002

By: [Signature]

Professional Illinois Land Surveyor No. 2702

My License Expires November 30, 2002

This professional service conforms to the current

REVISED: 09-20-2002 ADD CERT. NAMES (G.L)

|         |       |
|---------|-------|
| Checked | Drawn |
| JB      | RS    |

1021088

ORDER NO. 1021088  
 SCALE: 1 inch = 30 Feet  
 DATE: JUNE 27, 2002  
 ADDRESS: 1583-85 ELLINWOOD ST., DES PLAINES  
 ORDERED BY: ROBERT W. SINGER

Attachment 4

## STANDARDS FOR CONDITIONAL USES

**The Planning and Zoning Board and City Council review the particular facts and circumstances of each proposed Conditional Use in terms of the following standards.** Keep in mind that in responding to the items below, you are demonstrating that the proposed use is appropriate for the site and will not have a negative impact on surrounding properties and the community. Please answer each item completely and thoroughly (two to three sentences each).

1. The proposed conditional use is in fact a conditional use established within the specific zoning district involved;

The proposed Basic Nursing Assistant Training Program (BNATP) constitutes an educational and vocational training use, which is identified as a conditional use within the C-5 Central Business District under the applicable zoning ordinance.

The proposed use is instructional in nature and will operate entirely within an existing commercial tenant space, with no exterior alterations. The request meets the intent of the C-5 district and satisfies the general standards for conditional uses as follows:

### **Compatibility with Surrounding Uses:**

The program is consistent with the commercial and service-oriented character of the C-5 district. The instructional use is low-intensity and comparable to other permitted office, educational, and professional uses within the area.

### **Traffic and Parking Impact:**

The use generates minimal traffic due to small class sizes, limited onsite hours, and staggered scheduling. Only one cohort is onsite at a time, and many students utilize public transportation. Parking is accommodated within designated onsite areas, ensuring no adverse impact on surrounding properties.

### **Public Health, Safety, and Welfare:**

The program operates in compliance with Illinois Department of Public Health requirements, including a strict instructor-to-student ratio and regulated training standards. The use does not involve hazardous materials, high noise levels, or activities that would negatively affect public safety.

### **Operational Characteristics:**

The program operates during off-peak hours with limited daily occupancy. All instruction is conducted indoors, and the majority of coursework is delivered virtually, further reducing onsite activity.

### **Consistency with Zoning Intent:**

The proposed use supports workforce development and educational advancement, which aligns with the broader goals of the C-5 district to accommodate a mix of commercial, professional, and service-related uses that serve the community.

2. The proposed conditional use is in accordance with the objectives of the city's comprehensive plan and this title;

The proposed use is consistent with the City's Comprehensive Plan goals, which support workforce development and community-serving institutional uses. The program provides job training for an in-demand healthcare occupation while maintaining a low-impact operational profile. The use aligns with the intent of this title and the purpose of the C-5 district.

3. The proposed conditional use is designed, constructed, operated, and maintained so as to be harmonious and appropriate in appearance with the existing or intended character of the general vicinity;

The proposed use will operate entirely within an existing commercial building and will not require exterior modifications. All instructional activities occur indoors and on a limited schedule. The use is compatible with the surrounding commercial, office, and professional development in the area.

4. The proposed conditional use is not hazardous or disturbing to existing neighboring uses; The proposed program does not involve hazardous materials, industrial activities, or medical treatment services. Operations are limited in scope and duration and generate minimal noise or disruption. The use will not adversely affect adjacent properties or uses.

5. The proposed conditional use is to be served adequately by essential public facilities and services such as highways, streets, police and fire protection, drainage structures, refuse disposal, water and sewer, and schools; or the persons or agencies responsible for the establishment of the proposed conditional use shall provide adequately any such services; The subject property is adequately served by existing public facilities and services, including streets, utilities, police and fire protection, water, sewer, and refuse services. The proposed use will not significantly increase demand for these services. No additional public improvements are required.

6. The proposed conditional use does not create excessive additional requirements at public expense for public facilities and services and not be detrimental to the economic welfare of the community;

The proposed use will operate within an existing building and does not require additional public expenditures or infrastructure expansion. The program contributes positively to the local economy by supporting workforce readiness in the healthcare sector. The use is not detrimental to the community's economic welfare.

7. The proposed conditional use does not involve uses, activities, processes, materials, equipment and conditions of operation that will be detrimental to any persons, property,

or the general welfare by reason of excessive production of traffic, noise, smoke, fumes, glare or odors;

The proposed use will not result in excessive traffic, noise, smoke, odors, or other nuisances. There are no outdoor activities, late-night operations, or operational impacts that would affect surrounding properties. The use is consistent with public health, safety, and welfare standards.

8. The proposed conditional use provides vehicular access to the property designed that does not create an interference with traffic on surrounding public thoroughfares; Existing vehicular access and parking facilities are sufficient to accommodate the proposed use. On-site activity is limited to approximately four hours per week with small class sizes. The use is not expected to create traffic congestion or interfere with public thoroughfares.

### **Anticipated Daily Visitor Traffic**

The proposed use of the site in Des Plaines will occur during off-peak hours, which further supports minimal impact on surrounding traffic patterns. Based on the program's structure and limited onsite activity, traffic is expected to remain low and well controlled.

Each session will include approximately 8 students, with a maximum of 10 students per session, in compliance with program and regulatory requirements. In addition, one instructional staff member will be present per session.

Because sessions are staggered throughout the week and limited to one class per day, there is no overlap between groups. This scheduling approach significantly reduces peak traffic volume and prevents congestion during arrival and departure times.

### **Parking and Transportation**

Students and staff will park in the designated parking area of the building, in full compliance with local zoning and parking regulations.

Additionally, the program primarily serves individuals pursuing entry-level healthcare training, many of whom rely on public transportation (including buses, Metra Train, Taxi, Uber, Car Pooling) as their primary means of travel. This further reduces the demand for onsite parking.

Visitor parking will be located at the front (north side) of the building. Students, staff, and instructors will utilize the designated parking area at the rear (east side) of the building.

This separation of parking areas helps maintain an organized traffic flow, minimizes congestion, and ensures efficient use of available parking spaces.

Overall, the combination of small class sizes, staggered scheduling, limited hours of operation, and reliance on public transportation ensures that the proposed use will not create a significant burden on surrounding traffic patterns or parking resources.

9. The proposed conditional use does not result in the destruction, loss, or damage of a natural, scenic, or historic feature of major importance; and

The proposed use does not involve construction, site disturbance, or exterior alterations. All activities occur within the existing structure. No natural, scenic, or historic features will be impacted.

10. The proposed conditional use complies with all additional regulations in this title specific to the conditional use requested

The applicant shall comply with all applicable provisions of the City of Des Plaines Zoning Ordinance and any conditions imposed as part of the Conditional Use Permit. The program will also comply with all applicable state and federal regulations. Required permits and inspections will be obtained prior to commencement of operations.

Sincerely,

Wilsa dela Cruz Cabrera

Central Scholar Academy

[REDACTED]

[REDACTED]



April 15, 2026

Mayor Goczkowski and Des Plaines City Council  
CITY OF DES PLAINES

**Subject:** Planning and Zoning Board – 1585 Ellinwood Street, Case #26-009-CU

**RE:** Consideration of a Conditional Use for a Commercial School

Honorable Mayor and Members of the Des Plaines City Council:

The Planning and Zoning Board (PZB) held a public hearing on April 14, 2026 to consider the request.

1. Wilsa Dela Cruz Cabrera, representing the petitioner, provided a detailed presentation of the conditional use request and the proposed commercial school use. She described this is a low-impact vocational and educational use with five weeks of in-person instruction for four hours each week. Ms. Cabrera noted that the commercial school will be open Wednesday through Sunday for skill evaluations and Monday through Tuesday by appointment only. She described that out of the 120 hours required for students to become certified, only 40 of the instruction hours will be held on the subject property in groups of 8-10 students and one instructor. She noted that only one course will be held at a given time minimizing traffic and parking needs for the commercial school use. Ms. Cabrera showed pictures of the tenant space interior identifying the use of each space, the total number of individuals that would be in each space at a given time, and that no interior and exterior remodeling will take place on site. Finally, she identified how the proposed commercial school meets all of the conditional use standards.
2. PZB members asked if the petitioner is moving from another location; how long it takes to become a nurse; if the petitioner's organization helps with job placement; what is the hourly rate for a certified nursing assistant (CNA); if they are providing full educational training; if additional training is required after this program; if their organization is for-profit; if they are planning to grow in the future at this location; if they are able to hold one class in-person and one class online at the same time; what the cost of the program is for each student; if the final exam is administered by the State of Illinois; if they have other locations; if there are proposed changes to the interior or exterior of the space; if they knew how long the subject tenant space has been vacant; what the qualifications are for instructors; if the ten enrolled students start and end the program at the same time; how many students they will have total in a year and if they intend to surpass this amount in the future; if the elevator and sign items brought up in the staff report are the responsibility of the petitioner to address; and if the petitioner is a tenant of the building.

Ms. Cabrera responded that this a new organization so there is no existing location; that the program is 120 hours spread across five weeks; that they work with agencies that help with job placement for students after they complete the program; that the current CNA makes \$15 per hour; that a student has to be certified first before they complete their hours at the proposed commercial school and take their exam; that there is typically no additional training or further education for these students unless the future employer requires it; that their organization is for-profit; that they would be interested in growing at this location in the future although a majority of the training takes place online; that they are heavily regulated by the State of Illinois so there are limits on the number of instructors and students allowed; that they currently can only hold one session at a time; that the full cost per student is \$1,800; that the final exam is

administered by the State of Illinois; that they do have long-term care facilities that they partner for training opportunities but currently do not have a location for their organization; that no interior or exterior modifications will be made to the space; that they do not know how long the tenant space has been empty; that instructors must have a masters in nursing and a certification with the State of Illinois; that the student progression through the course depends on the specific schedule for each student; and that total number of students per year depends on enrollment numbers but they would project a maximum enrollment of 100 students initially and expand this number in the future as space allows. City staff confirmed that the outstanding items to address on the subject property are directed to the property owner to be addressed and that the petitioner is one of multiple tenants in the existing building.

3. CED staff summarized the staff report with slides providing an analysis of the request and the proposed commercial school use. Staff acknowledged the floor plan of the proposed use identifying the use of each space. Staff noted that there were no recommended conditions of approval and the motion before the PZB.
4. A member of the public stated that she thought this was a good use for this location but asked if the petitioner has received the proper approvals from the State of Illinois. Ms. Cabrera confirmed that they have not received approvals from the State of Illinois yet but it is in progress of obtaining it.
5. The PZB voted 5-0 to recommend that City Council approve the conditional use request without any conditions.

Respectfully submitted,



Joseph Catalano,  
Des Plaines Planning and Zoning Board, Vice Chairman  
Cc: City Officials/Aldermen

2. **Address:** 1585 Ellinwood Street

**Case Number:** 26-009-CU

The petitioner requests a conditional use to allow a commercial school to operate in the C-5 Central Business district at 1585 Ellinwood Street and any other variations, waivers, and zoning relief as may be necessary.

**Petitioner:** Wilsa dela Cruz Cabrera, 1585 Ellinwood Street, Suite 106, Des Plaines, IL 60016

**Owner:** DZ 1585 LLC (Representative: Lucas Fuksa, 102 Main Street, Suite 200, Park Ridge, IL 60068)

Acting Chairman Catalano opened the public hearing and swore-in Wilsa dela Cruz Cabrera, who represented the petitioner, Central Scholar Academy.

Ms. Dela Cruz Cabrera provided a detailed presentation of the conditional use request and the proposed commercial school use. She described this is a low-impact vocational and educational use with five weeks of in-person instruction for four hours each week. Ms. Cabrera noted that the commercial school will be open Wednesday through Sunday for skill evaluations and Monday through Tuesday by appointment only. She described that out of the 120 hours required for students to become certified, only 40 of the instruction hours will be held on the subject property in groups of 8-10 students and one instructor. She noted that only one course will be held at a given time minimizing traffic and parking needs for the commercial school use. Ms. Cabrera showed pictures of the tenant space interior identifying the use of each space, the total number of individuals that would be in each space at a given time, and that no interior and exterior remodeling will take place on site. Finally, she identified how the proposed commercial school meets all of the conditional use standards.

Acting Chair Catalano asked for any PZB questions.

Member Fowler asked if the petitioner is moving from another location. Ms. Dela Cruz Cabrera stated this is a new school created in January 2026 and the first location.

Member Fowler asked how long to be a certified nurse. Ms. Dela Cruz Cabrera stated it takes about 5 weeks to earn a certificate.

Member Fowler asked if the petitioner assists from job placement. Ms. Dela Cruz Cabrera stated they do work with organizations that assist students with job placement.

Acting Chair Catalano asked about the hourly pay rate for CNAs. Ms. dela Cruz Cabrera stated pay is about \$15/hr.

(There was an extended period of general discussion between the Petitioner and certain PZB members regarding the State of IL licensing process, their business expansion possibilities, student job prospects, and general professional life cycle for CNAs).

Member Weaver asked if they wish to expand if more people need to use the subject property and if the subject property be sufficient in the future. Ms. Dela Cruz Cabrera stated they would look to expand at this location in the future.

Member Veremis asked about any proposed exterior or interior improvements to the building. Ms. Dela Cruz Carera responded that no building improvements were proposed.

Member Weaver asked how many students the petitioner could enroll in a given year and how many may come to the subject property for training versus remote training. Ms. dela Cruz Cabrera stated they will have about 100 students over a given year and about 16 students at a given certificate training cycle.

Acting Chairman Catalano asked for public comment and swore in Shidi Alex. Ms. Alex states that she supports this proposal and asked if the State of IL had approved the proposed business yet. Ms. Dela Cruz Carera stated they are in review with the State of Illinois.

Acting Chairman Catalano asked for the staff report. Senior Planner Jonathan Stytz presented the staff analysis.

**Issue:** The petitioner requests a conditional use for a Commercial School in the C-5 Central Business district at 1585 Ellinwood Street, Suite 106.

**Petitioner:** Central Scholar Academy (Representative: Wilsa Dela Cruz Cabrera, 1585 Ellinwood Street, Suite 106, Des Plaines, IL 60016)

**Owner:** DZ 1585 LLC (Representative: Lucas Fuksa, 102 Main Street, Suite 200, Park Ridge, IL 60068)

**Case Number:** #26-009-CU

**PINs:** 09-17-421-033-0000 and 09-17-421-028-0000

**Ward Number:** #2, Alderman Colt Moylan

**Existing Zoning:** C-5, Central Business

**Existing Land Use:** Multi-Tenant Commercial Building with Off-Street Parking Area

**Surrounding Zoning:** North: C-5, Central Business District  
South: C-5, Central Business District  
East: C-5, Central Business District  
West: C-5, Central Business District

**Surrounding Land Uses:** North: Religious Institution (commercial)  
South: Senior Living Facility (commercial)  
East: Senior Living Facility (commercial)  
West: Vacant building (former restaurant)

**Street Classification:** Ellinwood Street is classified as a *local road* under City of Des Plaines jurisdiction.

**Comprehensive Plan:** The Comprehensive Plan designates this site as *Higher Density Urban Mix with Residential*.

**Property/Zoning History:** The subject property was annexed into the City in 1870 as a single family residence<sup>4</sup>. Around 1972, the subject property was redeveloped with a commercial building. Today, the subject property consists of an off-street parking area and multi-tenant office building, which consists of predominantly office uses with a single retail establishment also operating on site. Based on City records, there are existing items to address related to elevator inspections and an expired sign permit, which both must be addressed to comply with all current regulations.

### CONDITIONAL USE

**Request Description:**

*Overview*

The petitioner requests a conditional use to operate a commercial school as described in the attached Project Narrative. A commercial school, as defined below, is a conditional use in the C-5 district.

**COMMERCIAL SCHOOL:** An establishment, the principal use or purpose of which is teaching the skills needed to perform a particular professional job or trade including, but not limited to, schools of construction or building trade, cosmetology, cooking, motor vehicle repair, computer training facilities, vocational schools, administrative business training facilities and similar fields. "Commercial schools" do not include any use otherwise listed specifically in a zoning district as a permitted or conditional use. (Section 12-13-3 of the Zoning Ordinance).

The subject property is currently a two-story, approximately 5,000-square-foot multi-tenant office building and off-street parking area in the rear as illustrated on the attached ALTA/ACSM Land Title Survey. The commercial school would occupy the far eastern tenant space on the first level of the building without any proposed exterior and interior changes to the building itself.

*Proposed Operations*

Based on the attached Project Narrative, this use would provide a supervised skills performance evaluation on site for up to 20 hours as part of an educational healthcare training program to prepare

---

<sup>4</sup> <https://www.historicaerials.com/location/41.625/-87.875/T1890/16>. Retrieved April 7, 2026.

students to become Certified Nursing Assistants (CNAs) in the State of Illinois. This use is anticipated to operate Wednesday through Sunday from 4:00 P.M. to 8:00 P.M. for the supervised performance skills evaluation and Monday and Tuesday only by appointment as specified in the attached Project Narrative. Each course will not exceed 12 students and one instructor minimizing daily traffic and parking needs during the week. See the attached Project Narrative and attached Program Schedule for additional information.

*Floor Plans*

The existing tenant space where the commercial school use is proposed is approximately 628 square feet in area consisting of a classroom, two simulation rooms, a reception area, break room, and equipment/storage space as illustrated in the attached Floor Plan. The table below has been provided by the petitioner to illustrate the area, use, and occupancy of all rooms within the tenant space. Please see the attached Program Schedule for additional information.

| <b>Proposed Floor Plan Spaces</b> |                               |                  |                       |
|-----------------------------------|-------------------------------|------------------|-----------------------|
| <b>Space ID</b>                   | <b>Use</b>                    | <b>Area (SF)</b> | <b>Occupancy Load</b> |
| Classroom                         | Educational Classes           | 163.61 SF        | 8 persons             |
| Simulation Room #1                | Skills Performance Evaluation | 103.28 SF        | 2 persons             |
| Simulation Room #2                | Skills Performance Evaluation | 111.17 SF        | 2 persons             |
| Equipment Storage                 | Storage                       | 90.25 SF         | 1 person              |
| Reception and Library             | Business / Reception          | 105.25 SF        | 3 persons             |
| Break Room                        | Accessory / Staff Break Room  | 54.65 SF         | 1 person              |
| <b>Totals</b>                     |                               | <b>628.21 SF</b> | <b>17 persons</b>     |

*Access and Circulation*

The rear surface parking lot on the subject property is currently only accessed via a permanent and perpetual vehicle ingress and egress easement through a portion of the Brookfield Senior Living property at 800 S. Des Plaines River Road off Ellinwood Street. This easement is located just east of the subject property as illustrated in the attached ALTA/ACSM Land Title Survey and is not subject to change with this request. The proposed commercial school will have limited classes throughout the week with no more than one class at the same time and no more than ten students in each class. As a

result, there is no concern from staff that the existing off-street parking area and access drive will suffice for access and circulation.

*Off-Street Parking*

The subject property contains 25 off-street parking spaces including one accessible space. As noted in the definition above, multi-tenant office buildings are required to adhere to the minimum off-street parking space requirement for offices as identified in Section 12-9-7 of the Zoning Ordinance. Offices require a minimum of one off-street parking space for every 250 square feet of gross floor area. Based on the floor area definition, a minimum of two off-street parking spaces including one accessible space are required for Suite 106, which is satisfied by the existing parking on the subject property. Further, the petitioner notes in the attached Project Narrative that limited courses will be provided during the week and all other visitors will access the site on an appointment-only basis minimizing the overall traffic generated from this use.

It is important to note that based on the floor plans provided, approximately 9,180 square feet for the entire multi-tenant office building is factored into the parking calculation resulting in a total of 37 required off-street parking spaces for the subject property. However, pursuant to Section 12-9-2 of the Zoning Ordinance, no additional parking is required since the use of the building as a multi-tenant office building will not change with the proposed conditional use.

**Standards for Conditional Use:** Conditional Use requests are subject to the standards set forth in Section 12-3-4(E) of the Zoning Ordinance. Rationale for how the conditional use would satisfy the standards is provided below and in the attached Petitioner Responses to Standards. For its rationale, the Board may use the responses provided as written, modify them, or adopt its own.

**4. The proposed Conditional Use is in fact a Conditional Use established within the specific Zoning district involved:**

*Comment:* A commercial school is listed as a conditional use as specified in Section 12-7-3.K of the Zoning Ordinance for properties in the C-5 District.

**5. The proposed Conditional Use is in accordance with the objectives of the City's Comprehensive Plan:**

*Comment:* The Future Land Use Map of the 2019 Comprehensive Plan designates this property as *Higher Density Urban Mix with Residential*, which focuses on denser mix of commercial and residential developments. The existing multi-tenant office building does provide a denser commercial component but does not provide any residential component at this time. While the conditional use request adds to the existing commercial uses on site, it does not fully align with the Future Land Use classification noted on the Comprehensive Plan.

**6. The proposed Conditional Use is designed, constructed, operated and maintained to be harmonious and appropriate in appearance with the existing or intended character of the general vicinity:**

*Comment:* The proposed commercial school use will be located within an established concrete and brick office building that is generally harmonious and appropriate in appearance to surrounding commercial and office development in the immediate area. The street frontage and improvements match those along the remainder of Ellinwood Street, including landscape planter boxes.

**5. The proposed Conditional Use is not hazardous or disturbing to existing neighboring uses:**

*Comment:* The proposed commercial school use will be conducted entirely within the individual tenant space inside the building itself minimizing perceived adverse effects. In addition, the existing parking and drive aisle areas will remain to accommodate both student and teacher access to the site to minimize adverse effects on neighboring uses.

**7. The proposed Conditional Use is to be served adequately by essential public facilities and services, such as highways, streets, police and fire protection, drainage structures, refuse disposal, water and sewer, and schools; or, agencies responsible for establishing the Conditional Use shall provide adequately any such services:**

*Comment:* The subject property is adequately served by essential public facilities and services, which will not change with the operation of the commercial school on site. Staff do not have concerns that this use will impact the essential public facilities and services currently serving the subject property.

**8. The proposed Conditional Use does not create excessive additional requirements at public expense for public facilities and services and will not be detrimental to the economic well-being of the entire community:**

*Comment:* The existing multi-tenant office building on the subject property currently provide services that benefit the community as a whole. A commercial school provides additional services that further benefit the community without excessive additional requirements for public facilities and services.

**11. The proposed Conditional Use does not involve uses, activities, processes, materials, equipment and conditions of operation that will be detrimental to any persons, property, or the general welfare by reason of excessive production of traffic, noise, smoke fumes, glare or odors:**

*Comment:* The specific educational and evaluation activities listed for the proposed commercial school does not appear to create any adverse effects in respect to traffic, noise, smoke fumes, glare, and odors. All activities of the proposed commercial school use will occur inside the individual tenant space and will only occur for a portion of each day, minimizing adverse effects on surrounding properties.

**12. The proposed Conditional Use provides vehicular access to the property designed so that it does not create an interference with traffic on surrounding public thoroughfares:**

*Comment:* The vehicular access to the subject property will occur on private property accessible by utilizing the existing street connection, is sufficient for the commercial school, and will not be adjusted. The location and layout of the rear off-street parking lot for the multi-tenant office building is near one of the multiple entrances to the building and would not interfere with surrounding public thoroughfares.

**13. The proposed Conditional Use does not result in the destruction, loss, or damage of natural, scenic, or historic features of major importance:**

*Comment:* The subject property has already been developed with the multi-tenant office building and off-street parking area. The commercial school will occupy a portion of the existing building without further development or any new loss of these features.

**14. The proposed Conditional Use complies with all additional regulations in the Zoning Ordinance specific to the Conditional Use requested:**

*Comment:* The proposed commercial school will comply with all other requirements of the Zoning Ordinance for the C-5 Central Business District.

**PZB Procedure and Recommended Conditions:** Under Section 12-3-4.D (Procedure for Review and Decision for Conditional Uses) of the Zoning Ordinance, the PZB has the authority to *recommend* that the City Council approve or deny requested commercial school use. Consideration of the request should be based on a review of the information presented by the applicant and the findings made above, as specified in Section 12-3-4.E (Standards for Conditional Use) of the Zoning Ordinance. There are no staff recommended conditions of approval for this request.

Acting Chairman Catalano asked for PZB comments or questions.

Member Veremis asked if the subject property maintenance comments are the petitioner's or the property owner's responsibility. Senior Planner Stytz stated it is not the Petitioner's responsibility.

Member Weaver is the petitioner a tenant or property owner. Senior Planner Stytz confirmed the Petitioner is a tenant.

Member Fowler moved and Member Veremis seconded a motion to recommend the City Council approve the proposed Conditional Use as requested without any conditions.

AYES: Weaver, Veremis, Fowler, Zadrozny and Catalano  
NAYS: None  
ABSTAIN: None

\*\*\*MOTION CARRIED\*\*\*

**CITY OF DES PLAINES**

**ORDINANCE Z - 9 - 26**

**AN ORDINANCE APPROVING A CONDITIONAL USE PERMIT TO OPERATE A COMMERCIAL SCHOOL AT 1585 ELLINWOOD STREET, SUITE 106, DES PLAINES, ILLINOIS.**

**WHEREAS**, DZ 1585 LLC ("**Owner**") is the owner of the property commonly known as 1585 Ellinwood Street, Suite 106, Des Plaines, Illinois ("**Subject Property**"); and

**WHEREAS**, the Subject Property is located in the C-5 Central Business District of the City ("**C-5 District**") and improved with a multi-tenant building ("**Building**") and an off-street parking area; and

**WHEREAS**, Central Scholar Academy LLC, an Illinois corporation ("**Petitioner**"), desires to operate a commercial school designed for training students to become Certified Nursing Assistance within the State of Illinois, within the far eastern tenant space on the first level of the Building ("**Commercial School**"); and

**WHEREAS**, the "Des Plaines Zoning Ordinance of 1998," as amended ("**Zoning Ordinance**"), is codified as Title 12 of the City Code of the City of Des Plaines ("**City Code**"); and

**WHEREAS**, pursuant to 12-7-3.K of the Zoning Ordinance, the operation of the Commercial School is permitted in the C-5 District only with a conditional use permit approved by the City Council; and

**WHEREAS**, pursuant to Section 12-3-4 of the Zoning Ordinance, Petitioner filed, with the consent of the Owner, an application with the City for the approval of a conditional use permit to allow the operation of the Commercial School on the Subject Property ("**Conditional Use Permit**"); and

**WHEREAS**, within 15 days after the receipt thereof, the Petitioner's application was referred by the Department of Community and Economic Development to the Planning and Zoning Board of the City of Des Plaines ("**PZB**"); and

**WHEREAS**, within 90 days from the date of the Petitioner's application a public hearing was held by the PZB on April 14, 2026, pursuant to notice published in the *Des Plaines Journal* on March 25, 2026; and

**WHEREAS**, notice of the public hearing was mailed to all property owners within 500 feet of the Subject Property; and

**WHEREAS**, during the public hearing, the PZB heard testimony and received evidence with respect to how the Petitioner intended to satisfy and comply with the applicable provisions of the Zoning Ordinance; and

**WHEREAS**, pursuant to Section 12-3-4 of the Zoning Ordinance, the PZB filed a written report with the City Council on April 15, 2026, summarizing the testimony and evidence received by the PZB and stating the Board's recommendation, by a vote of 5-0, to approve the Conditional Use Permit, subject to certain terms and conditions; and

**WHEREAS**, the Petitioner made representations to the PZB with respect to the Conditional Use Permit which representations are hereby found by the City Council to be material and upon which the City Council relies in approving the Conditional Use Permit; and

**WHEREAS**, the City Council has considered the written report of the PZB, the applicable standards for conditional use permits set forth in the Zoning Ordinance, and the Community and Economic Development Staff Memorandum dated April 23, 2026, and has determined that it is in the best interest of the City and the public to approve the Conditional Use Permit in accordance with the provisions of this Ordinance;

**NOW, THEREFORE, BE IT ORDAINED** by the City Council of the City of Des Plaines, Cook County, Illinois, in the exercise of its home rule powers, as follows:

**SECTION 1. RECITALS.** The recitals set forth above are incorporated herein by reference and made a part hereof, the same constituting the factual basis for this Ordinance.

**SECTION 2. LEGAL DESCRIPTION OF SUBJECT PROPERTY.** The Subject Property is legally described as follows:

A tenant space designated as Suite 106 within the following described Property:

PARCEL 1:

THE NORTHWESTERLY 150.0 FEET OF LOTS 103 AND 104 IN THE TOWN OF RAND (NOW THE CITY OF DES PLAINES), BEING A SUBDIVISION OF PART OF SECTIONS 16, 17, 20 AND 21, TOWNSHIP 41 NORTH, RANGE 12, EAST OF THE THIRD PRINCIPAL MERIDIAN, IN COOK COUNTY, ILLINOIS.

PARCEL 2:

PERMANENT AND PERPETUAL EASEMENT FOR THE BENEFIT OF PARCEL 1, AS DISCLOSED BY DEED FROM CITY OF DES PLAINES TO RIVER OAKS PARTNERS DATED JUNE 2, 1992 AND RECORDED JUNE 5, 1992 AS DOCUMENT 92396888 AND CREATED BY DEED FROM GARFIELD RIDGE

TRUST AND SAVINGS BANK, AS TRUSTEE UNDER TRUST NUMBER 89813 TO RICHARD E. VAN STOCKUM AND KRISTINA M. VAN STOCKUM, AS TO AN UNDIVIDED 1/2 INTEREST AND RANGVALD T. THOMPSON, AS TO AN UNDIVIDED 1/2 INTEREST DATED JUNE 24, 1993 AND RECORDED JUNE 24, 1993 AS DOCUMENT 93482922, FOR THE PURPOSE OF VEHICULAR INGRESS AND EGRESS OVER THE FOLLOWING DESCRIBED PROPERTY:

THE WEST 25.0 FEET OF THE NORTH 105.0 OF LOT 105 IN TOWN OF RAND, A SUBDIVISION OF THE SOUTH 1/2 OF THE SOUTHWEST 1/4 OF SECTION 16, PART OF THE EAST 1/2 OF THE SOUTHEAST 1/4 OF SECTION 17, THE NORTHEAST 1/4 OF SECTION 20, THE NORTHWEST 1/4 OF SECTION 21, ALL IN TOWNSHIP 41 NORTH, RANGE 12, EAST OF THE THIRD PRINCIPAL MERIDIAN, IN COOK COUNTY, ILLINOIS .

PINs: 09-17-421-033-0000 and 09-17-421-028-0000

Commonly known as 1585 Ellinwood Street, Suite 106, Des Plaines, Illinois.

**SECTION 3. APPROVAL OF CONDITIONAL USE PERMIT.** Subject to and contingent upon the conditions, restrictions, limitations and provisions set forth in Section 4 of this Ordinance, the City Council hereby grants the Petitioner the Conditional Use Permit to allow the operation of the Commercial School on the Subject Property in the C-5 District. The Conditional Use Permit granted by this Ordinance is consistent with and equivalent to a "special use" as referenced in Section 11-13-25 of the Illinois Municipal Code, 65 ILCS 5/11-13-25.

**SECTION 4. CONDITIONS.** The Conditional Use Permit granted in Section 3 of this Ordinance shall be, and is hereby, expressly subject to and contingent upon the following conditions, restrictions, limitations, and provisions:

A. **Compliance with Law and Regulations.** The development, use, operation, and maintenance of the Subject Property and the Commercial School by the Petitioner must comply with all applicable City codes and ordinances, as the same have been or may be amended from time to time, except to the extent specifically provided otherwise in this Ordinance.

B. Compliance with Plans. Except for minor changes and site work approved by the City Director of Community and Economic Development or Director of Public Works and Engineering (for matters within their respective permitting authorities) in accordance with all applicable City standards, the development, use, operation, and maintenance of the Subject Property and the Commercial School by the Petitioner must comply with the following plans and documents:

1. The Project Narrative, prepared by the Petitioner, consisting of 10 pages, with a latest revision date of April 1, 2026, a copy of which is attached to and made a part of this Ordinance as *Exhibit A*;

2. The Program Schedule, prepared by the Petitioner, consisting of three pages, with a latest revision date of April 1, 2026, a copy of which is attached to and made a part of this Ordinance as *Exhibit B*; and

3. The Floor Plan, prepared by Petitioner, consisting of one page, and with a latest revision date of April 1, 2026, a copy of which is attached to and made a part of this Ordinance as *Exhibit C*.

C. Regulatory Compliance. The Owner or Petitioner must address outstanding noncompliant conditions related to elevator inspections and renew the sign permit for the Subject Property to bring the Subject Property into full compliance with all current City regulations prior to the issuance of a certificate of occupancy.

D. Operational Standards. The Commercial School will operate Wednesday through Sunday from 4:00 P.M. to 8:00 P.M. for the supervised performance skills evaluation and Monday and Tuesday only by appointment as specified. Each course will not exceed 12 students and one instructor minimizing daily traffic and parking needs during the week.

E. Parking and Access. All student and staff parking must be contained within the designated off-street parking areas for the Subject Property to ensure no adverse impact on surrounding properties. All vehicular access must utilize the existing private ingress and egress easement through 800 S. Des Plaines River Road.

**SECTION 5. FAILURE TO COMPLY WITH CONDITIONS.**

A. Any person, firm or corporation who violates, disobeys, omits, neglects or refuses to comply with, or resists the enforcement of, any of the provisions of this Ordinance shall be fined not less than \$75.00 or more than \$750.00 for each offense. Each and every day that a violation of this Ordinance is allowed to remain in effect shall constitute a complete and separate offense. In addition, the appropriate authorities of the City may take such other action as they deem proper to enforce the terms and conditions of this Ordinance, including, without limitation, an action in equity to compel compliance with its terms. Any person, firm or corporation violating the terms of this Ordinance shall be subject, in addition to the foregoing penalties, to the payment of court costs and reasonable attorneys' fees.

B. In the event that the Petitioner fails to develop or maintain the Subject Property in accordance with the requirements of the Zoning Ordinance, or the conditions set forth in Section 4 of this Ordinance, the Conditional Use Permit granted in Section 3 of this Ordinance may be revoked after notice and hearing before the Zoning Administrator of the City, all in accordance with the procedures set forth in Section 12-4-7 of the Zoning Ordinance. In the event of revocation, the development and use of the Subject Property will be governed solely by the regulations of the C-5 District. Further, in the event of such revocation of the Conditional Use Permit, the City Manager and City's General Counsel are hereby authorized and directed to bring such zoning enforcement action as may be appropriate under the circumstances. The Petitioner acknowledges

that public notices and hearings have been held with respect to the adoption of this Ordinance, has considered the possibility of the revocation provided for in this Section, and agrees not to challenge any such revocation on the grounds of any procedural infirmity or any denial of any procedural right, provided that the notice and hearing required by Section 12-4-7 of the Zoning Ordinance is provided to the Petitioner.

**SECTION 6. BINDING EFFECT.** This Ordinance and the privileges, obligations, and provisions contained in this Ordinance run with the Subject Property and inure to the benefit of, and are binding upon, the Owner and the Applicant, and their respective personal representatives, successors, and assigns, including, without limitation, subsequent purchasers or lessees of the Property.

**SECTION 7. SEVERABILITY.** If any paragraph, section, clause or provision of this Ordinance is held invalid, the remainder shall continue in full force and effect without affecting the validity of the remaining portions of the Ordinance.

**SECTION 8. EFFECTIVE DATE.** This Ordinance shall be in full force and effect from and after the occurrence of the following:

- A. its passage, approval and publication in pamphlet form as provided by law;
- B. the filing with the City Clerk by the Petitioner and the Owner, not less than 60 days after the passage and approval of this Ordinance, of an unconditional agreement and consent to accept and abide by each and all of the terms, conditions, and limitations set forth in this Ordinance. Said unconditional agreement and consent shall be in substantially the form attached to, and by this reference made a part of, this Ordinance as *Exhibit D*;

C. at the Petitioner’s sole cost and expense, the recordation of this Ordinance together with such exhibits as the City Clerk deems appropriate, with the Office of the Cook County Recorder; and

D. in the event that the Petitioner or the Owner does not file with the City Clerk a fully executed copy of the unconditional agreement and consent referenced in Section 8.B of this Ordinance, within 60 days after the date of passage of this Ordinance by the City Council, the City Council shall have the right, in its sole discretion, to declare this Ordinance null and void and of no force or effect.

**PASSED** this \_\_\_\_\_ day of \_\_\_\_\_, 2026.

**APPROVED** this \_\_\_\_\_ day of \_\_\_\_\_, 2026.

**VOTE:** AYES \_\_\_\_\_ NAYS \_\_\_\_\_ ABSENT \_\_\_\_\_

\_\_\_\_\_  
**MAYOR**

**ATTEST:**

\_\_\_\_\_  
**CITY CLERK**

Published in pamphlet form this \_\_\_\_\_ day of \_\_\_\_\_, 2026.

Approved as to form:

\_\_\_\_\_  
**CITY CLERK**

\_\_\_\_\_  
**Peter M. Friedman, General Counsel**



# Central Scholar Academy

1585 Ellinwood St. Suite 106 Des Plaines, IL 60016

██████████

## CONDITIONAL USE APPLICATION

### Commercial School

Central Scholar Academy. LLC

### Property Address:

1585 Ellinwood Street

Des Plaines, Illinois

### Applicant:

Wilsa dela Cruz Cabrera

### Property Owner:

Lucas Fuksa

### PIN (if available):

09-17-421-033-0000

### Date of Submittal/ Revision:

4/1/2026



# Central Scholar Academy

1585 Ellinwood St. Suite 106 Des Plaines, IL 60016

[REDACTED]

## CONDITIONAL USE OF PROPERTY APPLICATION

### Basic Nursing Assistant Training Program (BNATP)

#### I. Purpose of the Request

Central Scholar Academy respectfully submits this application for a Conditional Use Permit to operate a Basic Nursing Assistant Training Program (BNATP) at the above-referenced property in Des Plaines, Illinois.

The proposed onsite use consists of supervised skills performance evaluation at proposed location in Des Plaines totaling 20 hours, delivered over approximately four (4) hours per week, as part of an educational healthcare training program that prepares students to become Certified Nursing Assistants (CNAs) in the State of Illinois. The program will operate in compliance with requirements established by the Illinois Department of Public Health.

The Academy seeks conditional approval to operate as an educational/vocational training facility within the applicable zoning district. This on-campus component is scheduled over 5-week periods and averages approximately 4 hours per week, with no daily or full-day instructional use of space. The enrollment and class size are highly regulated by the Illinois Department of Public Health, including a 12:1 student-to-instructor ratio requirement. As a result, no more than 12 students are allowed to attend each supervised skills evaluation session/class.



# Central Scholar Academy

1585 Ellinwood St. Suite 106 Des Plaines, IL 60016

██████████

## II. Description of the Proposed Use

The BNATP is a structured healthcare education program that provides:

- 60 Hours - Virtual Classroom instruction (didactic/theory) - (Not at the campus)
- 20 Hours - Supervised Performance Skills Evaluation (On-campus- Des Plaines)
- 40 Hours - Clinical experience at an approved healthcare facility (off-site)

## Program Structure

- Minimum of 120 instructional hours in accordance with Illinois regulations
- Supervised Performance Skills Evaluation at proposed location in Des Plaines is limited to 4 hours per week.
- Off-site clinical rotations at IDPH-approved long-term care facilities
- Small class sizes to ensure compliance with IDPH instructor to student ratio.

## III. Hours of Operation

Proposed hours of operation:

- Monday – by appointment
- Tuesday - by appointment
- Wednesday – Supervised Performance Skills Evaluation 4:00 PM – 8:00 PM
- Thursday– Supervised Performance Skills Evaluation 4:00 PM – 8:00 PM
- Friday – Supervised Performance Skills Evaluation 4:00 PM – 8:00 PM



# Central Scholar Academy

1585 Ellinwood St. Suite 106 Des Plaines, IL 60016

██████████

- Saturday – Supervised Performance Skills Evaluation 8:00 AM- 12:00 PM
- Sunday – Supervised Performance Skills Evaluation 8:00 AM- 12:00 PM

Supervised Performance Skills Evaluation sessions are held Wednesday through Sunday.

Administrative office hours are available in person by appointment only.

- Due to simulation room capacity limitations, Supervised Performance Skills Evaluation is conducted in small groups to maintain safe occupancy levels and in compliance with Illinois Department of Public Health (IDPH).
- No overnight operations.

#### **IV. Traffic and Parking Impact**

The BNATP operates in 5-week instructional cycles. The didactic (theory) portion of the program is delivered entirely through virtual/online instruction and does not occur at the Des Plaines location. Students are only physically present at the proposed site for the required Supervised Performance Skills Evaluation component.

The Supervised Performance Skills Evaluation training at Des Plaines consists of a total of 20 hours distributed over the 5-week period, averaging approximately 4 hours per week for the entire 5 week course. Supervised Performance Skills Evaluation sessions are scheduled on a staggered basis to prevent congestion and avoid overlapping arrival and departure times.



# Central Scholar Academy

1585 Ellinwood St. Suite 106 Des Plaines, IL 60016

██████████

This structure ensures that onsite attendance is limited, controlled, and predictable, with only one small class present per session in accordance with Illinois Department of Public Health requirements.

In accordance with regulations established by the Illinois Department of Public Health (IDPH), the Basic Nursing Assistant Training Program (BNATP) maintains a strict instructor-to-student ratio of one (1) instructor to a maximum of ten (12) students during all Supervised Performance Skills Evaluation and clinical training sessions.

To ensure full compliance, each Supervised Performance Skills Evaluation session is limited to no more than 10 students per instructor or 1 class per scheduled operational time. This structure ensures appropriate supervision, enhances student safety, and supports effective hands-on skills training in a controlled learning environment.

Each cohort attends one 4-hour Supervised Performance Skills Evaluation session per week. Supervised Performance Skills Evaluation sessions in Des Plaines are scheduled Wednesday through Sunday.

Classes are distributed across different days and times throughout the 5-week period to minimize simultaneous occupancy.

This staggered scheduling ensures that no more than 12 students per session are present at one time, in accordance with Illinois Department of Public Health requirements.



# Central Scholar Academy

1585 Ellinwood St. Suite 106 Des Plaines, IL 60016

██████████

## **Anticipated Daily Visitor Traffic**

The proposed use of the site in Des Plaines will occur during off-peak hours, which further supports minimal impact on surrounding traffic patterns. Based on the program's structure and limited onsite activity, traffic is expected to remain low and well controlled.

Each session will include approximately 8 students, with a maximum of 10 students per session, in compliance with program and regulatory requirements. In addition, one instructional staff member will be present per session.

Because sessions are staggered throughout the week and limited to one class per day, there is no overlap between groups. This scheduling approach significantly reduces peak traffic volume and prevents congestion during arrival and departure times.

## **Parking and Transportation**

Students and staff will park in the designated parking area of the building, in full compliance with local zoning and parking regulations.

Additionally, the program primarily serves individuals pursuing entry-level healthcare training, many of whom rely on public transportation (including buses, Metra Train, Taxi, Uber, Car Pooling) as their primary means of travel. This further reduces the demand for onsite parking.



# Central Scholar Academy

1585 Ellinwood St. Suite 106 Des Plaines, IL 60016

██████████

Visitor parking will be located at the front (north side) of the building. Students, staff, and instructors will utilize the designated parking area at the rear (east side) of the building.

This separation of parking areas helps maintain an organized traffic flow, minimizes congestion, and ensures efficient use of available parking spaces.

Overall, the combination of small class sizes, staggered scheduling, limited hours of operation, and reliance on public transportation ensures that the proposed use will not create a significant burden on surrounding traffic patterns or parking resources.

## **V. Compatibility with Surrounding Uses**

The proposed BNATP is compatible with surrounding commercial/educational/professional uses because:

- It generates minimal noise
- There is no industrial activity
- No outdoor operations are conducted
- All instructional activities occur indoors
- Clinical training is conducted off-site

The use is educational in nature and consistent with community-serving institutional functions.

## **VI. Public Benefit**

Approval of this conditional use will:



# Central Scholar Academy

1585 Ellinwood St. Suite 106 Des Plaines, IL 60016

- Support healthcare workforce development in the Des Plaines area
- Address statewide CNA workforce shortages
- Provide local residents with career advancement opportunities
- Increase access to entry-level healthcare training
- Contribute positively to the local economy

The program directly supports regional healthcare facilities by preparing qualified nurse aides.

Students and staff will utilize designated onsite parking areas in full compliance with City zoning and parking requirements. Given the limited hours of operation and low occupancy levels, the proposed educational use is low-impact and comparable to other small-scale, office or classroom-based instructional uses permitted within the district.

## **VII. Compliance with City Ordinances**

Central Scholar Academy will:

- Comply with all City of Des Plaines zoning requirements
- Obtain all required building permits, occupancy certificates, and fire inspections
- Maintain ADA accessibility compliance
- Adhere to all applicable local, state, and federal regulations

The Academy commits to operating in a professional, safe, and community-conscious manner.

## **VIII. No Adverse Impact on Surrounding Uses**



# Central Scholar Academy

1585 Ellinwood St. Suite 106 Des Plaines, IL 60016

██████████

The school will operate indoors only, produce minimal noise, and be confined to the private areas of the school; it has no outdoor activities, no industrial equipment or hazardous materials, and does not operate late at night or overnight. As a result, the use is fully compatible with surrounding commercial, office, and professional uses.

## **IX. Conclusion**

Approval of this Conditional Use application will directly benefit local assisted living and healthcare providers, including Discovery Village, which is located approximately 350 feet from the proposed site. Establishing the Basic Nursing Assistant Training Program will meaningfully contribute to workforce development within a high-demand healthcare sector and help address the growing need for qualified nursing assistants in the community.

Central Scholar Academy has also confirmed an immediate need for CNAs with Vanguard Home Health, which operates in the same building. This partnership further underscores the direct workforce demand and community benefit that the program will serve.

The proposed use aligns with the goals of the City of Des Plaines by promoting economic vitality, expanding local employment opportunities, and strengthening essential community services.

Central Scholar Academy respectfully requests approval of a Conditional Use Permit to operate a Basic Nursing Assistant Training Program at the proposed location in Des Plaines. The proposed use:



# Central Scholar Academy

1585 Ellinwood St. Suite 106 Des Plaines, IL 60016



- Is consistent with community-serving educational purposes
- Presents minimal impact to surrounding properties
- Supports local healthcare workforce development
- Complies with all applicable local, state, and regulatory standards
- 

We appreciate the City's consideration of this request and look forward to contributing positively to the Des Plaines community.

**Submitted by:**

Wilsa dela Cruz Cabrera, BSN, RN, CMCN

President

Central Scholar Academy





# Central Scholar Academy

1585 Ellinwood St. Suite 106 Des Plaines, IL 60016



April 1, 2026

City of Des Plaines  
Community & Economic Development Department  
1420 Miner Street  
Des Plaines, IL 60016

Subject: Occupant Load and Program Schedule – Conditional Use Submission

**Dear Community & Economic Development Department,**

This letter is submitted in support of the Conditional Use Permit application for **Central Scholar Academy**, a vocational training institution located at the above address.

The facility will be utilized to provide a **Basic Nursing Assistant Training Program (BNATP)** supervised skills performance evaluation instruction only.

The program is delivered over a five-week period for each cohort, with one class session per week. Each session is four hours in duration - total of 20 hours in a span of five (5) weeks, with a minimum of eight (8) students, and a maximum of ten (10) students per class.

Due to simulation room capacity limitations, laboratory instruction is conducted in rotating small groups to maintain safe occupancy levels and ensure effective supervision.



# Central Scholar Academy

1585 Ellinwood St. Suite 106 Des Plaines, IL 60016



Occupant loads have been determined in accordance with the International Building Code (IBC),

Table 1004.5, using the following occupant load factors:

| Space               | Dimensions     | Area (SF) | Occupancy Classification                  | Factor (SF/Person) | Occupant Load |
|---------------------|----------------|-----------|---|--------------------|---------------|
| Classroom           | 12'8" × 12'11" | 163.61    | Educational (Classroom)                   | 20 net             | 8             |
| Simulation Room 1   | 8'11" × 11'7"  | 103.28    | Skills Performance Evaluation Instruction | 50 net             | 2             |
| Simulation Room 2   | 9'8" × 11'6"   | 111.17    | Skills Performance Evaluation Instruction | 50 net             | 2             |
| Equipment Storage   | 9'6" × 9'6"    | 90.25     | Storage                                   | 500 gross          | 1             |
| Reception & Library | 9'8" × 10'11"  | 105.53    | Business / Reception                      | 150 gross          | 3             |
| Break Room          | 5'1" × 10'9"   | 54.65     | Accessory / Staff Break Area              | 150 gross          | 1             |

No more than two class sessions are conducted per day, scheduled as follows:

- Monday – by appointment
- Tuesday - by appointment
- Wednesday – Supervised Performance Skills Evaluation 4:00 PM – 8:00 PM
- Thursday– Supervised Performance Skills Evaluation 4:00 PM – 8:00 PM



# Central Scholar Academy

1585 Ellinwood St. Suite 106 Des Plaines, IL 60016



- Friday – Supervised Performance Skills Evaluation 4:00 PM – 8:00 PM
- Saturday – Supervised Performance Skills Evaluation 8:00 AM- 12:00 PM
- Sunday – Supervised Performance Skills Evaluation 8:00 AM- 12:00 PM

Supervised Performance Skills Evaluation sessions are held Wednesday through Sunday.

Administrative office hours are available in person by appointment only.

Overall, the facility is designed to maintain a controlled, low-density occupancy appropriate for vocational training and to support safe operations and egress in compliance with applicable building and safety codes.

We respectfully request your review and approval of this Conditional Use Permit application. Please do not hesitate to contact us should additional information or documentation be required.

Thank you for your time and consideration.

Sincerely,

Wilsa dela Cruz Cabrera  
Central Scholar Academy



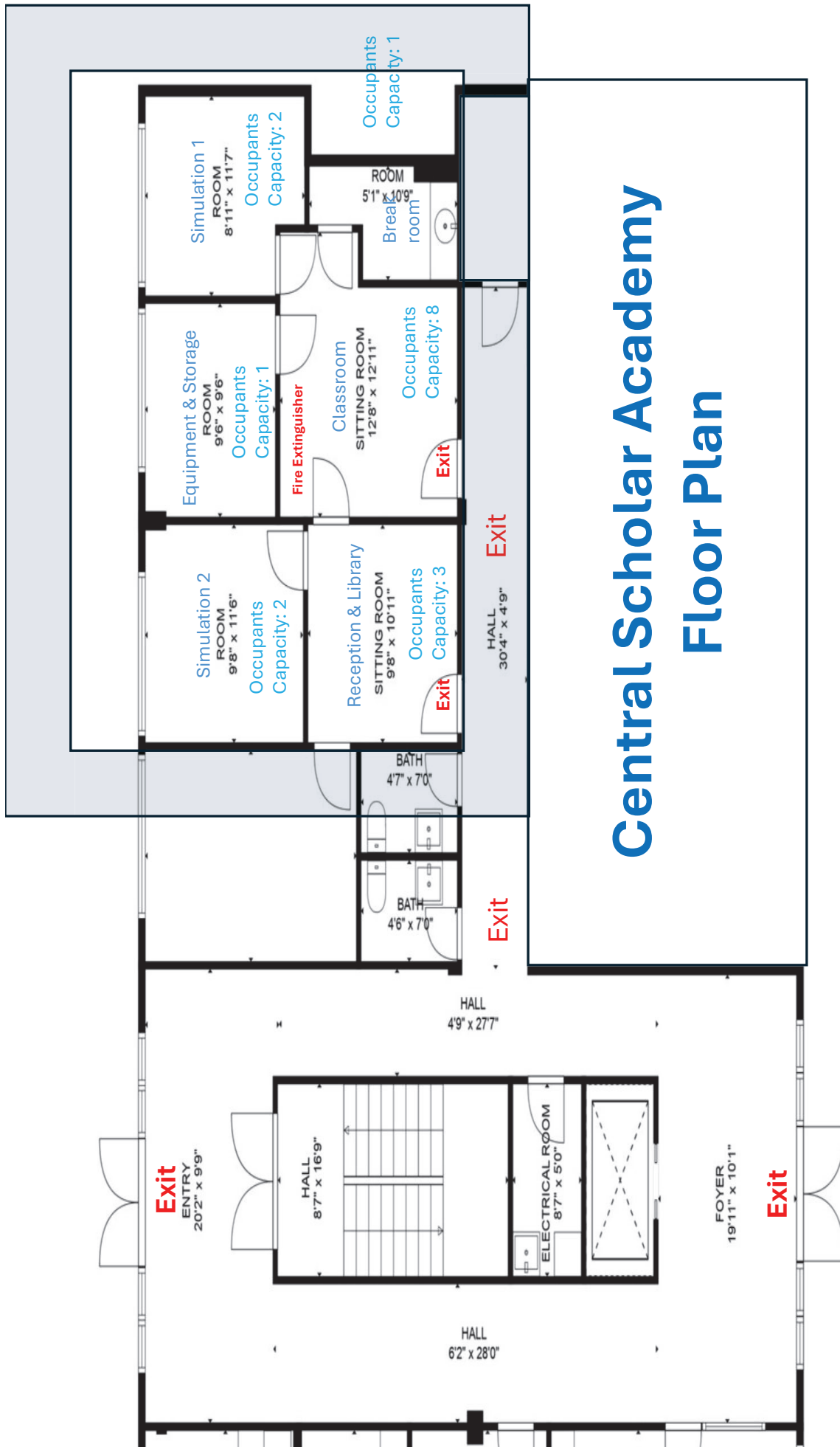

# Central Scholar Academy Floor Plan

**EXHIBIT D**

**UNCONDITIONAL AGREEMENT AND CONSENT**

**TO:** The City of Des Plaines, Illinois ("*City*");

**WHEREAS**, Ordinance No. Z-9-26 adopted by the City Council of the City of Des Plaines on \_\_\_\_\_, 2026 ("*Ordinance*"), grants approval of a conditional use permit to allow Central School Academy LLC ("*Petitioner*") to operate a commercial school use on the property commonly known as 1585 Ellinwood Street, Suite 106, Des Plaines, Illinois ("*Subject Property*"), subject to certain conditions; and

**WHEREAS**, the Subject Property is owned by DZ 1585 LLC ("*Owner*"); and

**WHEREAS**, the Petitioner and the Owner desire to evidence to the City their unconditional agreement and consent to accept and abide by each of the terms, conditions, and limitations set forth in said Ordinance, and their consent to record the Ordinance and this Unconditional Agreement and Consent against the Subject Property;

**NOW, THEREFORE**, the Petitioner and the Owner do hereby agree and covenant as follows:

1. The Petitioner and the Owner hereby unconditionally agree to accept, consent to and abide by all of the terms, conditions, restrictions, and provisions of the Ordinance.
2. The Petitioner and the Owner acknowledge and agree that the City is not and shall not be, in any way, liable for any damages or injuries that may be sustained as a result of the City's review and approval of any plans for the Subject Property, the adoption of the Ordinance, or the issuance of any permits for the use and development of the Subject Property, and that the City's review and approval of any such plans and ordinance, and issuance of any such permits does not, and shall not, in any way, be deemed to insure the Petitioner or the Owner against damage or injury of any kind and at any time.
3. The Petitioner and the Owner acknowledge that the public notices and hearings have been properly given and held with respect to the adoption of the Ordinance, have considered the possibility of the revocation provided for in the Ordinance, and agree not to challenge any such revocation on the grounds of any procedural infirmity or any denial of any procedural right, provided that the procedures required by Section 12-4-7 of the City's Zoning Ordinance are followed.
4. The Petitioner agrees to and does hereby hold harmless and indemnify the City, the City's corporate authorities, and all City elected and appointed officials, officers, employees, agents, representatives, and attorneys, from any and all claims that may, at any time, be asserted against any of such parties in connection with (a) the City's

review and approval of any plans and issuance of any permits, (b) the procedures followed in connection with or the adoption of the Ordinance, (c) the development, construction, maintenance, and use of the Subject Property, and (d) the performance by Petitioner of its obligations under this Unconditional Agreement and Consent.

- 5. The Petitioner hereby agrees to pay all expenses incurred by the City in defending itself with regard to any and all of the claims mentioned in this Unconditional Agreement and Consent. These expenses shall include all out-of-pocket expenses, such as attorneys' and experts' fees, and shall also include the reasonable value of any services rendered by any employees of the City.

ATTEST:

**CENTRAL SCHOLAR ACADEMY LLC**

By: \_\_\_\_\_

By: \_\_\_\_\_

Print Name: \_\_\_\_\_

Its: \_\_\_\_\_

ATTEST:

**DZ 1585 LLC**

By: \_\_\_\_\_

By: \_\_\_\_\_

Print Name: \_\_\_\_\_

Its: \_\_\_\_\_